

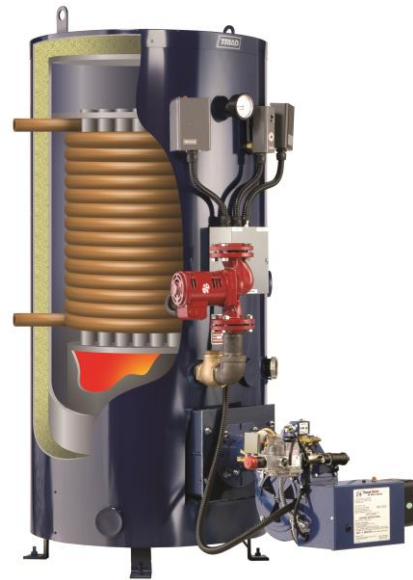

By Superior Boiler Technologies

**OPERATIONS
AND
MAINTENANCE
MANUAL**



**Hydronic Boilers
Series 300 through Series 2000
SH, LT, DHW and
Combination Models**

Superior Boiler Technologies
Hutchinson, KS 67501

Superior Boiler Technologies

!! ATTENTION !!

READ THIS MANUAL AND THE BURNER MANUAL VERY CAREFULLY!
THEY ARE BOTH VERY IMPORTANT!

DO NOT SKIP OVER THE BOILER NOTES AND WARNINGS IN SECTION I WHICH CONTAINS INFORMATION THAT MUST BE READ AND UNDERSTOOD. SUPERIOR BOILER TECHNOLOGIES IS A MANUFACTURER AND DOES NOT PROVIDE SITE SPECIFIC ENGINEERING. ALWAYS USE AN EXPERIENCED ENGINEER TO DESIGN YOUR SYSTEM.

THESE ITEMS IN PARTICULAR ARE VERY IMPORTANT:

- BOILER SAFETY
 - Read the Warnings in this manual.
- VENTING
 - Draft no more negative than -0.05" wc
- WATER TREATMENT/QUALITY (See Section I & VII for more detail)
 - pH between 8.0 and 10.0
 - Oxygen less than 250 ppb
 - Total Dissolved Solids (TDS) levels < 3000 ppm

BURNER/BOILER STARTUP MUST BE PERFORMED BY AN
AUTHORIZED TRIAD TECHNICIAN OR WARRANTY WILL BE VOIDED.

Superior Boiler Technologies
Operations And Maintenance Manual For
Hydronic Boiler Models

TABLE OF CONTENTS:

Section I	BASIC BOILER WARNINGS
Section II	HYDRONIC BOILER MODEL INFORMATION Packing Slip Wiring Diagrams
Section III	BOILER SYSTEM COMPONENTS
Section IV	GENERAL OPERATIONS
Section V	INSTALLATION & STARTUP INSTRUCTIONS
Section VI	OEM COMPONENT MANUALS
Section VII	GENERAL MAINTENANCE
Section VIII	TROUBLESHOOTING For Technical Service Only

Retain this manual and keep it readily available, typically near the boiler.

Forward:

TRIAD Boilers have a history of over 80 years of superior service. TRIAD patented the original isolated, modular boiler system concept. Each boiler / burner package has been specifically matched to provide optimal performance. The OEM (Original Equipment Manufacturer) burners, controls, and pumps are all first quality, name-brand components. The boilers, however, are only a part of the complete operating system. They can only meet their ratings if the system is properly designed and if the boilers receive proper care.

Two major things that must be focused on to achieve a successful implementation: Proper System Design and Proactive Preventive Maintenance. While the TRIAD Boiler website www.com may address some "Design" issues, a design engineer should be involved. This Operations and Maintenance Manual addresses many "Usage" issues.

It is important that the system design matches the performance of the boiler. A compatible design that addresses combustion air, correct system sizing, fuel and water supply, and breeching is crucial, and should be the responsibility of the system design engineer who must also ensure local code compliance. The boilers will meet their full potential when part of an appropriate system design.

Efficient burner operation is highly dependent on proper adjustment, adequate combustion air, and correct breeching. **Make sure you carefully read the burner Operating and Maintenance Manual.** Incorrectly dealing with these issues can result in, among other things, a loss of efficiency, higher operating costs, sooting, frequent cleaning, and high carbon monoxide (CO) output.

The successful, long-term operation of the boiler is dependent on the quality of its water. Failure to provide suitable water will result in corrosion and the build-up of scale and mud / sludge / sediment causing inefficient thermal transfer, an associated loss of efficiency, higher operating costs, and eventually lead to premature boiler failure.

Being cognizant of these issues, and taking proper steps when required, should result in many years of successful boiler operation.

Superior Boiler Technologies

3524 E. 4th Avenue
Hutchinson, KS 67501
Ph: 620-662-6693

SUPERIOR BOILER TECHNOLOGIES

Section I

BASIC BOILER WARNINGS



STOP: Do not go on without reading all of this section first.

TRIAD STRONGLY RECOMMENDS THAT THE SYSTEM DESIGN ENGINEER THOROUGHLY REVIEW THIS MANUAL AND THE BURNER MANUFACTURER'S MANUAL BEFORE INSTALLATION AND STARTUP.

ALL OPERATORS SHOULD BE FAMILIAR WITH THIS MATERIAL - THIS MANUAL SHOULD BE READ, ITS MATERIAL UNDERSTOOD, AND ITS INSTRUCTIONS FOLLOWED. THIS MANUAL SHOULD BE READILY AVAILABLE IN THE BOILER ROOM AS A REFERENCE.

ONLY TRAINED AND QUALIFIED INDIVIDUALS EXPERIENCED IN BOILER ROOM / LOCAL CODE REQUIREMENTS SHOULD BE USED TO INSTALL THE SYSTEM.



WARNING: The first and most critical step in the installation and startup procedure for any boiler system is to carefully read and understand the WARNINGS in this section



WARNING: Prior to startup it is important to verify the boiler has been sufficiently filled with water via the expansion tap or supply tap to a level above the LWCO control. This is very important for a boiler with an optional coil - do not simply fill the coil with water.



CAUTION: The second and very serious step is to review all of the material in this manual including the original equipment manufacturer's (OEM) component instruction information included

in Section VI and the respective burner manufacturer's installation and instruction manual included with the boiler or burner.



The third and very important step is to ensure that the system, and in particular the water, fuel and air supply, venting, and breeching components have been properly installed and meet local codes before placing the boiler in operation.

The fourth and ongoing step is to ensure that the system is properly maintained.

WARNING: It is important to make sure the main power switch and all power to the boiler is **OFF** prior to removing the cover of the main control box.

TRIAD Boilers can give years of dependable service with proper maintenance and by carefully following the instructions in this manual, the material covering OEM controls, and the burner. Failure to follow the directions and warnings can result in property damage or serious injury.

Independent Operation -- the boiler, controls, and attached pumps and accessories are activated by several controls and by the "Call For Heat" circuit. These can include remote sensors and controls. As a result, these components can be supplied with electricity and/or operate without warning. It is imperative that all power is removed and the control signal(s) is "locked out" before any maintenance is done on the boiler system.

NOTE: Ensure proper venting by consulting a stack engineer. Proper boiler venting is critical for operation of your boiler. The flue must be as large and probably larger than the diameter of the collar opening. Actual sized depends on total distance of flue. It is important to keep the vent pressure at a negative and it is even more important that the pressure is no more negative than -0.05" wc. For example, a negative pressure such as -0.10" wc, could cause the burner flame to be pulled up into the firetubes, effectively over firing the boiler. A properly sized barometric damper will help mitigate this.

Breeching, Fuel, and Burner Operations -- The burner manual as provided by the manufacturer contains a number of warnings concerning proper operation. Failure to follow these instructions, improper maintenance, improper or inadequate combustion air, fuel supply systems, or breeching can result in exposure to Carbon Monoxide or other hazards that can result in property damage, possible explosion, serious injury, or death.

Operating Limits -- Boilers heat water under pressure. When water is heated above its boiling point it can flash to steam if the pressure is removed. In addition, "dry firing a boiler" (applying heat to a boiler with inadequate water inside) can result in an extremely destructive and hazardous condition caused by the rapid and potentially explosive buildup of extreme pressures and temperatures.

According to the National Board Bulletin/Fall 2007, it is a good idea to post signage near the boiler that states something similar to the following:

EXPLOSION WARNING - Do Not Introduce Water Into or Onto an Overheated Boiler

The boiler contains several limit controls to prevent excessive temperatures, but make sure these controls are properly set, maintained, and operated.

Boiler controls must NEVER be bypassed, improperly set, or overridden. If any manual reset control device has been tripped, the boiler control must NEVER be reset until the system has been thoroughly checked by a qualified technician. Failure to follow this warning can result in damage to the vessels and possible serious injury.

The following is a list of *Recommendations for a Boiler Room* derived from the National Board of Boiler and Pressure Vessel Inspectors:

- 1) Keep the boiler room clean and clear of all unnecessary items. The boiler room should not be considered an all-purpose storage area. The burner requires proper air circulation to prevent incomplete fuel combustion and the production of carbon monoxide.
- 2) Ensure that all personnel who operate or maintain the boiler room are properly trained on all equipment, controls, safety devices, and up-to-date operating procedures.
- 3) Before startup, ensure that the boiler room is free of all potentially dangerous situations, like

flammable materials that could cause mechanical or physical damage to the boiler or related equipment. Clear intakes and exhaust vents and check for deterioration and possible leaks.

- 4) Ensure a thorough inspection by a properly qualified inspector, such as one who holds a National Board commission.
- 5) After any extensive repair or new installation of equipment, make sure a qualified boiler inspector re-inspects the entire system.
- 6) Monitor all new equipment closely until safety and efficiency are proved.
- 7) Use boiler operating log sheets, maintenance records, and the manufacturer's recommendations to establish a preventive maintenance schedule based on operating conditions, repair, and replacements performed on the equipment.
- 8) Establish a checklist for proper startup and shutdown of boilers and all related equipment according to the manufacturer's recommendations.
- 9) Observe equipment extensively before allowing automatic operating systems to be used with minimal supervision.
- 10) Establish a periodic preventive maintenance and safety testing program that follows CSD-1-1995, Part CM and the manufacturer's recommendations.

TRIAD reminds end-users that boilers and boiler rooms may fall under many code and regulatory requirements, with local jurisdiction usually controlling. Installation should be carried out by competent personnel in accordance with the standards of the National Fire Protection Association, National or Canadian Electrical Code. However, NEC, ANSI, ASHRAE, UL/IRI/FM, NFPA, state, insurance, and BOCA recommendations must also be considered. Mandatory compliance with ASME code as administered by the National Board may be required in some instances.

TRIAD / SUPERIOR very strongly recommends that a competent and knowledgeable system design engineer be given design and implementation responsibility.

WATER

Properly treated vessel water is highly important, and critical for normal boiler service life and correct operation. This is water free of excessive minerals and gases with a nominal pH of 8.0 – 10.0. A pH level only a single digit away from this recommendation can make a dramatic difference - each increasing level of pH is ten times greater than the prior level. So for example, a pH of 8 is ten times more acidic than a pH of 9, and one hundred times more acidic than a pH of 10. Conversely, a pH of 8 is ten times more basic (alkaline) than pH of 7.

Water Items	Levels
pH	7.5 to 9.5
TDS	<2000 ppm
Hardness CaCO ₃ (Calcium Carbonate)	<10 ppm
Alkalinity	<300 ppm
Organic Carbon	No sheen or Foam (1)
Iron	Colorless Liquid (2)
Suspended Solids	No visual turbidity (3)

- (1) Organic Carbon – After a water sample sits for 10 minutes there should be no visible solids.
- (2) Iron – Hold a water sample against a white background and there should be no visible yellow, red, or orange tinge.
- (3) Suspended solids – Vigorously shake a water sample for 30 seconds. There should be no visible sheen or foam.

Water samples should be taken from the lower part of the boiler, not from an area higher up such as the gauge glass.

Scale is a very effective insulator that will cause a loss of heat transfer efficiency and eventually tube sheet failure. Hard water results in a high amount of suspended solids. This condition is not covered under the boiler warranty.

Water that is too soft can be even more aggressive, so a minimum hardness is usually recommended.

Other items that also are harmful to the boilers include silica, iron, chlorides, and phosphates.

Following are several water treatment terminology items:

Alkalinity – Levels of this determine the ability of acids to be neutralized in water. Alkalinities can form carbon dioxide which is a primary culprit in corrosion. High levels can be from infrequent blowdowns, or an overdose of alkaline water treatment chemical.

Chlorides – The higher the levels, the more

corrosive the water. These can be controlled by increasing the amount of corrosion inhibitor or changing the type of inhibitor used.

Dissolved Oxygen – High levels in the boiler can cause pitting. It is very difficult to stop pitting once it has started, and can proceed very quickly.

Oil – Oil can get into boiler water from various sources, including high levels in a new boiler, or from the condensate. It can contribute to scale formation.

pH – This is a measure of the level of acid or base of water. If too low (acidic) corrosion will increase, if too high then scale can develop. It can also cause water carryover. It is very important to continuously monitor pH levels.

Phosphates – High levels can cause scale formation. It usually comes from some type of pollution in the groundwater.

Sodium Sulfite – This is used to remove dissolved oxygen before it gets to the boiler. It reacts with oxygen to produce sodium sulfate (versus sulfite). Water should have slightly more than enough sodium sulfite to consume all the dissolved oxygen. If not fed continuously, the boiler may not be protected from oxygen corrosion. This is a very important aspect of water treatment.

TDS – Total Dissolved Solids is undissolved organic matter such as dirt and silt in the water. This can cause high water hardness.

A thorough review by a qualified water treatment system specialist should be done, and their recommendations followed.

SUPERIOR BOILER TECHNOLOGIES

Section II

HYDRONIC BOILER MODEL INFORMATION

This section includes a copy of the packing list for your boiler system, the standard configuration by model, and a wiring diagram for future reference.

If you should have a question or need service, it is important that you provide the following information:

Boiler Model, Serial Number, Burner Model, Burner Serial Number, Date of Installation, and Job Number, which is shown in the packing list.

The models and serial numbers can also be found on the boiler registration tags.



WARNING: Please read the manual completely before attempting to place the boilers into service. It is extremely important that all of the information and the burner manufacturer's literature be studied before attempting to operate the boilers. Failure to follow the directions and warnings can result in property damage, or serious injury.

Each TRIAD Boiler is certified to meet or exceed the requirements of the American Society of Mechanical Engineers (ASME) Code for pressure bound vessels. Each boiler is registered with the National Board of Boiler and Pressure Vessel Inspectors (National Board, NBBI). All Series 900 and 1600 Hydronic boilers are UL Listed complete boiler package assemblies. At a minimum all boilers feature UL listed controls.

Superior Boiler Technologies is not responsible for general system design including venting and breeching. System performance will be limited by the total effectiveness of all of its components including combustion air supply.

Treatment of boiler water is necessary to prevent the buildup of sediments, deposits, and for corrosion avoidance. Water must be sampled for specific chemical analysis and an ongoing monitoring program should be set up. An appropriate treatment program as recommended by this Operating and Maintenance Manual and a qualified water treatment company or consultant should be followed to help ensure expected boiler performance.

Specifications subject to change without notice.

The next several pages include:

Copy of Boiler Packing slip
Boiler Wiring Diagram
Standard Configuration Lists by Series

ABBREVIATIONS AND TERMS

ASME -- American Society of Mechanical Engineers -- boiler engineering code specifications.
ATM -- Atmospheric burner, a natural draft burner.
BTU/hr -- British Thermal Unit per hour, heat to raise 1 gallon of water 1°F.
Barometric damper -- device for controlling stack draft; individual per boiler recommended.
Boiler Control Center -- activates burner control on "Call For Heat."
Breeching - sheet metal ducts that carry exhaust from the boiler to the stack.
Burner relay -- control circuit through Boiler Control Center to burner.
Call For Heat -- completion of the thermostat control loop T-TY circuit.
Category I -- non-condensing gas appliance that operates with a non-positive vent pressure.
Coil Circulator -- the coil water secondary loop pump (LT or DHW models).
Combustion Air -- outside air required for correct burner operation.
Cycle -- from call for heat to burner shut-off after call is satisfied.
Dry Fire -- heating a vessel with insufficient water, extremely hazardous.
Fire Tube -- the connector between the firebox and vent, water surrounded, heat inside.
Flash -- water heated above boiling will convert violently to steam on loss of pressure.
Fuel Train -- connects gas or oil supply to burner, controls pressure, contains shut-off valves.
HEP -- Power draft burner; note: Category I venting in a TRIAD boiler.
L.W.C.O. -- Low Water Cut Off -- controls boiler by monitoring water level.
LT -- Low temperature application (coil water).
Lever Test -- safety relief valve, raise manual lever to check operation, releases water pressure.
NBBI -- National Board of Boiler and Pressure Vessel Inspectors, aka: The Board.
Nominal -- under all conditions being within expected parameters.
OEM -- Original Equipment Manufacturer, a purchased product component.
Operator -- someone trained and competent to monitor in-use boiler systems.
Pressure Bound Vessel -- NBBI registered ASME code built boiler shell.
PSIG -- pounds per square inch gauge (vs absolute), typically used as just psi.
Primary-Secondary -- isolated, modular boiler system.
Primary Loop -- main system loop, boiler interface is through secondary loop to header.
Raw Water -- untreated for ph, solids, dissolved minerals and gasses, and organics.
Remove From Service -- properly disconnect and render inoperative.
SH -- Space heating application (vessel water).
Safety Relief Valve -- ASME rated relief valve matched for pressure and heat capacity.
Scale - the solidification of dissolved minerals from water, typically carbonates.
Secondary Circulator -- the vessel water secondary loop pump, space heat application (SH).
Secondary Loop -- the plumbing between the boiler and header (primary) loop.
Sort Cycle -- frequent turning on and off of burner, inefficient.
Sight Glass -- glass port for viewing firebox.
Staging -- the controlled firing in sequence of modular boilers to meet varying demands.
System Design Engineer -- responsible for system compliance and specifications.
DHW -- Domestic or service water application (coil water).
Technical Service -- knowledgeable, licensed, trained, experienced, and qualified.
Thermal Shock -- cyclic metal fatigue caused by excessive heat differentials.
Tripped -- a device that has been activated and must be physically re-set.
Tube Sheet -- part of the pressure vessel that retains the tube ends.
Turbulator -- in-firerube device provides mandatory HEP back pressure and heat transfer.
UL -- Underwriters Laboratories.
Venting -- to release to atmospheric pressure, commonly also used to mean breeching.
Water Treatment -- controls ph, hardness, dissolved minerals and gasses, and organics.

**TRIAD SERIES 300 THROUGH SERIES 600 BOILERS
STANDARD AND OPTIONAL COMPONENTS**

SERIES 300 BOILERS:

<u>Model Number</u>	<u>Description</u>
300-SH-ATM or HEP	Space Heat Only
300-LT-ATM or HEP	Low Temperature Only
300-DHW-ATM or HEP	Domestic Hot Water Only
300-SH-C-LT-ATM or HEP	Space Heat With Low Temperature
300-SH-C-DHW-ATM or HEP	Space Heat With Domestic Hot Water
300-SH-C-DP-ATM or HEP	Space Heat With Double Pump

SERIES 600 BOILERS:

<u>Model Number</u>	<u>Description</u>
600-SH- HEP	Space Heat Only
600-LT-HEP	Low Temperature Only
600-DHW-HEP	Domestic Hot Water Only
600-SH-C-LT-HEP	Space Heat With Low Temperature
600-SH-C-DHW-HEP	Space Heat With Domestic Hot Water
600-SH-C-DP-HEP	Space Heat With Double Pump

STANDARD COMPONENTS:

Burners and Pumps:

Series 300:

	SH	LT	DHW	SH-C-LT	SH-C-DHW	SH-C-DP
HA-300PS Gas Burner (ATM Only)	1	1	1	1	1	1
X4-400 Gas Burner (HEP Only)	1	1	1	1	1	1
NRF-33 Circulator for SH	1	0	0	1	1	2
NRF-33 Circulator For LT	0	1	0	1	0	0
NBF-22 Circulator For DHW	0	0	1	0	1	0

Series 600:

X4-700 Natural Gas Burner	1	1	1	1	1	1
PL-75 Circulator	1	0	0	1	1	2
PL-45 Circulator For LT	0	1	0	1	0	0
PL-45B Circulator For DHW	0	0	1	0	1	0

Other Components (Both Series):

L8148E Control Center	0	1	1	0	0	0
Hydrostat Control Center	1	0	0	1	1	1
R845A Control Center (For Coil)	0	0	0	1	1	1
OEM-750P-MT LWCO, Auto Reset	1	1	1	1	1	1
L4006E 2nd High Limit-Man Reset	1	1	1	1	1	1
Burner Control Relay (HEP ONLY)	1	1	1	1	1	1
2620 Operating Light	1	1	1	2	2	2
Pressure/Temperature Gauge	1	1	1	1	1	1
Pressure Relief Valve	1	1	1	1	1	1
3/4" Boiler Drain	1	1	1	1	1	1
Internal Copper Coil	0	1	1	1	1	0

**TRIAD SERIES 300 THROUGH SERIES 1600 BOILERS
STANDARD AND OPTIONAL COMPONENTS**

SERIES 900 BOILERS:

<u>Model Number</u>	<u>Description</u>
900-SH- HEP	Space Heat Only
900-LT-HEP	Low Temperature Only
900-DHW-HEP	Domestic Hot Water Only
900-SH-C-LT-HEP	Space Heat With Low Temperature
900-SH-C-DHW-HEP	Space Heat With Domestic Hot Water
900-SH-C-DP-HEP	Space Heat With Double Pump

SERIES 1600 BOILERS:

<u>Model Number</u>	<u>Description</u>
1600-SH- HEP	Space Heat Only
1600-LT-HEP	Low Temperature Only
1600-DHW-HEP	Domestic Hot Water Only
1600-SH-C-LT-HEP	Space Heat With Low Temperature
1600-SH-C-DHW-HEP	Space Heat With Domestic Hot Water

STANDARD COMPONENTS:

Burners and Pumps:

Series 900:	SH	LT	DHW	SH-C-LT	SH-C-DHW	SH-C-DP
JR30A Natural Gas Burner	1	1	1	1	1	1
PL-75 Circulator	1	0	0	1	1	2
PL-45 Circulator For LT	0	1	0	1	0	0
PL-45B Circulator For DHW	0	0	1	0	1	0
U.L. Listing And Approval	1	1	1	1	1	0

Series 1600:

JR50 Natural Gas Burner	1	1	1	1	1	NA
PL-130 Circulator	1	0	0	1	1	NA
PL-45 Circulator For LT	0	1	0	1	0	NA
PL-45B Circulator For DHW	0	0	1	0	1	NA
U.L. Listing And Approval	1	1	1	1	1	NA

Other Components (Both Series):

L8148E Control Center	0	1	1	0	0	0
Hydrostat Control Center	1	0	0	1	1	1
R845A Control Center (For Coil)	0	0	0	1	1	1
OEM-750P-MT LWCO, Auto Reset	1	1	1	1	1	1
L4006E 2nd High Limit-Man Reset	1	1	1	1	1	1
Burner Control Relay	1	1	1	1	1	1
2620 Operating Light	1	1	1	2	2	2
Pressure/Temperature Gauge	1	1	1	1	1	1
Pressure Relief Valve	1	1	1	1	1	1
3/4" Boiler Drain	1	1	1	1	1	1
Internal Copper Coil	0	1	1	1	1	0

**TRIAD SERIES 2000 BOILERS
STANDARD AND OPTIONAL COMPONENTS**

SERIES 2000 BOILERS:

<u>Model Number</u>	<u>Description</u>
2000-SH- HEP	Space Heat Only
2000-LT-HEP	Low Temperature Only
2000-DHW-HEP	Domestic Hot Water Only
2000-SH-C-LT-HEP	Space Heat With Low Temperature
2000-SH-C-DHW-HEP	Space Heat With Domestic Hot Water

STANDARD COMPONENTS:

Burners and Pumps:

<i>Series 2000:</i>	SH	LT	DHW	SH-C-LT	SH-C-DHW	SH-C-DP
JR50 Natural Gas Burner	1	1	1	1	1	NA
Series 90 Circulator	1	0	0	1	1	NA
PL-45 Circulator For LT	0	1	0	1	0	NA
PL-45B Circulator For DHW	0	0	1	0	1	NA
U.L. Listing And Approval	1	1	1	1	1	NA

Other Components (Both Series):

L8148E Control Center	0	1	1	0	0	0
Hydrostat Control Center	1	0	0	1	1	1
R845A Control Center (For Coil)	0	0	0	1	1	1
OEM-750P-MT LWCO, Auto Reset	1	1	1	1	1	1
L4006E 2nd High Limit-Man Reset	1	1	1	1	1	1
Burner Control Relay	1	1	1	1	1	1
2620 Operating Light	1	1	1	2	2	2
Pressure/Temperature Gauge	1	1	1	1	1	1
Pressure Relief Valve	1	1	1	1	1	1
3/4" Boiler Drain	1	1	1	1	1	1
Internal Copper Coil	0	1	1	1	1	0

SUPERIOR BOILER TECHNOLOGIES

Section III

HYDRONIC BOILER SYSTEM COMPONENTS

TRIAD boilers are designed to very strict standards, certified to meet and exceed American Society of Mechanical Engineers (ASME) codes, and registered with the National Board of Boilers and Pressure Vessel Inspectors (NBBI). In addition, the boiler controls, gas train, and burner should be listed by a recognized agency.

SUPERIOR BOILER uses only UL listed controls and UL or AGA listed burners and gas trains. Each Series 900 and 1600 Hydronic Boiler is a complete UL listed boiler-burner, and control package. It is also a Category I non-condensing gas appliance that operates with non-positive pressure at the vent collar approved for use with Type B venting.

APPLICATIONS:

SH: Space Heating, system nominal temperature of 130-210°F

LT: Low temperature, internal coil water, system nominal temperature 60-130°F

DHW: Domestic hot water, internal coil water, system nominal temperature 120-180°F

TRIAD boilers are listed for a nominal operating temperature of 210°F, a maximum temperature of 220°F, and should never be heated above 240°F.



WARNING: Water heated above boiling temperature can flash to steam with a loss of system pressure.

BTU/hr ratings: See boiler tag for model and rating information.

Series 300 fires 210,000 to 399,000 BTU/hr.
Series 600 fires 600,000 to 700,000 BTU/hr.
Series 900 fires 600,000 to 1,000,000 BTU/hr.
Series 1600 fires 1,100,000 to 1,700,000 BTU/hr.
Series 2000 fires 1,700,000 to 2,100,000 BTU/hr

TYPICAL BURNERS:

<u>Series 300:</u>	<u>Power Burners</u>	<u>Atmospheric</u>
Gas	Powerflame X4-400 or Riello G400	Adams 300
Oil or Dual	Riello F10	N/A
<u>Series 600:</u>		
Gas	Powerflame X4-700 or Riello G750	N/A
<u>Series 900:</u>		
Gas	Powerflame JR30 or Riello RS 28	N/A
Oil or Dual	Powerflame CR1 GO or Riello RLS28	N/A
Low Nox	Powerflame NPM 30	N/A
<u>Series 1600:</u>		
Gas	Powerflame JR50	N/A
Oil or Dual	Powerflame CR2 GO or Riello RLS 38	N/A
Low Nox	Powerflame NPM 50	N/A
<u>Series 2000:</u>		
Gas	Riello RS 50	N/A
Oil or Dual	Powerflame CR2 GO or Riello RLS 50	N/A

TRIAD boilers may be used in many different applications. A hydronic boiler is designed to produce hot water. The amount and temperature of hot water is in direct proportion to the BTU/hr (British Thermal Units per hour) rating of the burner and in inverse proportion to the flow (gallons per minute at the nominal rating of the pump). In a typical space heating application, for example, a 900,000 BTU/hr unit will produce 60 gpm at a 25°F rise.

The same burner/boiler with a different flow rated pump in a domestic hot water application will nominally produce about 15 gpm with a temperature rise of approximately 100°F. The principle difference between the two applications is the size of the secondary circulating pump that controls the flow and thus the output temperature rise. In either case, the BTU/hr transfer is essentially the same. The controlling factors are therefore the BTU/hr rating of the burner and the volume output of the pump.

The major difference between TRIAD's Space Heating Boilers (SH Models) and the Low Temperature/Domestic Hot Water (LT/DHW) models is that the LT and DHW models use the hot water in the vessel to heat water contained in an internal copper coil, thus providing both thermal and direct contact isolation from the vessel water.

For a boiler system to work properly, the boiler, burner, and circulating pump must be matched for performance; the proper model boiler and burner BTU/hr rating must be selected (with the correct circulating pump). The rest of the system must be properly designed to meet the intended needs, and installed to meet both the system's and local code requirements.

ELECTRICAL:

120 volts, 60 Hz, single phase
Series 300 ATM -- 15 amps per boiler
Series 300 HEP -- 20 amps per boiler
Series 900 HEP -- 30 amps per boiler
Series 1600 & 2000 HEP -- 30 amps per boiler



CAUTION: SUPERIOR BOILER recommends that both a master fuel cutoff and a master electrical switch be located and installed to be readily accessible in case of an emergency.

Some local codes require a master power off switch for boiler room equipment and may specify its location. Electrical service and connections must meet all applicable codes.

WATER:

Good water is required and critical to full boiler performance and normal boiler service life:

Quality water free of excessive minerals and dissolved gases, with nominal pH 8.0 – 10.0.

Properly treated vessel water is required for normal boiler service life. A thorough review by a qualified water treatment system specialist is strongly recommended. The use of excessively hard water or high mineral content will result in the buildup of internal scale in the boiler. Soft water may sometimes be even more aggressive, so a minimum hardness is usually recommended.

Scale is a very effective insulator which can cause a loss of heat transfer efficiency. The buildup of mud, sludge, sediment, or scale in the boiler can result in tube sheet failure caused by excessive

heat differentials and is not covered under the warranty. Raw makeup water will contain oxygen and other dissolved gases, minerals, and even organic materials that can lead to premature corrosion failure.

It is strongly recommended that a complete water analysis be performed before system implementation to prevent water related problems which can permanently damage the boiler, coil, and system.

Vessel water (system water in SH applications) should rarely be changed. Each addition of water introduces oxygen into the system that promotes internal rusting that can lead to vessel failure. An air separation system is strongly recommended in such instances or in open system applications.

Some systems use an antifreeze (typically glycol based) additive to protect system (vessel) water from freezing. Up to 50% glycol solution is acceptable, but it is imperative that the fluid used not attack the sealing pipe dope. Leaks arising from the use of such solutions are not covered under warranty. Use of any primary fluid other than water, or water with contaminants voids the warranty.

INDIVIDUAL BOILER CONTROLS:

Individual component product information is included in Section VI (BE SURE TO REVIEW ALL MANUFACTURERS' WARNINGS) and the configuration for your specific boilers are shown in Section II.

Burner manuals are sent separately with the boiler or burner. BE SURE TO SEE THE BURNER MANUFACTURERS' INSTALLATION AND WARNING INFORMATION.

Typical controls used on TRIAD boilers are described below:

HYDROSTAT -- BOILER CONTROL CENTER:

Used on Space Heating (SH) and Combination boilers to control the overall operation of the boiler, including (1) starting the burner; (2) controlling the minimum temperature set-point at which the SH secondary circulator will start; and (3) providing the operating High Temperature Limit for the boiler – the latter two are provided by the dual Aquastat which is built in to this control.

Both the minimum temperature set-point for the SH pump and the Operating High Temperature Limit

must be set in this control for each boiler before starting up.

This control is wired in series with the Low Water Cut-off control (LWCO) and will activate only if a low water condition does not exist. See LWCO for further information.

This control is activated by closing the circuit between the two low voltage terminals (T-T) via a 24 vac, 2-wire thermostat or a control panel. This situation is known as a “Call For Heat”. The operating light will illuminate when the secondary circulator for Space Heating (SH) is activated by the control.

In normal operating conditions, with a “Call For Heat”, this control will switch on the burner relay which starts the burner operating sequence. The SH secondary circulator will start once the vessel water temperature reaches the minimum temperature set-point. Both the burner and the pump will continue to operate until the “Call For Heat” requirement has been satisfied, at which time this control will be de-activated and the circuit (T-T) is opened.

NOTE 1: The burner will stop running if the vessel water temperature exceeds the Operating High Temperature Limit set-point of this control – the burner will restart once the vessel water temperature drops below the differential of the Operating High Temperature Limit set-point. The SH pump will continue to operate during this condition or until the “Call For Heat” requirement is satisfied.

NOTE 2: This control will deactivate if a low water condition exists – see LWCO.

R845A -- AUXILIARY CONTROL RELAY:

Used on Combination boilers as an add-on or second control system to manage only the operation of the LT/DHW coil application by (1) indirectly starting the burner by interfacing with the Hydrostat control; and (2) directly starting the LT/DHW secondary circulator.

Because the R845A control works through the Hydrostat control to activate the burner, the R845A also operates as an “add-on” to the other controls (ie; LWCO, L4006E, etc.) on the boiler in controlling the operation of the boiler.

The R845A control is activated by closing the circuit between the two low voltage terminal (T-T)

via a 24VAC 2-wire thermostat or a control panel otherwise known as a “Call For Heat”. The operating light will illuminate when the control is activated.

L8148E-- LT/DHW CONTROL CENTER: (Single Function Boilers Only)

Used on single function – LT/DHW boilers to control the overall operation of the boiler including: (1) starting the burner; (2) starting the LT/DHW coil circulator; and (3) providing the Operating High Temperature Limit for the boiler.

The Operating High Temperature Limit must be set in this control for each boiler before initial start up. This control is wired in series with the Low Water Cut-off control (LWCO) and will activate only if a low water condition does not exist. See LWCO for further information.

This control is activated by a “Call for Heat” that closes the circuit between the two low voltage terminals (T-TV) via a 24VAC 2-wire thermostat or a control panel. The operating light will illuminate when the control is activated.

NORMAL OPERATING CONDITIONS: With a “Call For Heat”, this control will switch on the burner relay which will start the burner operating sequence and immediately start the secondary circulator pump. Both the burner and the circulator pump will continue to operate until the “Call For Heat” requirement has been satisfied, at which time this control will be de-activated and the circuit (T-T) opened.

NOTE 1: The burner will stop running if the vessel water temperature exceeds the Operating High Temperature Limit set-point of this control – the burner will restart once the vessel water temperature drops below the Operating High Temperature Limit set-point minus the differential. The secondary pump will continue to operate during this event or until the “Call For Heat” requirement is satisfied.

NOTE 2: This control will deactivate if a low water condition exists – see LWCO.

L4006E -- SECOND HIGH LIMIT-MANUAL RESET:

This aquastat control provides a second safety high water temperature monitor and shutoff but with a manual reset requirement. It acts as the maximum

vessel water control limit. It is wired in series with the burner control circuit or, in the case of small atmospheric burners, with the low voltage power circuit.

The Maximum Safety High Temperature Limit must be set in this control for each boiler before starting up. It should NEVER be set higher than 240 degrees.

The L4006E will open its control circuit and stop the operation of the burner when the vessel water temperature meets the Maximum Safety High Temperature Limit set-point of the control.

The boiler/burner can only be restarted by "manually" resetting this control. However, before resetting this control, the cause of the High Limit cutoff must be found and corrected. Continuous shut off on high limit will damage the boiler and burner and cause unneeded burner cycling.

LOW WATER CUT OFF (LWCO): 750-MT Manual Reset

This unit senses the water level within the vessel shell. The circuit will open, removing power from the Boiler Control Center if the vessel water level falls below the controller probe. "Dry firing" (operating a boiler with insufficient water) is an extremely destructive and dangerous practice. See Section I.

RELIEF VALVE:

This is matched for the correct BTU/hr load and pressure. Typical is 30 psi for the Series 300; 45 psi for the Series 900; and 50 psi for the Series 1600 and 60 psi for the 2000.

The relief valve should NEVER function under normal operations. If it has then something needs to be adjusted. Many codes require periodic testing and replacement of relief valves -- the user must meet local code requirements. Relief valves are sized for both their pressure rating and their BTU/hr load. Replace only with properly sized, ASME approved units. Field plumbing is required and certain restrictions apply -- SEE MANUFACTURER'S TAG ATTACHED TO VALVE.

FLOW CHECK VALVES:

Secondary loop vertical lift flow check valves that function to normally prevent gravity flow and open with pump startup.

SYSTEM COMPONENTS

CLEAN-OUT OPENINGS (Optional):

Piped and capped fittings for easier inspection and boiler vessel service.

PUMPS (ITT Bell and Gossett):

NRF-33 (300 SH/LT)
NBF-22 (300 DHW)
PL-75 (900 SH),
PL-45 (900 through 2000 LT),
PL-45B (900 through 2000 DHW)
PL-130 (1600 SH)
Series 60 (2000 SH) (Shipped Loose)

These are the secondary loop circulation pumps intended to connect the boiler to the primary main system loop.

PRESSURE/TEMPERATURE GAUGE:

Non-precision indicator of the approximate boiler vessel operating temperature and pressure.

BURNER RELAY (OPTIONS): FAN DAMPER, OR LOCKOUT RELAYS SQUARE D 8501 DPDT (With Low Voltage Or Line Voltage Coil)

The burner relay is part of the primary boiler control circuit. Additional relays may be mounted for field installed add-on circuit controls.

BAROMETRIC DAMPER (OPTIONAL): FIELD MG1-7, RC-6, RC-9

Recommended that at least one barometric damper be installed for each boiler or a minimum of one before the first boiler and the stack.

OPERATING LIGHT:

Call For Heat indicator mounted in Boiler Control Center and Auxiliary Control Relay.

SYSTEM COMPONENTS:

Besides the boiler and its components, a complete heating system may have some or all of the following:

Primary Loop And Pump -- connects to boiler secondary loop by the header which then transfers to the secondary heating zone pumps and loops.

Air Separation System -- removes dissolved gases

SECTION III

from recirculating system water, which TRIAD highly recommended for open systems.

Water Treatment System -- helps ensure water quality, control ph, hardness, and dissolved materials.

Vent and Expansion System – Because heated water expands, a properly sized tank (or tanks) is required to provide a buffer and contain the heated system water expansion.

Water Pressure Reducing Valve -- drops supply water to system pressure and maintains a minimum (18 psig) pressure within the system.

Gas Line Pressure Valve -- lowers supply gas pressure to gas train range (typically less than 14" wc -- 0.5 psi).

Oil Supply System -- allows single or two line transfer of fuel oil from the supply tank to the burner train.

Thermostat Control-- varies between a simple two wire thermostat to a microprocessor outdoor reset control panel. Some applications may use a remote Aquastat or a suitable application sensor which closes the boiler thermostat "Call For Heat" control circuit.

SUPERIOR BOILER TECHNOLOGIES

Section IV

GENERAL OPERATIONS

Prior to starting the boiler system, please familiarize yourself with each boiler control by reviewing Section III and VI of this manual.

It is imperative that initial settings for each control (ie: Safety High Temperature Limit) be completed before attempting to start up a boiler.

All TRIAD boilers are equipped with a Control Center with an adjustable, high temperature limit, a low water cutoff (LWCO) control and manual reset, and a high temperature limit control. Other controls may be installed as add-on options.

Unless otherwise noted, all control circuits and wiring connections are line voltage.

All Control Centers require a "Call For Heat" to be activated. This is accomplished by closing the circuit between the two low voltage terminals (T-T) via a 24 vac 2-wire thermostat; a control panel; a simple temperature control or an on/off switch.



Power is supplied to the boiler by setting the On/Off switch to the ON position. With this switch in the On position, all of the controls on the boiler are "live" and great caution must be taken before touching any wiring. Turning the On/Off switch to OFF means only that the power to the boiler mounted controls is off.

NOTE: Power to controls and systems not mounted on the boiler (fan dampers, induced draft fans, etc.) is not provided by the boiler controls even though these systems may be activated by boiler mounted relays, etc.

NORMAL Operating Conditions exist when the vessel water temperature is not above the operating high limit – see Hydrostat/ L8148E control and a low water condition does not exist – see LWCO control.

ABNORMAL Operating Conditions include, but are not limited to; electrical failure, fuel interruptions, vessel water temperature exceeding control set points, a low water condition, a malfunctioning control, etc.

Specific wiring diagrams for your boiler system are included in Section II of this manual.

Descriptions of controls and their operations are generic and are included in Section III. Specifications and configurations are subject to change without notice.

SH MODELS:

These single function boilers provide space heating (SH) hot water using the vessel water as the source for the application and a separate pump on each boiler to circulate the vessel water to and from the main building heating loop.

SETTINGS:

Boiler Control Center:

Operating High Temperature Limit or nominal vessel operating temperature typically not to exceed 210°F.

Second (Safety) High Limit:

Nominal vessel operating temperature plus 10°F-15°F but NEVER to exceed 240°F.

OPERATION:

Under Normal Operating Conditions a "Call for Heat" to the Hydrostat control would activate the burner control circuit, which energizes the relay to start the burner operating cycle and illuminate the operating light on top of the control. Once the vessel water temperature reaches the minimum temperature set point as established in the Hydrostat control, the SH pump will start to operate.

NOTE 1 – The burner will stop running if the vessel water temperature exceeds the Operating High Temperature Limit set point of the Hydrostat control – the burner will restart once the vessel water temperature drops below the differential of the Operating High Temperature Limit set point. The SH pump will continue to operate during this condition or until the "Call for Heat" requirement is satisfied.

NOTE 2 – The Hydrostat will de-activate if a low water condition exists – see LWCO.

NOTE 3 – In the event that the HYDROSTAT Operating High Temperature Limit would fail for whatever reason, the boiler is protected with an additional high temperature control – the L4006E – that provides a Maximum Safety High Temperature Limit which requires a manual reset if activated. See Section III for a more detailed description.

The boiler will continue to operate until the “Call For Heat” is satisfied and the control is deactivated by opening the circuit (T-T) or an ABNORMAL Operating Condition develops.

LT and DHW MODELS:

These single function models provide an isolated, hot water source from an internal copper coil that segregates the application water from the boiler water. By using an internal coil to provide application water, TRIAD boilers can operate at optimum boiler water temperatures (typically 140°F-220°F) without condensing while providing different temperature water for the application. The water in the coil is “indirectly fired” by the vessel water, which allows for lower temperatures than those of the vessel water.

SETTINGS:

Boiler Control Center:

Operating High Temperature Limit or nominal vessel operating temperature typically not to exceed 210°F.

Second (Safety) High Limit:

Nominal vessel operating temperature plus 10°F-15°F but NEVER to exceed 240°F.

For the Coil Application:

Low Temperature (LT) applications – typically run between 60°F -130°F.

Domestic hot water applications (DHW) typically run between 120°F -180°F.

OPERATION:

Under Normal Operating Conditions a “Call for Heat” to the L8148E control center would activate the burner, start the coil pump, and illuminate the operating light mounted on this control.

NOTE 1 – The burner will stop running if the vessel water temperature exceeds the Operating High Temperature Limit set point of the L8148E control – the burner will restart once the vessel water

temperature drops below the Operating High Temperature Limit set point. The coil pump will continue to operate during this condition or until the “Call for Heat” requirement is satisfied.

NOTE 2 – This control will de-activate if a low water condition exists – see LWCO.

NOTE 3 – In the event that the L8148E Operating High Temperature Limit would fail for whatever reason, the boiler is protected with an additional high temperature control – the L4006E – that provides a Maximum Safety High Temperature Limit which requires a manual reset if activated. See Section III for a more detailed description.

The boiler will continue to operate until the “Call For Heat” is satisfied and the control is deactivated by opening the circuit (T-T) or an ABNORMAL Operating Condition develops.

COMBINATION MODELS:

Combination boiler models provide hot water for multiple and separate uses such as Space Heating (SH), which is the “vessel water side”, in combination with a low temperature application (LT) or a domestic hot water application (DHW). Each of these additional applications is provided via the internal copper coil, which is the “coil water side”.

Combination boiler models have two unique electrical control systems that work together to manage the operations of the boiler and burner, yet separately to support their own individual functions. Either control system can have a “Call For Heat” that will cycle the boiler/burner combination under Normal Operating Conditions.

SETTINGS:

Boiler Control Center:

Operating High Temperature Limit or nominal vessel operating temperature typically not to exceed 210°F.

Second (Safety) High Limit:

Nominal vessel operating temperature plus 10°F-15°F but NEVER to exceed 240°F.

For the Coil Application:

Low Temperature (LT) applications – typically run between 60°F -130°F.

Domestic hot water applications (DHW) typically run between 120°F -180°F.

OPERATION:

SH “vessel water side” –

Control and operating of the SH side of combination boilers is exactly the same as the standard SH-only boiler model.

LT/DHW “coil water side –

In Combination boiler models the coil side of the boiler is managed by its own Control Center – and R845A switching relay – see Section III for further details about this control. Because the R845A control works through the Hydrostat control to activate the burner, the R845A also operates as an “add-on” to other controls (i.e.; LWCO, High Limit, etc.) used in the Hydrostat control loop.

Under NORMAL Operating Conditions a “Call for Heat” to the R845A would signal the Hydrostat control to activate the burner if it was not already started, start the coil pump, and illuminate the operating light mounted on this control.

NOTE 1 – The burner will stop running if the vessel water temperature exceeds the Operating High Temperature Limit set point of the Hydrostat control – the burner will restart once the vessel water temperature drops below the differential and Operating High Temperature Limit set point. The coil pump will continue to operate during this condition or until the “Call for Heat” requirement is satisfied.

NOTE 2 – This control will de-activate if a low water condition exists – see LWCO.

NOTE 3 – In the event that the Hydrostat Operating High Temperature Limit would fail for whatever reason, the boiler is protected with an additional high temperature control – the L4006E – that provides a Maximum Safety High Temperature Limit which requires a manual reset if activated. See Section III for a more detailed description.

The boiler will continue to operate until the “Call For Heat” is satisfied and the control is deactivated by opening the circuit (T-T) or an Abnormal Operating Condition develops. In Combination boilers, the Space Heating (SH) side may have an unsatisfied “Call For Heat” which will keep the boiler operating under Normal Operating Conditions.

SUPERIOR BOILER TECHNOLOGIES

Section V

INSTALLATION & STARTUP INSTRUCTIONS



STOP: Before going on with this section, carefully read Section I and Section VI, and review the other Sections in this manual.



CAUTION: Before connecting the fuel supply and burner, be sure to read the burner manufacturer's manual.



WARNING: BEFORE ATTEMPTING ANY ELECTRICAL SERVICE DISCONNECT POWER FROM THE BOILER.

Only a qualified, trained individual such as a licensed electrician, should attempt to analyze electrical or control circuits and only a qualified, trained individual such as a licensed plumber or HVAC technician should attempt to service plumbing.

1. The installation must conform to the local codes having jurisdiction over your area and this type of equipment, or without such requirements, to the National Fuel Gas Code (as applicable). At a minimum BOCA code compliance must be met. Where required by the authority having jurisdiction, the American Society of Mechanical Engineers (ASME) Safety Code for Controls and Safety Devices for Automatically fired Boilers No. CSD-1 must be met. In some specific instances ASME code as administered by the National Board must be met. User insurance requirements may also be factors. State inspection or operating restrictions may apply.

2. Superior Boiler Technologies does not do boiler room design nor do we supply many of the components needed in a complete heating system implementation. TRIAD strongly recommends that a competent system design engineer be given the responsibility for heating system design, installation, and operation.

BOTH A READILY ACCESSIBLE MASTER POWER DISCONNECT SWITCH AND A FUEL SYSTEM CUT OFF VALVE ARE

RECOMMENDED.

NEVER "dry fire" a boiler (operate the burner with insufficient water in the boiler and system). Be sure that the combustion air and breeching, venting, fuel supply, and water supply, circulating system, and the expansion tank(s) have been properly installed before attempting to fire the burner. Burner startup procedures are found in the respective burner manufacturer's instruction book. Be sure to read, understand, and heed all warnings.

UNPACKING:

Protect boilers from the weather until ready to install.

This manual is shipped separately.

All cartons and crates should immediately be inspected for any damage. If any damage is found at the time of delivery, proper notation should be made on the carrier's Bill of Lading before signing for delivery. Damage claims should be filed immediately with the carrier. Claims of shortages should be filed in writing with Superior Boiler Technologies within five (5) days of receipt.

The boiler is shipped in an individual crate, completely assembled and wired. Space heating (SH) model pumps are typically mounted on the boiler. Coil and combination models have their pump and secondary fittings shipping in cartons included within the crate. Also included are the leveling bolts and (depending on the model) other needed hardware.

The Series 300 ATM boilers have the burner mounted and the instruction manual should be found in the Instructions Envelope.

The HEP burner model boilers are usually shipped without the burner mounted. The HEP burner carton will contain the manufacturer's instruction manual and partially assembled gas train.

The optional main(s) is shipped in a separate crate(s). The optional microprocessor control

panel is shipped in a separate carton and the keys, sensors, and the instruction manual are inside the control panel box.

The wiring diagram for the boiler is included in this manual and a copy is included in the electrical wiring box. Suggested piping diagrams are available in TRIAD's Boiler Manual.

The boiler contains several identification markings. The boiler tags should be checked to confirm the boiler model and serial number, and burner model and rating. These should agree with the information contained on the copy of the Packing Slip found in Section II of this manual.

LOCATION

Boilers must be protected from weather and should not be exposed to potentially freezing temperatures. The boiler should be located as near as possible to the stack of the breeching system. Consideration should be given to water drainage for the relief valve and for boiler service. Install the boiler only on a level, non-combustible surface. Level the boiler by using the adjustable leveling bolts provided.

Sufficient clearance is required for operation and service. Suggested minimum clearance from the front is 48" and to the flue connection is 18". So, for a Series 900 boiler the minimum ceiling clearance should be 90", based on boiler height of 66", trim height of 18", and flue clearance of 9".

Manifolding separation distance is nominally based on 6" side spacing (as allowed by local code) which is equivalent to 24 inches on center lines for our Series 300 and 36 inches on center lines for the Series 900. See the Boiler Manual for more detail.

The rise in the connector of a combined breeching system can be its most effective part. Generally, the greater the initial breeching rise, the better the system will draft. A draft hood or barometric damper is generally recommended for each boiler or at least one damper should be located between the first boiler and the stack. Additional information is available in the Boiler Manual. Also, local codes must be complied with.

Adequate combustion air must be provided. Provisions for adequate water supply and treatment, and an expansion system must be made. Fuel supply and electrical service must be provided. Stack and breeching components must be provided. Typically, burner startup service will

be required.

Once the burner has been installed and set, the system may be adjusted.

INSTALLATION - BOILERS:



WARNING: Failure to properly design, install, and maintain boiler systems can cause high levels of Carbon Monoxide, risk of boiler damage, or personal injury.



WARNING: Before attempting electrical service disconnect power from the boiler.

CAUTION: Design, installation, and operation should only be done by qualified individuals familiar with HVAC systems, burner setup, and local code requirements. Read the burner manufacturer's manual before connecting the fuel supply and burner.

Hook-ups to the water, breeching, and electrical supplies must be installed and must meet all applicable codes. These may include (but are not necessarily limited to) the National Electrical Code, BOCA standards on Combustion Air, and local water, power, and fuel supplier requirements. On-site inspection by local, state, or third party insurance agents may be required before placing the boiler or system in operation.

TRIAD recommends that all water connections be completed prior to the connection of fuel and electrical power. This will help to ensure that a dry fire situation is avoided and reduce the possibility of spraying water over live electrical components.

All pipes to the boiler between the main and secondary loops are typically sweated. All fittings should be tight and an appropriate sealant (pipe dope) applied. After completing the secondary connections, the boiler, all lines, and the system should be thoroughly flushed.

The safety relief valve should be plumbed in accordance local code and compliant with the manufacturer's recommendations. See the tag attached to the relief valve. The valve should be installed in a vertical upright position with no unnecessary intervening pipe. Under no circumstances should there be a shut off valve or restriction of any kind between the safety valve and the connection. Do not cap or plug the drain hole in the valve body.

Many codes require discharging to the outside atmosphere. Use discharge pipe of size equal or larger than the valve outlet. Use schedule 40 discharge pipe, not schedule 80 nor extra strong pipe to avoid undue stress on the valve. It must allow for easy draining of condensate at or near the valve outlet and must terminate freely to the atmosphere.

Typically, the discharge line should not be restricted or downsized in any way and should be directed to the appropriate drain. The end should have no fitting and be left clearly visible so that if the relief valve should operate it will be obvious that a discharge has occurred.

Fill the system through an appropriate pressure reducing valve (18 psig minimum) and ensure that the expansion system is properly set according to the manufacturer's and system design engineer's requirements. Vent and pressurize the system as required. Typically a minimum of 18 psig system pressure is recommended to avoid inadvertent steam production. Check the water treatment, and expansion system components.

The LWCO's should be plumbed according to local code and the manufacturer's instructions. Typically the discharge lines must not be restricted or downsized; and should be aimed to reduce the potential exposure of steam and hot water release. The ends of the discharge lines should have no fitting. The relief valve line should be left clearly visible so that if it should operate it will be evident that a discharge has occurred.

Flush, connect and test all system water lines.

Fill the boiler(s) and verify that the boiler water level is met and there are no leaks in the system.

Once filled, the boiler should be fired soon to drive off dissolved gases including oxygen to limit corrosion exposure.

INSTALLATION – FUEL DELIVERY SYSTEM

STOP: Check the burner manufacturer's manual before proceeding.

The burner connections warrant special attention. Be sure that the recommendations and warnings provided in the burner manufacturer's manual are followed. Specific limits and procedures to cover fuel line installation, piping, pressure, and leak detection are important to review and understand.

Generally, gas HEP burners should not receive over 0.5 psi (14 inches water column) of gas supply pressure from lines of sufficient volume to avoid an undue pressure drop (see the burner manufacturer's manual). This typically requires a gas line pressure regulator before the gas train.

Oil supply systems may be one or two line depending on the burner and system design. LP systems require pressure regulators and LP specific burners.

The burner should not be connected to the fuel supply line until all testing and leak detection is completed.

Ensure that the fuel supply is shut off at its source. Physically confirm that the firebox is clear of all foreign material. If the burner has not been factory mounted then mount the burner and complete the fuel supply.

Take care while working on fuel lines to avoid ignition sources. Fuel lines should be checked with an appropriate leak detection fluid or procedure. Many fuel supply companies can provide assistance in appliance connections.

Complete the electrical connections to the boiler power and control circuits. Copies of the wiring diagram are in Section II of this manual and on the boiler. The burner and the secondary circulation pump(s) typically receive their power through the boiler control circuits. All wiring must meet local codes.

THE BURNER

The burner should not be connected to the fuel supply line until all testing and leak detection of the fuel delivery system is completed

STOP: The burner connections warrant special attention. Verify that the recommendations and warnings in the OEM's burner manual are followed.

1. Verify that the fuel supply is shut off at its source.
2. Verify that the firebox is clear of all foreign material or fuel and that the refractory is intact
3. Mount the burner on the adapter plate supplied with the boiler using the gasket or insulating rope supplied with the burner.

4. Connect the wiring harness to the burner contacts as shown on the wiring diagrams included with the boiler and in this manual.

5. Connect the fuel source to the burner.

6. The burner must be properly adjusted and set up for each site before operation. All burners use both automatic pilot ignition and some form of flame detection. NEVER try to manually light a burner.

7. Make sure all fuel feed valves remain closed.

For proper combustion is it critical to have sufficient fresh air for the burner. **Make sure there is at least one square inch of opening of fresh air for every 3,000 Btu input.** For proper ventilation install two fresh air openings, one 24" from the floor and one at a high level to make sure hot air is exhausted from the boiler room.

If a direct sidewall connection to bring in outside combustion air is installed, make sure the vent is designed for a pressure drop of no greater than .10" wc. So be aware of length, diameter and elbows.

Do not install any exhaust fans in the boiler room, this can starve the boilers of air resulting in poor combustion, and create a downdraft in the stack.

ELECTRICAL CONNECTIONS

FIRST – Verify that the line voltage power is off and the Call For Heat control (thermostat) is off.

Connect the line voltage service to L1 and L2 terminals in the electrical wiring box on the boiler.

Connect the low voltage (thermostat) circuit to the T1 terminals in the wiring box on the boiler.

IMPORTANT STEPS LEADING TO STARTUP:

Confirm that breeching integrity and combustion air requirements are met and no combustibles or vapors are present.

Flush, connect, and test all system water lines.

Verify that the boiler (water level) is filled.

Test the safety relief valve.

Connect and test the fuel lines.

Connect electrical lines including low voltage "Call for Heat" control lines.

And, follow the burner manufacturer's startup instructions.

STEPS IMMEDIATELY PRIOR TO STARTUP:

Check that the power is off and the Call For Heat control signal is off.

Check all ventilation and combustion air openings and louvers to ensure they are clean and free of debris.

No combustibles or vapors are present in the boiler room.

Check that all stack and breeching dampers are set.

Physically examine the boiler fire box to ensure it is clear of all foreign materials and fuel and that the refractory is intact.

Check that all flue and breeching passages are clear of any fuel accumulations.

Make sure all fuel feed valves are closed.

The burner must be properly adjusted and set for each site before operation. All burners use both automatic pilot ignition and some form of flame detection. NEVER try to manually light a burner.

Confirm that the system design engineer has completed all mandatory code installation requirements including necessary inspections.

Ensure that water treatment, expansion, air separation, fill, and primary loop components are operational per manufacturers' instructions.

Apply fuel, power, and control signals only when, and as, directed in the burner manufacture's manual and after all system and pre-start checks have been completed.

Check that all operating controls are set.

Check that all interlocks (safety controls) are set.

Ensure that the burner pre-purge cycle, ignition, and ignition confirmation circuits are functional before opening fuel feed valves.

Follow the Burner Manufacturer's startup

instructions.

IMMEDIATELY AFTER FIRING:

Monitor the initial ignition cycle carefully for proper operation.

Continue to monitor initial operations and adjust the burner as required for correct operation. Note the combustion products readings for future performance monitoring and ensure operations are on the correct side of the curve - excess oxygen.

Continue with a normal shutdown. Observe the burner for correct response and physically inspect the burner and firebox sight glass to ensure that the flame has been completely cut off.

Closely monitor several complete cycles to confirm proper operation. Ensure that all of the steps in the burner manufacturer's instructions have been completed.

Complete Operator training. Begin keeping a Maintenance Log -- record all startup readings.

Balance the system to the design engineer's specifications by adjusting flow, control, and temperature settings. Some "trial and error" is inevitable.

Section IV covers typical boiler operating sequences and controls.

Section VII covers Maintenance and Section VIII Troubleshooting (for qualified technical support only).

CLEANING THE BOILER (BOIL OUT/SKIMMING)

New boilers need to be thoroughly cleaned before being placed into normal operations. After installation and before the boiler is officially in service the pressure vessel should be cleaned of any oil film, dirt, and other impurities. The boiler should be ready for firing and the operator should be fully familiar with the operation of the boiler and burner and follow instructions contained in those manuals. The operating conditions of all auxiliary equipment should be formally checked out.

Boil outs and skimming the water surface are methods of cleaning a boiler and the system to remove oils and contaminants from the water. It is performed by heating the boiler to temperature and

then skimming off the top of the water at the water line. New boilers require repetitive cleaning during the first few weeks of continuous operation.

It is usually best to let the boiler operate for several days to clear out the system before doing the initial cleaning operation. See section VII.

SUPERIOR BOILER TECHNOLOGIES

Section VI

OEM COMPONENT MANUALS

It is imperative that the instruction information in this section is reviewed before placing the boiler in operation.

These materials include specific operating warnings that must be followed for proper boiler operations.

Failure to follow the directions and warnings can result in damage to the boilers and other property, and serious personal injury.



CAUTION: It is important to pay special attention to the burner manufacturer's installation and instruction manual.

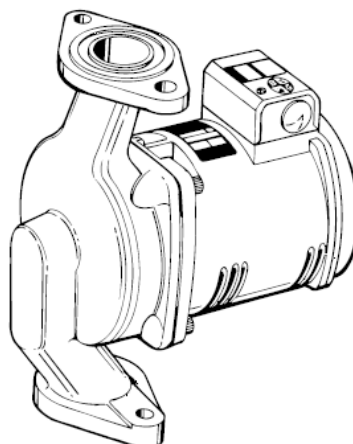

SERIES PL™ Booster Pumps

Installation, Operation, & Service Instructions

INSTALLER: PLEASE LEAVE THIS MANUAL FOR THE OWNER'S USE.

NOTE: Bell & Gossett recommends Bronze Booster Pumps be used for pumping potable water

 **SAFETY INSTRUCTIONS**

This safety alert symbol will be used in this manual and on the pump safety instructions decal to draw attention to safety related instructions. When used, the safety alert symbol means **ATTENTION! BECOME ALERT! YOUR SAFETY IS INVOLVED! FAILURE TO FOLLOW THE INSTRUCTIONS MAY RESULT IN A SAFETY HAZARD.**

Your Series PL™ Booster Pump should have the warning/caution label (Fig. 1) displayed on the pump conduit box. If this warning and caution is missing or illegible, contact your local Bell & Gossett Representative for a replacement.

DESCRIPTION

The Series PL™ Booster Pump features permanently lubricated bearings, non-overloading permanent split capacitor motor with thermal protection and quiet operating construction.

OPERATIONAL LIMITS

These pumps are designed to pump liquids compatible with their iron or bronze body construction.

Maximum Working Pressure: 150 psi (10 bar)
 Maximum Operating Temperature: 225°F (107°C)
 Electrical Rating: 115V, 60 Hz, 1PH
 230V, 60 Hz, 1PH

Do not exceed these values.



FIG. 1

PUMP APPLICATION

The Series PL™ Booster Pump may be used for water circulating applications in hydronic and solar systems.

Bell & Gossett



SAFETY REQUIREMENTS

MECHANICAL SAFETY

⚠ WARNING: EXCESSIVE SYSTEM PRESSURE HAZARD

The maximum working pressure of the pump is listed on the nameplate – DO NOT EXCEED THIS PRESSURE. Failure to follow these instructions could result in serious personal injury, death and/or property damage.

⚠ WARNING: EXCESSIVE PRESSURE HAZARD – VOLUMETRIC EXPANSION

The heating of water and other fluids causes volumetric expansion. The associated forces may cause failure of system components and the release of high temperature fluids. This can be prevented by installing properly sized and located compression tanks and pressure relief valves. Failure to follow these instructions could result in serious personal injury, death and/or property damage.

THERMAL SAFETY

⚠ WARNING: EXTREME TEMPERATURE HAZARD

If the pump, motor, or piping are operating at extremely high or low temperature, guarding or insulation is required. Failure to follow these instructions could result in serious personal injury, death and/or property damage.

ELECTRICAL SAFETY

⚠ WARNING: ELECTRICAL SHOCK HAZARD

Electrical connections are to be made by a qualified electrician in accordance with all applicable codes, ordinances and good practices. Failure to follow these instructions could result in serious personal injury, death and/or property damage.

⚠ WARNING: ELECTRICAL GROUNDING HAZARD

Adequate electrical grounding is required for the safe operation of B&G Pumps. The use of grounded metal conduit assures this requirement. If the means of connection to the supply-connection box (wiring compartment) is other than grounded metal conduit, ground the pump back to the service by connecting a copper conductor at least the size of the circuit conductors supplying the pump to the green grounding screw provided within the wiring compartment. Failure to follow these instructions could result in serious personal injury, death and/or property damage.

This pump is for indoor use only.

REMOVAL OF THE PUMP FROM EXISTING SYSTEM FOR REPLACEMENT

⚠ WARNING: ELECTRICAL SHOCK HAZARD

Disconnect and lockout the power before servicing. Failure to follow these instructions could result in serious personal injury or death.

1. Close the valves on the suction and discharge sides of the pump. If no valves have been installed, it may be necessary to drain the system.

⚠ WARNING: HOT WATER HAZARD

Before draining the system, allow water to cool to 100°F max. open the drain valve (take precautions against water damage) and leave the drain valve open until servicing is complete. Failure to follow these instructions could result in serious personal injury, death and/or property damage.

⚠ WARNING: ELECTRICAL SHOCK HAZARD

Be certain the electrical power is not present at the motor leads before continuing. Failure to follow these instructions could result in serious personal injury or death.

2. Loosen the conduit box cover screw and remove the cover.
3. Disconnect the electrical supply lines to the pump.

⚠ WARNING: HIGH PRESSURE HAZARD

Pressure may be present in the pump body. This pressure can be relieved by loosening the flange bolts and shifting the pump assembly slightly to allow the pressurized water to escape. Failure to follow these instructions could result in serious personal injury or death.

4. Remove the flange bolts and nuts and then remove the pump from the piping.

PUMP INSTALLATION

Locate the pump so there is sufficient room for inspection, maintenance and service. Bell & Gossett recommends the installation of service valves on the suction and discharge of all pumps to facilitate servicing or replacement of the pump without draining the system.

Install suction and discharge flanges on the pipe ends. The use of Teflon® tape sealer or a high quality thread sealant is recommended.

Be sure to minimize any pipe-strain on the pump. Support the suction and discharge piping by the use of pipe hangers near the pump. Line up the vertical and horizontal piping so that

the bolt-holes in the pump flanges match the bolt-holes in the pipe flanges. (DO NOT ATTEMPT TO SPRING THE SUCTION OR DISCHARGE LINES IN POSITION. THIS MAY RESULT IN UNWANTED STRESS IN THE PUMP BODY, FLANGE CONNECTIONS AND PIPING.) The code for Pressure Piping (ANSI B31.1) lists many types of supports available for various applications.

Bell & Gossett flange gaskets must be installed between the Series PL™ pump body flanges and the suction and discharge pipe flanges. Use 7/16" diameter x 1 1/2" long capscrew and matching nut to connect the pump to the flanges.

*Teflon® is a registered trademark of E.I. DuPont de Nemours and Company.

⚠ WARNING: HOT WATER HAZARD
When disassembling a gasketed joint, always use a new gasket upon reassembly. NEVER RE-USE OLD GASKETS. Failure to follow these instructions could result in serious personal injury, death and/or property damage.

Apply torque in even increments to both flange bolts until a value of 96-132 in-lbs. is reached. Both the suction and discharge flange bolts must be torqued in this manner.

⚠ WARNING: WATER LEAKAGE HAZARD
To prevent leakage, make certain that the flange bolts have been adequately torqued. Failure to follow these instructions could result in serious personal injury and/or property damage.

WIRING INSTRUCTIONS

⚠ WARNING: ELECTRICAL SHOCK HAZARD
Disconnect and lockout the power before making electrical connections. Failure to follow these instructions could result in serious personal injury or death.

- A. Loosen the screw securing the conduit box cover (wiring compartment), and remove the screw & cover.
- B. Attach the appropriate size connector to the hole on the side of the conduit box.
- C. Using a minimum size 14 AWG copper electrical wire (refer to your local code for wiring restrictions), wire the motor to a single phase power source as listed on the pump nameplate. See Fig. 3.
- D. Connect the ground wire to the inside of the conduit box with one of the green screws provided inside the box. See Fig. 4.

NOTE: Electrical supply and grounding wires must be suitable for at least 90°C (194°F).

NOTE: Series PL™ Booster Pumps are thermally protected and do not require external overload protection.

⚠ WARNING: ELECTRICAL SHOCK HAZARD
Be certain that all connections are secure and the conduit box cover is closed before electrical power is connected. Failure to follow these instructions could result in serious personal injury, death and/or property damage.

SYSTEM PREPARATION

Prior to pump start up, closed heating and cooling systems should be cleaned, drained and refilled with clean water. System ph must be maintained between 7 and 9.

STARTUP

⚠ CAUTION: SEAL DAMAGE HAZARD
Do not run pump dry, seal damage may occur. Failure to follow these instructions could result in property damage and/or moderate personal injury.

Do not start pump until the system has been filled and vented. Air should be vented from the system by means of an air vent located at a high point in the system, or by an alternate method. The system must be completely vented prior to pump operation. Do not run pumps dry. Pump operation without water circulation could result in pump and motor damage.

⚠ WARNING: HOT WATER LEAKAGE HAZARD
Pressurize the body slowly while checking for leaks at all joints with gaskets. Failure to follow these instructions could result in serious personal injury and/or property damage.

MODE OF DISCHARGE

The Series PL™ pump can be installed to discharge up or down, horizontally, left or right, but the motor shaft must remain in the horizontal position, the arrow on the body must point in the direction of flow and the conduit box must be positioned on the top of the motor housing (see figure 2).

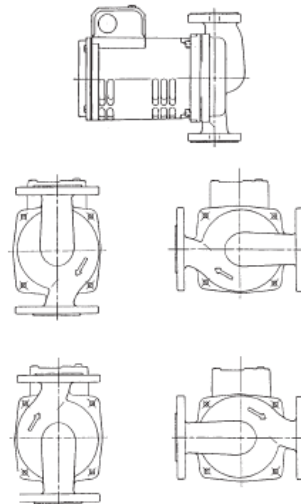

FIG. 2

PUMP BODY MAY BE ROTATED AS SHOWN, BUT CONDUIT BOX MUST REMAIN AT TOP.

TYPICAL WIRING INSTALLATION SCHEMATIC FOR 1Ø POWER SOURCE

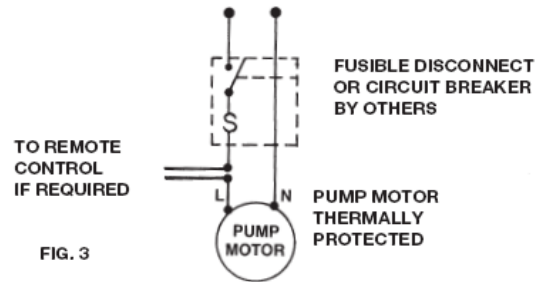

FIG. 3

CONDUIT BOX WIRING DETAIL

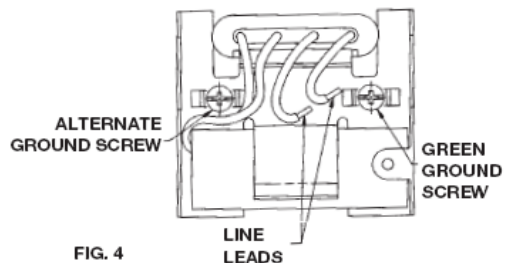

FIG. 4

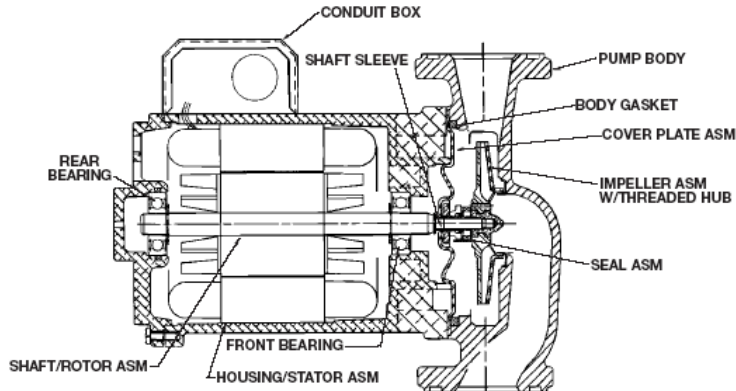

FIG. 5

INSTRUCTIONS FOR REPAIRING MECHANICAL SEAL

1. Follow steps 1 through 4 of section titled "REMOVAL OF PUMP FROM EXISTING SYSTEM FOR REPLACEMENT."
2. Loosen the four capscrews that hold the motor housing to the pump body. Remove these screws and remove the housing from the pump body.
3. Place the pump on a flat work surface and insert a screwdriver into one of the endplate ventilation slots until it engages one of the rotor cooling fins. While holding the rotor with the screwdriver, turn the impeller clockwise. Note that the impeller is molded around a metal hub with a left hand thread. Remove the impeller from the shaft.
4. Remove the seal assembly from the shaft by sliding it off the shaft sleeve.
5. Clean the seal seat with a clean rag and inspect for grooving or cracks. If it shows no grooving or cracks, it may be cleaned and reused.
6. If the seal seat is to be replaced, the face plate must be removed from the motor housing. Remove it by gently prying it away from the housing.
7. Remove the seal seat and cup. Lubricate the cup with soapy water and install new parts in the face plate recess.
8. Clean the shaft and sleeve before installing the new seal.
9. Slide the new carbon seal head onto the shaft sleeve until it contacts the seal seat. Slide the new "O-Ring" and back-up ring along the shaft sleeve until they fit inside the counter bore in the seal head. Place the seal spring between the back-up ring and the seal cage while positioning the seal cage flush with the end of the sleeve. Place the small end of the spring against the back-up ring. The three driving legs of the seal cage should engage the three slots on the seal head. While holding the rotor assembly with the screwdriver, thread the impeller onto the shaft in a counter clockwise direction. Tighten the impeller with light hand pressure. Take care to avoid bending a rotor cooling fin or damaging the shaft sleeve.
10. Clean the recess in the pump body and install a new body gasket.
11. Install the pump in the body and secure with four capscrews. Apply torque evenly in a criss cross pattern in 40 in-lb (4.52 N·m) increments to a torque of 80 in-lb (9.04 N·m).
12. Reinstall into the system using new flange gaskets. For instructions, see sections "PUMP INSTALLATION" and "WIRING INSTRUCTIONS" on pages 2 and 3.

PERIODIC INSPECTION

Bell & Gossett Booster Pumps are designed to provide years of trouble free service. It is recommended that periodic inspections be made to check for potential problems with the

pump. If any leakage or evidence of leakage is present repair or replace the unit.



Bell & Gossett

USA
 Bell & Gossett
 8200 N. Austin Avenue
 Morton Grove, IL 60053
 Phone: (847) 966-3700
 Facsimile: (847) 966-9052
<http://www.bellgossett.com>



INTL.
 Bell & Gossett / Export Dept.
 8200 N. Austin Avenue
 Morton Grove, IL 60053
 Phone: (847) 966-3700
 Facsimile: (847) 966-8366
<http://www.bellgossett.com>

CANADA
 Fluid Products Canada
 55 Royal Road
 Guelph, Ontario,
 N1H 1T1, Canada
 Phone: (519) 821-1900

© COPYRIGHT 1994, 2004 BY ITT INDUSTRIES, INC.
 PRINTED IN U.S.A. 1-04



NRF / NBF / SSF Circulator

Installation, Operation & Service Instructions

INSTALLER: PLEASE LEAVE THIS MANUAL FOR THE OWNER'S USE.

NOTE: Bell & Gossett recommends Bronze Booster Pumps be used for pumping potable water.



SAFETY INSTRUCTIONS

This safety alert symbol will be used in this manual and on the pump Safety Instruction decal to draw attention to safety related instructions. When used, the safety alert symbol means **ATTENTION! BECOME ALERT! YOUR SAFETY IS INVOLVED!** FAILURE TO FOLLOW THE INSTRUCTIONS MAY RESULT IN A SAFETY HAZARD.

Your NRF/NBF/SSF Booster Pump should have the warning/caution label displayed to the right (Fig. 1) on the pump conduit box. If this warning and caution label is missing or illegible, contact your local B&G Representative for a replacement.

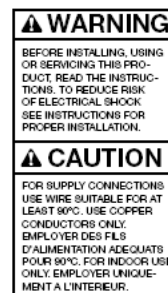

FIG. 1

Bell & Gossett



DESCRIPTION

The Model NRF/NBF/SSF Circulator Pump features system liquid lubricated bearings, non-overloading permanent split capacitor motor with impedance protection and quiet operation.

PUMP APPLICATION

The Model NRF/NBF/SSF Booster Pump may be used for water circulating applications in hydronic and solar systems.

OPERATIONAL LIMITS

These pumps are designed to pump liquids compatible with their iron or bronze body constructions.

Maximum Operating Pressure: 150 PSI (10 bars)

Maximum Operating Temperature:

NRF-22 & NRF-9F/LW, 240°F (115°C)
NBF Pumps (except NBF-33), 230°F (110°C)
NRF-33 & NBF-33, 225°F (107°C)
SSF Pumps, 230°F (110°C)

Electrical Rating: 115V, 60Hz, 1Ø; 220V, 60Hz, 1Ø;
220V, 50Hz, 1Ø; 230V, 60Hz, 1Ø

If your NBF pump is equipped with a sweat connected pump body, the maximum operating pressure is limited to 150 PSI (10 bars) or a lower value determined by the type of solder used and pressure/temperature limitations listed below:

Do not exceed these values.

(Solder type limits per ASTM STD. B16.18-1978)

PUMP BODY	TYPE OF SOLDER	MAXIMUM LIMITATIONS	
		PRESSURE PSI	TEMPERATURE °F
SWEAT	95-5	300	200
	TIN-	250	225
	ANTIMONY	200	250



WARNING:

Damage to the pump or failure of solder sealing joints may occur if these operational limits are exceeded. This can result in water leakage. Failure to follow this instruction could cause serious personal injury and/or property damage.

SAFETY REQUIREMENTS

MECHANICAL SAFETY



WARNING: EXCESSIVE SYSTEM PRESSURE HAZARD

The maximum working pressure of the pump is listed on the nameplate – DO NOT EXCEED THIS PRESSURE. Failure to follow these instructions could result in serious personal injury, death and/or property damage.



WARNING: EXCESSIVE PRESSURE HAZARD VOLUMETRIC EXPANSION

The heating of water and other fluids causes volumetric expansion. The associated forces may cause failure of system components and the release of high temperature fluids. This can be prevented by installing properly sized and located compression tanks and pressure relief valves. Failure to follow these instructions could result in serious personal injury, death and/or property damage.

THERMAL SAFETY



WARNING: EXTREME TEMPERATURE HAZARD

If the pump, motor or piping are operating at extremely high or low temperature, guarding or insulation is required. Failure to follow these instructions could result in serious personal injury, death and/or property damage.

ELECTRICAL SAFETY



WARNING: ELECTRICAL SHOCK HAZARD

Electrical connections are to be made by a qualified electrician in accordance with all applicable codes, ordinances and good practices. Failure to follow these instructions could result in serious personal injury, death and/or property damage.



WARNING: ELECTRICAL GROUNDING HAZARD

Adequate electrical grounding is required for the safe operation of B&G Pumps. The use of grounded metal conduit assures this requirement. If the means of connection to the supply – connection box (wiring compartment) is other than grounded metal conduit, ground the pump back to the service. Use a copper conductor at least the size of the circuit connectors supplying the pump. Connect the ground wire to the green grounding screw in the wiring compartment. Failure to follow these instructions could result in serious personal injury death and/or property damage.

This pump is for indoor use only.

REMOVAL OF PUMP FROM EXISTING SYSTEM FOR REPLACEMENT



WARNING: ELECTRICAL SHOCK HAZARD

Disconnect and lockout the power before servicing. Failure to follow these instructions could result in serious personal injury or death.

1. Close the valves on the suction and discharge sides of the pump. (If no valves have been installed, it may be necessary to drain the system.)



WARNING: HOT WATER HAZARD

Before draining the system, allow water to cool to at least 100°F, open the drain valve (take precautions against water damage) and leave the drain valve open until servicing is complete. Failure to follow these instructions could result in serious personal injury, death and/or property damage.



WARNING: ELECTRICAL SHOCK HAZARD

Be certain the electrical power is not present at the motor leads before continuing. Failure to follow these instructions could result in serious personal injury or death.

2. Loosen the conduit box cover screw and remove the cover.
3. Disconnect the electrical supply lines to the pump.



WARNING: HIGH PRESSURE HAZARD

Pressure may be present in the pump body. This pressure can be relieved by loosening the flange bolts and shifting the pump assembly slightly to allow the pressurized water to escape. Failure to follow these instructions could result in serious personal injury or death.

4. Remove the flange nuts and bolts or loosen the union ring nuts. Then remove the pump from the piping.

PUMP INSTALLATION

Locate the pump so there is sufficient room for inspection, maintenance and service. Bell & Gossett recommends the installation of service valves on the suction and discharge of all circulators to facilitate servicing or replacement of the circulator without draining the system.

CAUTION: The use of Teflon® impregnated pipe compound and Teflon® tape on pipe threads provides lubricity which can lead to overtightening and breakage. Do not overtighten. Failure to follow this instruction can result in moderate personal injury from hot water and/or property damage.

Install suction and discharge flanges or union connectors on the pipe ends. The use of Teflon® tape sealer or a high quality thread sealant is recommended.

Be sure to minimize any pipe-strain on the pump. Support the suction and discharge piping by the use of pipe hangers near the pump. Line up the vertical and horizontal piping so that the bolt-holes in the pump flanges match the bolt-holes in the pipe flanges. If union connections are used, line up the pump threads with union tail pieces. **DO NOT ATTEMPT TO SPRING THE SUCTION OR DISCHARGE LINES IN POSITION. THIS MAY RESULT IN UNWANTED STRESS IN THE PUMP BODY, FLANGE CONNECTIONS AND PIPING.** The code for Pressure Piping (ANSI B31.1) lists many types of supports available for various applications.

Bell & Gossett flange/union gaskets must be installed between the NRF/NBF/SSF pump body flanges and the suction and discharge pipe flanges/union tail pieces. Use 7/16" diameter x 1 1/2" long cap screw and matching nut to connect the pump to the flanges.

WARNING: HOT WATER HAZARD
When disassembling a gasketed joint, always use a new gasket upon reassembly. **NEVER RE-USE OLD GASKETS.** Failure to follow these instructions could result in serious personal injury, death and/or property damage.

Apply torque in even increments to both flange bolts until a value of 115 in-lbs. is reached. Both the suction and discharge flange bolts must be torqued in this manner.

If your NBF pump is equipped with a sweat connected pump body, see the following instructions:

1. Use a torch with a sharp pointed flame.
2. Clean tube ends and pump connections thoroughly.
3. Use 95-5 (Tin-Antimony); 50-50 or 60-40 (Tin-Lead) solders only, and a good grade of flux.

CAUTION:
Heat associated with the use of silver solder may damage a pump voiding the warranty. Do not use silver solder. Failure to follow these instructions could result in property damage and/or moderate personal injury.

CAUTION:
Excessive use of solder in a vertical installation may result in damage to the pump impeller. Do not use excessive flux. Failure to follow these instructions could result in property damage and/or moderate personal injury.

4. When sweating the joints, first wrap the pump body with a cool wet rag, then direct the flame with care to avoid subjecting the pump to excessive heat.
5. Check soldered connections for leaks. If resoldering is required, take care to avoid subjecting the pump to excessive heat.

WARNING: WATER LEAKAGE HAZARD
To prevent leakage, make certain that the flange bolts or ring nuts have been adequately tightened and that the solder connections do not leak. Failure to follow these instructions could result in serious personal injury, death and/or property damage.

MODE OF DISCHARGE

The Model NRF/NBF/SSF Circulator can be installed to discharge up or down, horizontally, left or right, but the motor shaft must remain in the horizontal position, the arrow on the body must point in the direction of the flow, the conduit box must be positioned on the top or to the side of the motor housing (see figure 2). If the conduit box position must be changed, it is best to do so before installation. However, if the pump is already installed, see the section titled "REMOVAL OF PUMP FROM EXISTING SYSTEM FOR REPLACEMENT" before proceeding.

TO CHANGE THE CONDUIT POSITION

1. Remove the four (4) 1/4"-20 Allen screws (9/16" wrench) while supporting the motor assembly.
2. Remove the motor assembly from the pump body and rotate it to the desired position (see figure 2).
3. Replace the Allen screws and tighten evenly in a diagonal method to 60 in-lbs.
4. Check to see that the impeller turns freely. Insert your finger in the discharge port of the pump body (the arrow on the pump body points in the direction of the discharge) until you can feel the impeller and rotate it with your fingertip. If the impeller does not turn easily, repeat the disassembly/reassembly process.

*Teflon® is a registered trademark of E.I. DuPont de Nemours and Company.

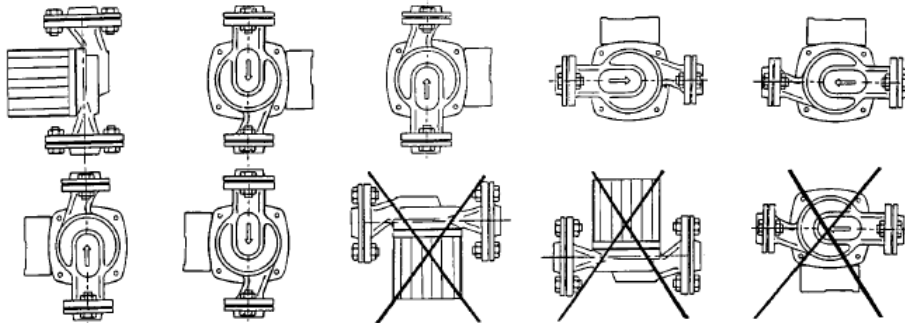

FIG. 2

**WARNING: ELECTRICAL SHOCK HAZARD**

Disconnect and lock out the power before making electrical connections. Failure to follow these instructions could result in serious personal injury or death.

WIRING INSTRUCTIONS

- Loosen the screw securing the conduit box cover (wiring compartment), and remove the screw & cover.
- Attach the appropriate size connector to the hole in the side of the conduit box.
- Using a minimum size of 14 AWG copper electrical wire (refer to your local code for wiring restrictions), wire the motor to a single phase power source that matches the electrical rating on the pump nameplate. See Fig. 3. Use the size of electrical wire as dictated by local code.
- Connect the ground wire to the inside of the conduit box with one of the green screws provided inside the box. See Fig. 4.

NOTE: Electrical supply and grounding wires must be suitable for at least 90°C (194°F).

NOTE: Model NRF/NBF/SSF Circulators are impedance protected and do not require external overload protection.

**WARNING: ELECTRICAL SHOCK HAZARD**

Be certain that all connections are secure and the conduit box cover is closed before electrical power is connected. Failure to follow these instructions could result in serious personal injury, death and/or property damage.

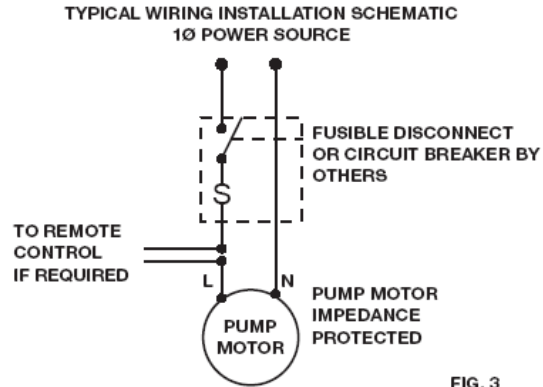
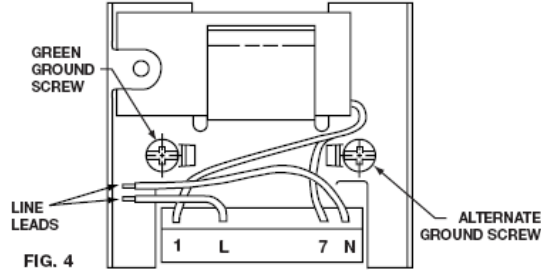
**CONDUIT BOX WIRING DETAIL****SYSTEM PREPARATION**

Prior to pump start-up, closed heating and cooling systems should be cleaned, drained, and refilled with clean water. The system fluid pH must be maintained between 7 and 9.

START-UP

Do not start pump until the system has been filled and vented. Air should be vented from the system by means of an air vent located at a high point in the system. The system must be completely vented prior to pump operation. Do not run NRF/NBF/SSF circulators dry. Pump operation without water circulation could result in pump and motor damage.

**WARNING: HOT WATER LEAKAGE HAZARD**

Pressurize the body slowly while checking for leaks at all joints with gaskets or solder connections. Failure to follow these instructions could result in serious personal injury and/or property damage.

PERIODIC INSPECTION

Bell & Gossett NRF/NBF/SSF Circulators are designed to provide years of trouble free service. It is recommended that periodic inspections be made to check for potential problems with the pump. If any leakage or evidence of leakage is present, repair or replace the unit.



ITT Industries

Bell & Gossett

USA
Bell & Gossett
8200 N. Austin Avenue
Morton Grove, IL 60053
Phone: (847) 966-3700
Facsimile: (847) 966-9052
<http://www.bellgosset.com>



INTL.
Bell & Gossett / Export Dept.
8200 N. Austin Avenue
Morton Grove, IL 60053
Phone: (847) 966-3700
Facsimile: (847) 966-8366
<http://www.bellgosset.com>

CANADA
Fluid Products Canada
55 Royal Road
Guelph, Ontario,
N1H 1T1, Canada
Phone: (519) 821-1900
www.ittpc.ca

© COPYRIGHT 1996, 2004 BY ITT INDUSTRIES, INC.
PRINTED IN U.S.A. 1-04

L8148A,E,J Aquastat® Relays

PRODUCT DATA

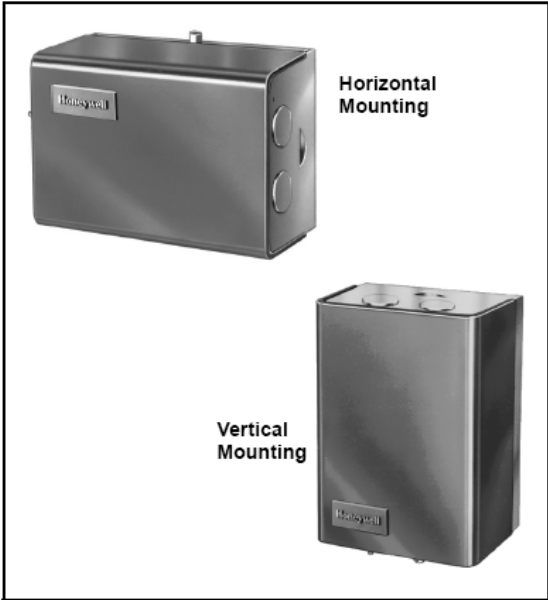

APPLICATION

The L8148 Aquastat® Relays are immersion type hydronic controllers that combine high limit protection with switching relay control of burner and circulator motors.

FEATURES

- All models are used with a 24 Vac thermostat.
- Models include special terminals for adding remote, low limit temperature control.
- L8148E,J have terminals for adding zone valve system wiring.
- L8148E models are available with plug for connecting Aquastat® Relay directly to D892/M892 Vent Dampers.
- All devices include transformer to provide power for the low voltage control circuit. Different models provide switching of line, low, or millivoltage burner circuit.
- Case available for horizontal or vertical mounting.
- Combinations of two insulation and two insertion well lengths are available.

Contents

Application	1
Features	1
Specifications	2
Ordering Information	2
Installation	4
Setting and Adjustments	12
Operation	12
Checkout	12



SPECIFICATIONS

IMPORTANT

The specifications given in this publication do not include normal manufacturing tolerances. Therefore, this unit may not exactly match the listed specifications. Also, this product is tested and calibrated under closely controlled conditions, and some minor differences in performance can be expected if those conditions are changed.

TRADELINE® Models

TRADELINE® models are selected and packaged for ease of handling, ease of stocking, and maximum replacement value. TRADELINE® model specifications are the same as those of standard models except as noted below.

TRADELINE® Models Available:

- L8148A Aquastat® Relay, without zone control terminals, without well and spud. See Fig. 2.
- L8148E Aquastat® Relay with Molex® plug for use with D892/M892 Vent Dampers; 180°F to 240°F (82°C to 116°C) scale range; without well and spud.
- L8148J Aquastat® Relay with zone control terminals; without well and spud. See Fig. 3.

Scale Range: 140°F to 240°F (60°C to 116°C).

Additional Features:

- Heat-conductive compound for better bulb response in oversized well. For more information on heat-conductive compound, see Material Safety Data Sheet (MSDS), form 69-0955.
- Case can be vertically or horizontally mounted.
- High-limit dial stop is factory-set at end of high-limit scale; can be adjusted.
- TRADELINE® pack with cross reference label and special instructions.

Standard Models

Models: See Table 2.

Electrical Ratings:

Table 1. Circulator Control Circuit (Amperes).

Type	120 Vac	240 Vac
Full Load	7.4	3.7
Locked Rotor	44.4	22.7

Voltage and Frequency: 120 Vac, 60 Hz.

Burner Control Circuits:

Line Voltage: Ratings same as for circulator above.

Low Voltage: 0.8A maximum at 24 Vac.

Millivoltage: 0.25A at 1/4 to 12 Vdc.

Approvals:

Underwriters Laboratories Inc. Listed: File No. MP466, Guide No. MBPR (models with well); Guide No. MBPR2 (models without well).

Canadian Standards Association Certified: File No. LR1620, Guide No. 400-E-O.

ANSI Miswiring: Models with 1/4 in. tab terminal meet ANSI Appliance Miswiring Standard.

Immersion Well Dimensions:

Brass Spud for Boiler Fitting: 1/2 or 3/4 NPT.

Insulation Depth: 1-1/2 or 3 in. (38 or 76 mm).

NOTE: Not all models include wells. If well is not included but is needed, refer to form 68-0040 to order.

Insertion Length: 3-3/8 in. (86 mm).

Maximum Pressure On Immersion Well:

255 psi (1758 kPa).

Maximum Bulb Temperature:

40°F higher than setpoint, or up to 265°F (23°C higher than setpoint, or up to 129°C).

Material Safety Data Sheets (MSDS): For more information on heat-conductive compound, see form 69-0955.

Maximum Ambient Temperature:

150°F (66°C) with 1.2A, 24V load.
77°F (25°C) with 1.4A, 24V load.

ORDERING INFORMATION

When purchasing replacement and modernization products from your TRADELINE® wholesaler or distributor, refer to the TRADELINE® Catalog or price sheets for complete ordering number.

If you have additional questions, need further information, or would like to comment on our products or services, please write or phone:

1. Your local Home and Building Control Sales Office (check white pages of your phone directory).
2. Home and Building Control Customer Relations
Honeywell, 1885 Douglas Drive North
Minneapolis, Minnesota 55422-4386

In Canada—Honeywell Limited/Honeywell Limitée, 35 Dynamic Drive, Scarborough, Ontario M1V 4Z9.

International Sales and Service Offices in all principal cities of the world. Manufacturing in Australia, Canada, Finland, France, Germany, Japan, Mexico, Netherlands, Spain, Taiwan, United Kingdom, U.S.A.

Table 2. Standard L8148 Model Specifications.

Model Number	Burner Circuit Voltage	Mounting Case ^a	Special Provision for Adding Remote Low Limit	High Limit	Second Limit	Circulator Control	Maximum Number of Zone Controls		Thermostat Required	Manual/ Auto Switch
							Valves ^b	Relays ^c		
L8148A	Line	Horizontal	Yes	Yes	No	Can be added remotely	—	—	24V	No
L8148E ^{d,e}	Low	Vertical					2	4		
L8148J	Low or millivolt	Vertical or horizontal					—	—		

^a See Fig. 1 for case dimensions.

^b Number of V8043 Zone Valves that can be powered from the L8148 without additional transformer(s). 1.2A load is the maximum permissible when ambient temperature exceeds 77°F (25°C).

^c Number of R8230C Relays that can be powered from the L8148. Additional relays in groups of four or fewer require an additional transformer.

^d Models available with plug for connecting L8148E directly to the D892/M892 Vent Dampers.

^e Models available with plug (L8148E) and 50 VA transformer are for use with the Honeywell SV9500/SV9600 SmartValve® System Control. No zone valves or relays can be powered from the L8148 when used with SV9500/SV9600 gas valves.

Maximum Ambient Temperature:

150°F (66°C) with 1.2A 24V load;
77°F (25°C) with 1.4A 24V load.

Thermostat Heat Anticipator Setting: 0.2A.

Standard Scale Range: 180°F to 240°F (82°C to 116°C).

Differential: Nonadjustable.

Finish: Gray enamel.

Optional Specifications:

Scale Range: 140°F to 240°F (60°C to 116°C).
High Limit Dial Stop.

Case Dimensions: See Fig. 1.

Accessories:

- 107408 Heat Conductive Compound (4 oz. can). For more information, see form 69-0955, Heat Conductive Compound.
- 124904 Well Adapter. For ordering information, see form 68-0040, Immersion Wells and Compression Fittings.

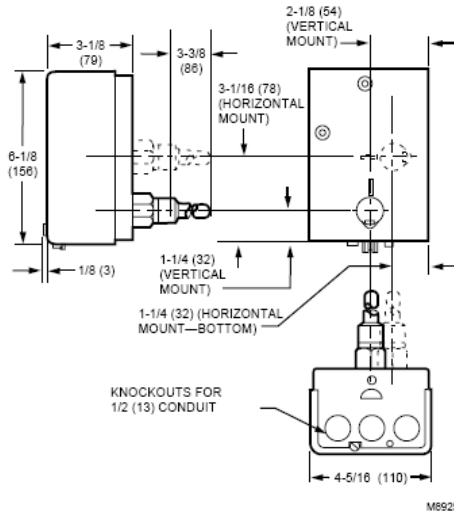
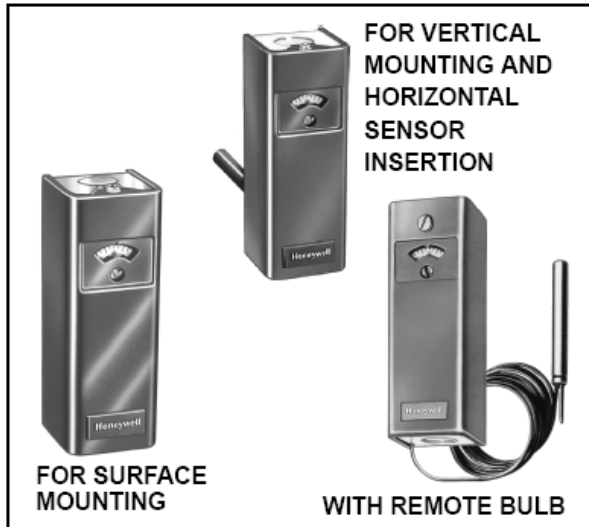

Fig. 1. L8148 dimensions in in. (mm).

L4006,7,8; L6006,7,8 Aquastat® Controllers

PRODUCT DATA



FEATURES

- L4006,7 and 8 provide spst switching for high or low limit or circulator control.
- L4006G includes two spst switches that provide high limit and circulator control.
- L4006,7; L6006,7 models are available for insertion in vertical or horizontal immersion well, vertical or horizontal direct immersion, and surface mounting.
- L4008, L6008 include remote bulb for mounting controller at a location away from the sensing element.
- Totally enclosed Micro Switch[®] snap-acting switches operate on temperature rise to set point.
- Models calibrated for high limit use are also suitable for low limit control if a separate high limit controller is used.
- Visible control point scale and external adjustment screw permit easy setting.
- Remote bulb models may be used to sense air temperature in ducts and in outside air sensing applications.

GENERAL

Aquastat® Controllers are immersion type devices for limiting or regulating the temperature of liquids in boilers, storage tanks, and other applications where temperature control is required.

Contents

General	1
Features	1
Specifications	2
Ordering Information	2
Installation	8
Operation	15
Adjustments	16
Checkout	17
Material Safety Data Sheet	18

© U.S. Registered Trademark
Copyright © 2001 Honeywell • All Rights Reserved



60-2104-9

SPECIFICATIONS

IMPORTANT

The specifications given in this publication do not include normal manufacturing tolerances. Therefore, this unit may not exactly match the listed specifications. Also, this product is tested and calibrated under closely controlled conditions, and some minor differences in performance can be expected if those conditions are changed.

SUPER TRADELINE®/TRADELINE® MODELS

SUPER TRADELINE controls offer features not available on TRADELINE or standard models, and are designed to replace a wide range of Honeywell and competitive controls.

TRADELINE models are selected and packaged to provide ease of stocking, ease of handling, and maximum replacement value. Specifications of SUPER TRADELINE and TRADELINE controls are the same as those of standard models except as noted below.

SUPER TRADELINE Model: L6006A Aquastat Controller.

SUPER TRADELINE Features:

SUPER TRADELINE package with cross reference label and special instructions.

Factory-set stop at 240°F (116°C).

Vertical or horizontal mount.

Tube of heat-conductive compound.

Insulation: 1-1/2 to 3 in. (38 to 76 mm).

TRADELINE Models: L4006A,B,E; L4008E; L6006C; L6008A Aquastat Controllers.

TRADELINE Features Available:

TRADELINE package with cross reference label and special instructions.

Some Tradeline models include well.

Factory-set stops at 180°F, 240°F, or 250°F (82°C, 116°C, or 121°C).

Vertical or horizontal mount.

Tube of heat-conductive compound.

Insulation depths of 1-1/2 or 3 in. (38 or 76 mm).

NOTE: The following specifications are standard. Variances, available as options, are listed in Tables 1 and 2.

Electrical Ratings (A):

Models with 2°F (1°C) fixed differential:

	120 Vac	240 Vac
Full Load	2.6	1.3
Locked Rotor	15.6	7.8

Models with 5°F (3°C) fixed differential or 5°F to 30°F (3°C to 17°C) adjustable differential:

	110/120 Vac	200/240 Vac	277 Vac ^a
Full Load	8.0	5.1	4.2
Locked Rotor	48.0	30.6	25.2
Millivoltage	0.25 at 0.25 to 12 Vdc		

^a L6008G only.

Switching:

L4006, L4007, L4008: Spst.

L6006, L6007, L6008: Spdt (breaks R-B and makes R-W on temperature rise at setpoint).

ORDERING INFORMATION

When purchasing replacement and modernization products from your TRADELINE® wholesaler or distributor, refer to the TRADELINE® Catalog or price sheets for complete ordering number.

If you have additional questions, need further information, or would like to comment on our products or services, please write or phone:

1. Your local Home and Building Control Sales Office (check white pages of your phone directory).
2. Home and Building Control Customer Relations
Honeywell, 1885 Douglas Drive North
Minneapolis, Minnesota 55422-4386

In Canada—Honeywell Limited/Honeywell Limitée, 35 Dynamic Drive, Scarborough, Ontario M1V 4Z9.
International Sales and Service Offices in all principal cities of the world. Manufacturing in Australia, Canada, Finland, France, Germany, Japan, Mexico, Netherlands, Spain, Taiwan, United Kingdom, U.S.A.

Pressure Rating:

Capillary Bulb (Direct Immersion): 200 psi (1379 kPa).
 Immersion Well: 255 psi (1758 kPa).

Sensing Bulb Material: Copper.

Sensing Bulb Fill: Liquid—toluene or silicone oil.

Sensing Bulb Dimensions: 2-7/8 in. (73 mm) long,
 3/8 in. (10 mm) diameter.

Wiring: Screw terminals.

Maximum Ambient Temperature: 150°F (66°C).

Approvals:

Underwriters Laboratories Inc:
 Remote bulb devices and well-mounted devices shipped without well are component recognized:
 File No. MP466, Guide No. MBPR2.
 L4006A shipped with well, L4006G, L4007A,B; L6006C for surface mounting, L6006B for direct immersion mounting, and L6007A are listed: File No. MP466, Guide No. MBPR. L6008G is listed: File No. E4436, Guide No. XAPX.
 Canadian Standards Association: File No. LR1620, Guide No. 400-E-O.

ANSI Miswiring: Models with 1/4 in. tab terminal meet ANSI Appliance Miswiring Standard.

Mounting:

Horizontal and vertical models mount directly to an immersion well installed in a boiler fitting. L4006H and L6006C contain bracket and clamp for surface mounting on pipe or tank. Remote bulb models have three mounting holes in rear of case for screw mounting to a vertical surface. The L6006B direct immersion model also mounts directly to a boiler fitting.

Finish: Gray.

Dimensions:

Installation: See Fig. 1, 2, and 3.
 Immersion Well: See Fig. 4.
 Boiler Fitting and Bulb: See Fig. 5.

Accessories and Parts:

137536A Scale Lock Assembly: Includes one 137536-767 Scale Lock and one 80844C-767 Screw, No. 3-48 x 3/16.
 Q615A1004 Weatherproof Enclosure (for remote bulb devices only).
 107408 Heat-Conductive Compound (4-oz. can).
 104488 Spring Clip (stainless steel).
 124904 Well Adapter.
 Immersion Well Assemblies and Compression Fittings: See form 68-0040, Wells and Fittings for Temperature Controllers, for list and ordering information.

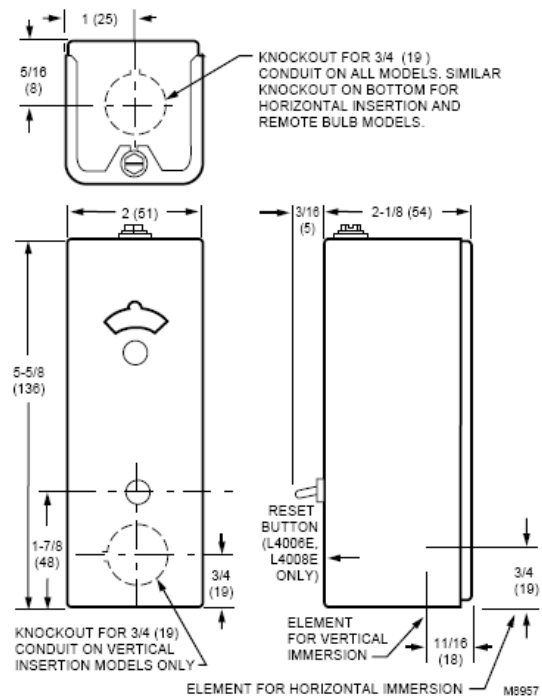

Fig. 1. Approximate case installation dimensions in in. (mm) for direct insertion models.

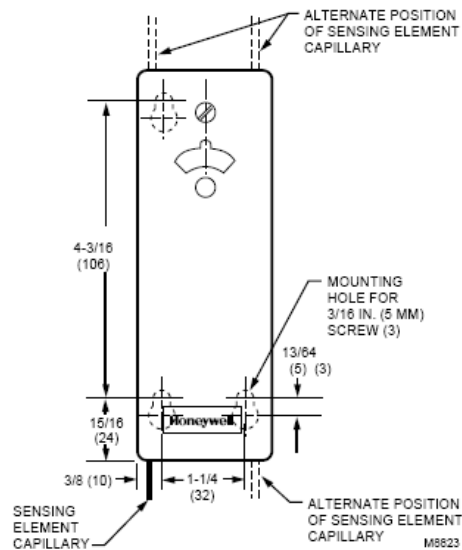

Fig. 2. Approximate installation dimensions in in. (mm) for remote bulb models. Other dimensions are the same as Fig. 1.

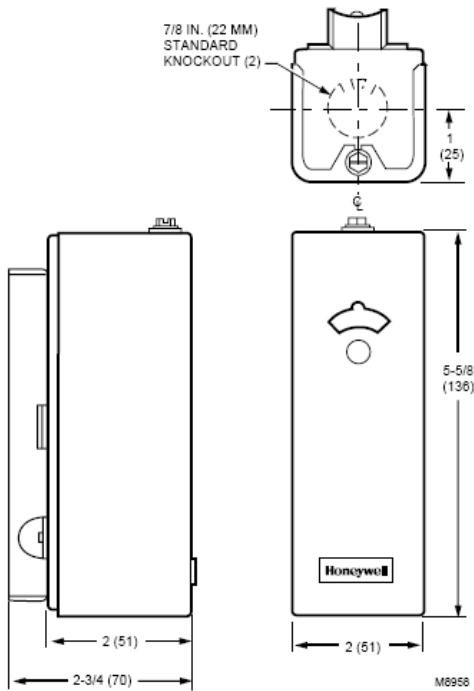

Fig. 3. Approximate installation dimensions in in. (mm) for surface mount models.

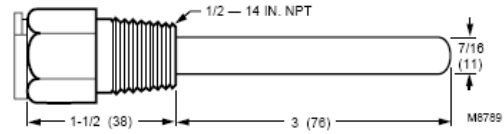

Fig. 4. Approximate immersion well dimensions in in. (mm) for all models except L4006C and L6006B.

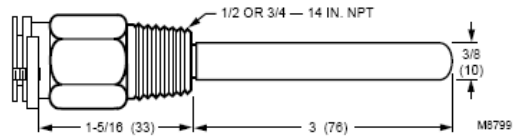

Fig. 5. Approximate boiler fitting and bulb dimensions in in. (mm) for L4006C and L6006B.

Standard Models:

L

Table 1. L4006, L4007, L4008 Controller (Spst Switching) Specifications.

Model	Application	Range °F (°C)	Midscale Differential °F (°C)	Insertion ^a	Switching On Temperature Rise	Available Options
L4006A	High or low limit	40° to 180° (4° to 82°) or 100° to 240° (38° to 116°)	2° or 5° fixed (1° or 3°) or 5° to 30° adjustable (3° to 17°)	Horizontal	Breaks	<ul style="list-style-type: none"> — TRADELINE models available. — NPT brass spud 1/2 or 3/4 in. — Special capillary assembly. — Insertion 3-3/8 or 5 in. (86 or 127 mm) — Celsius scale markings. — Factory-set stops at 160°, 180°, 185°, 200°, 220°, or 230°F (71°, 82°, 85°, 93°, 104°, or 110°C). — Insulation depths of 1-1/2, 3 or 4 in. (38, 76, or 102 mm). — Screw and mounting brackets. — Plastic tubing over well. — Modified dial with stop. — Special cover and knobs. — With ground screw.
L4006B	Circulator	100° to 240°F (38° to 116°C)L	5°F (3°C) fixed or 5° to 30°F (3° to 17°C) adjustable	Horizontal	Makes	<ul style="list-style-type: none"> — TRADELINE model available. — Insulation depth 1-1/2 or 3 in. (38 or 76 mm). — NPT brass spud 3/4 in. — Screw in front of case on dial suitable for Powerpile® control. — Factory-set stop at 240°F (116°C).
L4006C	High or low limit	65° to 200°F (18° to 93°C)	3-1/2°F (2°C) fixed	Horizontal direct immersion	Breaks	<ul style="list-style-type: none"> — TRADELINE model available. — Less cover. — Capillary 10 in. (254 mm). — NPT brass spud 3/4 in.
L4006E ^b	High limit	130° to 290°F (54° to 141°C)	Manual reset	Horizontal or vertical	Breaks	<ul style="list-style-type: none"> — TRADELINE model available. — Insulation depth 1-1/2 or 3 in. (38 or 76 mm). — NPT brass spud 1/2 in. — Factory-set stop at 250°F (121°C). — Capillary 8 in. (203 mm).
L4006G	High limit and circulator control	100° to 200°F (38° to 93°C)	10°F (6°C) fixed	Horizontal	Two switches break simultaneously	<ul style="list-style-type: none"> — External adjustment knob. — Insulation depth 4 in. (102 mm). — Factory-set stop at 160°F (71°C). — Celsius scale markings. — Without well.

INSTALLATION

When Installing This Product...

1. Read these instructions carefully. Failure to follow them could damage the product or cause a hazardous condition.
2. Check the ratings given in the instructions and on the product to make sure the product is suitable for your application.
3. Installer must be a trained, experienced service technician.
4. After installation is complete, check out product operation as provided in these instructions.

WARNING

Explosion Hazard.
Can cause serious injury, death or property damage.
This product is intended for use only in systems with a pressure relief valve.

WARNING

Electrical Shock Hazard.
Can cause serious injury or death.
Disconnect power supply before beginning installation to prevent electrical shock or equipment damage.

CAUTION

Equipment Damage Hazard.
Use of incorrect device or improper installation can damage the system.

1. Do not replace immersion-type Aquastat Controller with strap-on Aquastat Controller.
2. Do not secure draw nut so tightly that retainer clamp can collapse tubing.

IMPORTANT

1. Terminals on these Aquastat relays are approved for copper wire only.
2. Controller may be used with or without immersion well. If used, well must snugly fit sensing bulb for best thermal response. Insert bulb until it rests against the bottom of the well. Use well of correct length and bend the tubing, if necessary, to provide enough force to hold the bulb against the bottom of the well. Avoid making a sharp bend in the tubing that it can produce a break in the tubing and cause loss of fill. This condition causes the high and low limit controls to be made continuously.
3. If well does not snugly fit on bulb, use the heat-conductive compound, included with Super Tradeline and Tradeline models, as follows: Fold the plastic bag of compound lengthwise and twist gently. Snip the end of the bag and insert into the well. Slowly pull out the bag while squeezing firmly to distribute compound evenly in the well. Insert the bulb into the well. Bend the tubing, if necessary, to provide force to hold the bulb against the bottom of the well and to hold the outer end of the bulb firmly in contact with the side of the well. Wipe off excess compound.

The manufacturer usually provides a tapping for insertion of the controller sensing element. This tapping is located at a point where typical water temperature can be measured. Depending on the model, the element is inserted in an immersion well, through a boiler fitting, or directly immersed.

Installation should be made by a qualified service technician. Follow the instructions furnished by the system manufacturer, if available. Otherwise, refer to appropriate procedure listed below.

Mounting Immersion Well and Direct Immersion Models (L4006A,B,C,E,G; L4007A,B; L6006A,B; L6007A)

Installing Immersion Well Models (L4006A,B,E,G; L4007A,B; L6006A; L6007A)

On an existing installation, shut off the power and remove the old control. If the old immersion well appears suitable, and if the adapter clamp on the Aquastat Controller fits the old well spud, this well does not need to be replaced.

To replace the well:

1. If the system is filled, drain the system to a point below the boiler tapping.
2. Remove the old well from the boiler tapping.
3. Install the immersion well included with the controller. If the boiler tapping is greater than 1/2 in., use a reduction fitting to adapt the boiler opening to the 1/2 in. threads that are standard with the well or fitting. Fittings with 3/4 in. threads are also available.
4. Fill the system. Make sure that the well is screwed in tightly enough to prevent leakage. Do not use the case as a handle to tighten the well after the controller is secured to the well.

To install the controller:

1. Loosen the screw (at the top of the case, above the scale setting), and remove the cover. Loosen the two screws that secure the adapter clamp (Fig. 6).
2. Insert the sensing element into the immersion well.
3. Fasten the case of the Aquastat Controller to the well with the adapter clamp. Make certain that the clamp is properly positioned over the groove of the well spud. Also, be sure the flange at the opening of the well fits snugly into the opening of the case. The sensing bulb must bottom in the well.

NOTE: Some models include up to 3 in. (76 mm) extra capillary tubing inside the case. In these models, pull out that extra tubing, if needed.

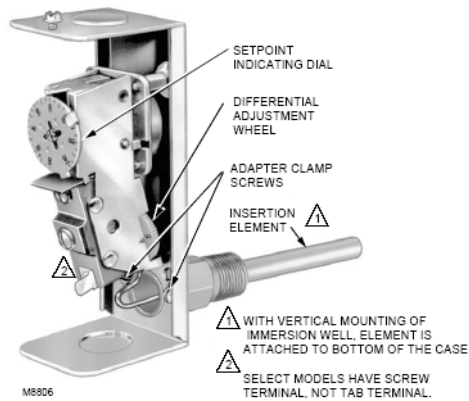

Fig. 6. Internal view of L6006A.

Installing Direct Immersion Models (L4006C, L6006B)

Models that provide for direct immersion of the sensing element into the boiler include a bulb compression fitting assembly instead of an immersion well. Install the fitting in the boiler tapping as follows:

1. Be sure the sealing washer is in place as shown in Fig. 7. Make sure that the spud of the bulb compression fitting is screwed in tightly enough to prevent leaking.

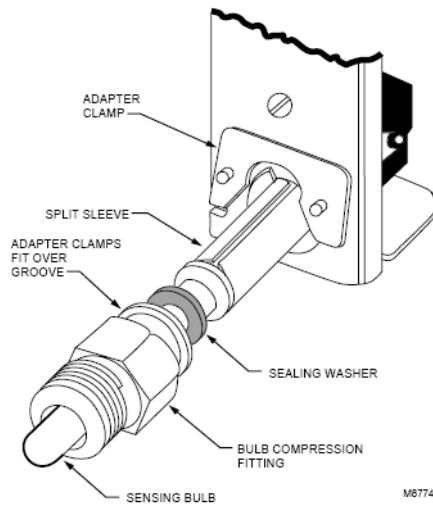

Fig. 7. Direct immersion model with fitting partially removed.

2. Insert the immersion sensing bulb through the bulb compression fitting. Adjust the adapter clamp so that it fits over the groove at the opening of the bulb compression fitting.
3. Tighten the adapter clamp screws so that the Aquastat Controller is firmly attached to the bulb compression fitting.

Mounting Remote Bulb Models (L4008A,B,E; L6008A,G,H)

The remote temperature-sensing bulb can either be installed in an immersion well (Fig. 8) that extends into the boiler or tank, or it can be directly immersed in the controlled medium. See Fig. 9. For installations that do not use a well, secure the remote bulb with a bulb compression fitting (Fig. 10), or capillary compression fitting (Fig. 11).

Order well, well adapter, bulb compression fitting or capillary compression fitting separately. See form 68-0040, Wells and Fittings for Temperature Controllers. If used, well must snugly fit sensing bulb for the best thermal response. Insert bulb until it rests against the bottom of the well. Hold it there while tightening the tubing clamp. See Fig. 8.

The boiler manufacturer usually provides a tapping for the insertion of the Aquastat Controller sensing element. This tapping should be located at a point where typical water temperature can be measured. Never locate the bulb or protecting immersion well close to a hot or cold water inlet or a steam coil.

If the system is filled, drain system to a point below the boiler tapping, or wherever the sensing bulb is to be installed.

The bulb can also be installed in the supply line of an indirect water heater, in the direct water heater itself, or in the feed riser, about 6 in. (153 mm) above the boiler. If the riser is valved, the bulb can be installed between the boiler and the valve.

NOTE: Do not make sharp bends or kinks in the capillary. Make bends no sharper than 1 in. (25 mm) radius.

After installing the controller, carefully coil the excess capillary at the bottom of the controller case.

Mounting Immersion Well

1. Screw the well into the boiler, tank, or pipe tapping.
2. Insert the bulb in the well, pushing the tubing until the bulb bottoms in the well.
3. Attach the retainer clamp to the end of the well spud. Loosen the draw nut and spread the jaws of the clamp with the screwdriver if necessary. See Fig. 8.
4. With the retainer clamp attached to the well spud (be sure the jaws of the clamp hook over the ridge at the end of the spud, as shown at points A in Fig. 8), adjust the tubing to fit through the retainer clamp groove, as shown at point B (Fig. 8).
5. Tighten the draw nut so that the retainer clamp is firmly attached to the well spud and the tubing is held securely in place.

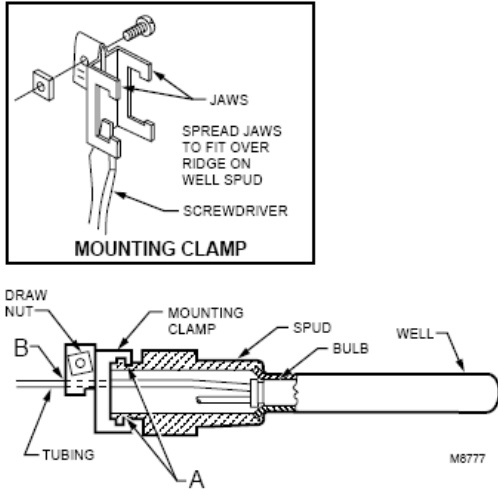

Fig. 8. Immersion well fitting.

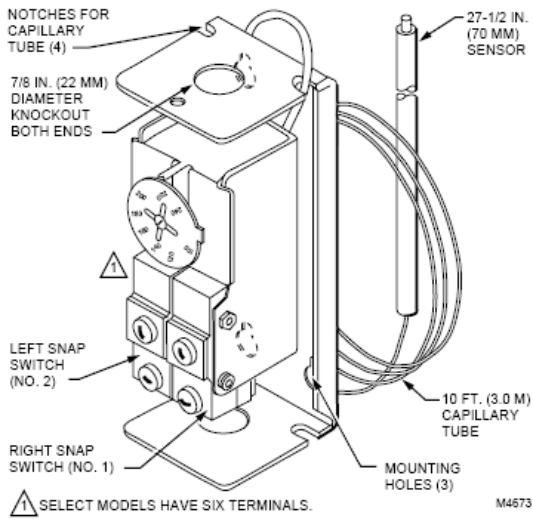

Fig. 9. Internal view of L4008L or L6008G.

Mounting With Bulb Compression Fitting

1. Screw the fitting into the boiler or pipe tapping.
2. Slide the sealing washer onto the bulb.
3. Insert the bulb into the fitting until the bulb bottoms.
4. Slide the split sleeve into the fitting. See Fig. 10.

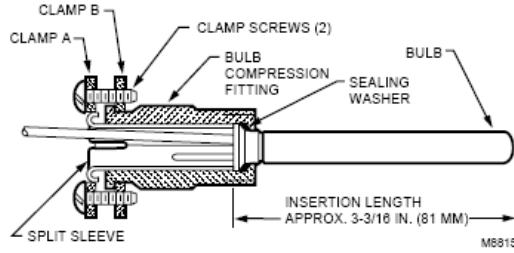

Fig. 10. Bulb compression fitting. Use with L4006A,B; L6008A.

5. Place clamps A and B on the assembly so that the sleeve is drawn into the fitting when the screws are tightened.

NOTE: Make sure that the nub on clamp A engages space between the sleeve and the clamp.

6. Tighten the clamp screws evenly.

Mounting With Capillary Compression Fitting

1. Screw the fitting into the boiler or pipe tapping.
2. Place the packing nut on the tubing.
3. Slide the bulb completely through the fitting.
4. Place the composition disk and four slotted brass washers on the tubing in the order shown in Fig. 11. Turn the brass washers so the slots are 180 degrees apart.

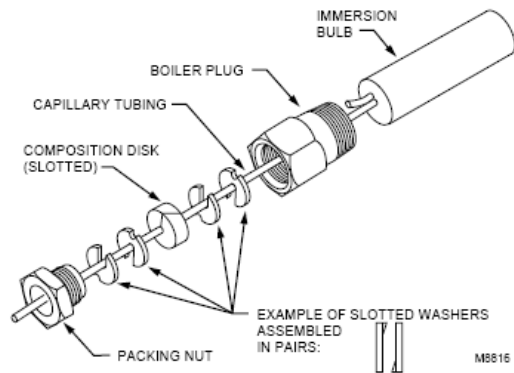

Fig. 11. Capillary compression fitting. Use with L4008.

5. Slide the seal assembly into the fitting and tighten the packing nut.

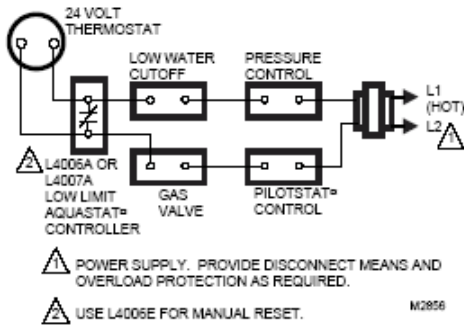

Fig. 19. Typical gas-fired system with domestic hot water.

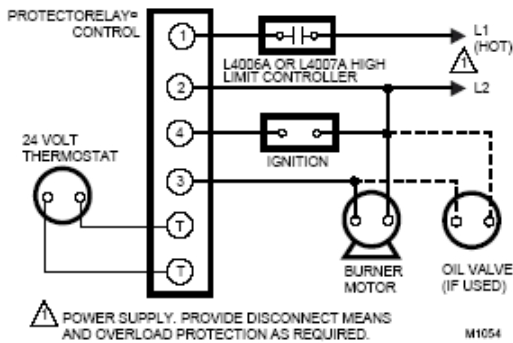

Fig. 20. Typical oil-fired gravity system.

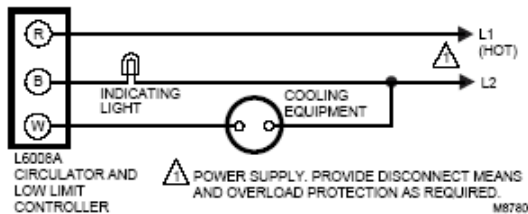

Fig. 21. L6008A used to control cooling equipment and indicating light.

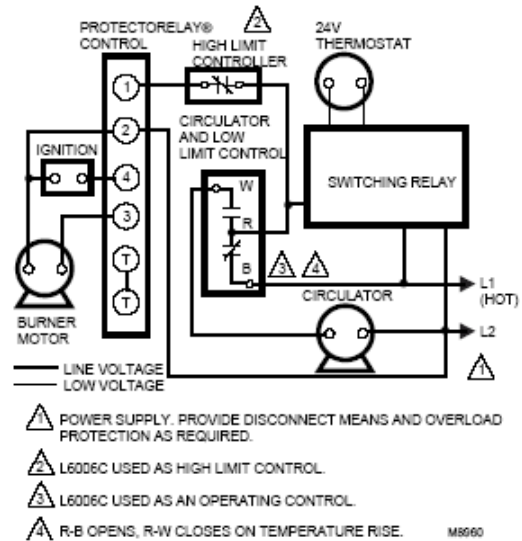

Fig. 22. Typical oil-fired hydronic system with domestic hot water.

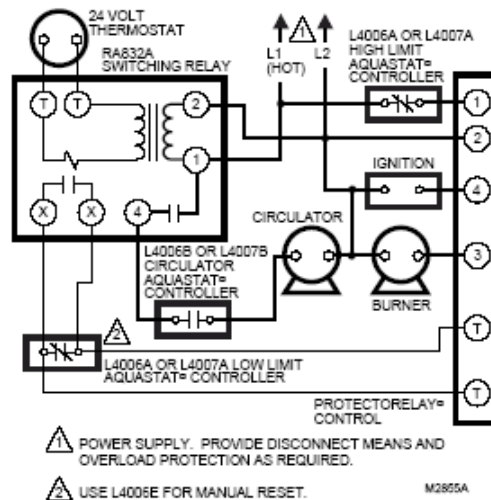

Fig. 23. Typical oil-fired hydronic heating system that provides year-round domestic hot water using RA832A.

ADJUSTMENTS

Adjusting Differential

Set the differential to correspond with the boiler manufacturer recommendations. To adjust models with adjustable differential, rotate the wheel on the back of the snap switch, see Fig. 32, until the desired reading is aligned with the V notch in the frame. The wheel provides an adjustment from 5°F to 30°F (3°C to 17°C). Replace the cover on the Aquastat Controller.

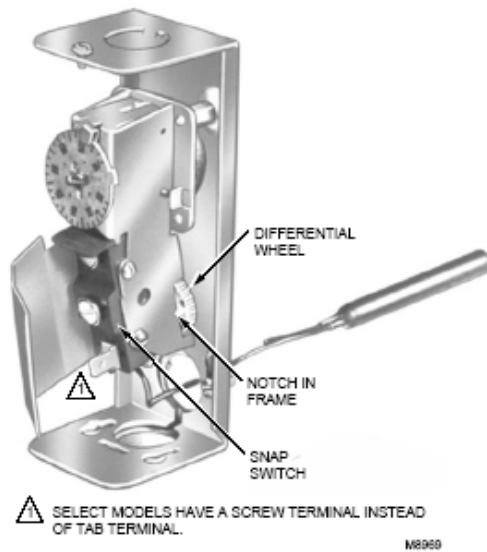

Fig. 31. Adjusting the differential.

Adjust the control point to correspond with the boiler manufacturer recommendations. To adjust, insert a screwdriver in the slotted screw type head located beneath the window in the cover. Turn the scale to the desired control point.

Adjusting L6008G Interstage Differential

The L6008G Controller has an adjustable interstage differential. The set point adjustment knob determines the temperature at which the right switch operates. The left switch can be adjusted to operate from 3°F to 10°F (1.7°C to 5.6°C) above the point of operation of the right switch. See Fig. 30 for the operation of the L6008G. The interstage differential is adjusted by turning the star wheel with a narrow screwdriver inserted into the rectangular hole in the chassis (Fig. 33).

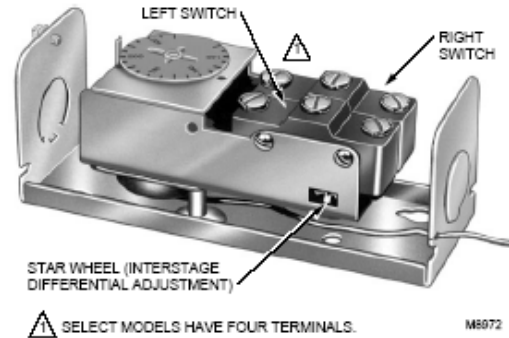

Fig. 32. Interstage differential adjustment on an L6008G.

L6008A Location Differential Calibration

The L6008A1093 is calibrated for applications where the bulb and controller case are located in the same control space.

If the bulb and controller case are located in separate rooms, and if the temperature in the two rooms is different, an adjustment is required. Adjust the dial setting (control space temperature setting) to compensate for the difference in temperature.

1. If the L6008A case is located in a room with a higher temperature than indicated on the dial setting, raise the dial setting the number of degrees listed in Table 3.
2. If the L6008A case is located in a room with a lower temperature than indicated on the dial setting, lower the dial setting the number of degrees listed in Table 3.

Table 3. Temperature Adjustments.

Difference Between Desired Room Temperature and Case Temperature		Reduce Dial Setting	
°F	°C	°F	°C
0	0	—	0
5	3	3/4	0.5
10	6	1-1/2	1
15	8	2	1
20	11	2-3/4	2
25	14	3-1/2	2
30	17	4-1/4	3
35	20	5	3
40	22	5-3/4	4
45	25	6-1/2	4
50	28	7	4
55	31	8	5
60	33	8-1/2	5
70	39	10	6
80	45	11-1/2	7

EXAMPLE:

In the example shown in Fig. 33, the L6008A case is located in a room with a lower temperature than the controlled space. Adjusting the controlled space setting (dial setting) is necessary to compensate for the temperature difference of 35°F (20°C) between the two rooms. Table 3 indicates that the dial setting should be lowered 5°F (3°C) to compensate for the 35°F (20°C) temperature difference.

Manual Reset

If the device includes manual reset (L4006E, L4008E), be sure to press the red reset button on the front of the case to make sure that the controller is not locked out on safety. When checking out the system, adjust the limit setting low enough so the temperature of the controlled medium reaches the high limit setting. When the limit setting is reached, the Aquastat Controller locks out and the burner shuts down. When the temperature of the controlled medium drops to the high limit setting, less the differential, push the manual reset button to make the system operative again. Reset the control to the proper high limit setting.

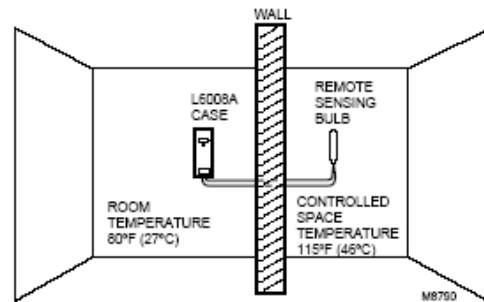

Fig. 33. L6008A calibration.

CHECKOUT**⚠ WARNING**

Explosion Hazard.
Can cause serious injury, death or property damage.
This product is intended for use only in systems with a pressure relief valve.

Check to make certain that the Aquastat Controller is properly installed and adjusted. Put the system into operation and observe the action of the control through several cycles to make certain it provides proper control of the system as described in the Operation section. Make any additional adjustments necessary for assuring comfort requirements.

R182J, R482J, R845A, R847A, R882J, RA89A, RA832A Switching Relays

These relays provide intermediate or heavy duty service in a wide variety of switching configurations.



- Relays with 24V control coils: R182J, R882J, R847A, RA89A, RA832A, and R845A.
- Relays with line voltage control coils: R482J.
- Relays with internal 24V transformer: R182J, RA89A, RA832A, R845A, and R847A.
- Relays for use with an external 24V supply: R882J.
- Heavy duty relays: R847J.
- R847A has flexible internal leads to provide either spst or spdt switching.
- RA832A has contacts for low voltage and millivoltage (Powerpile®) use.

CONTENTS

<i>Specifications</i>	2
<i>Ordering Information</i>	2
<i>Installation</i>	3
<i>Service and Checkout</i>	6

Specifications

IMPORTANT: *The specifications given in this publication do not include normal manufacturing tolerances. Therefore, this unit may not exactly match the listed specifications. Also, this product is tested and calibrated under closely controlled conditions, and some minor differences in performance can be expected if those conditions are changed.*

TRADELINE® MODELS

TRADELINE models are selected and packaged to provide ease of stocking, ease of handling, and maximum

replacement value. TRADELINE model specifications are the same as those of standard models except as noted below.

TRADELINE MODELS AVAILABLE:

- R182J—120 and 240V models.
- R482J—120 and 240V models.
- R845A—120V models.
- R847A—120 and 240V models.
- RA89A—24V controller.
- RA832A—120 and 240V models.

ADDITIONAL FEATURES: TRADELINE pack with cross reference label and special instructions.

STANDARD MODELS: See Table 1.

TABLE 1—SWITCHING RELAY SPECIFICATIONS.

Models	Application	Voltage (50/60 Hz)	Switch Action	Control Circuit	Coil Voltage (Vac at 50/60 Hz)	Relay Coil Current (A)	Contact Ratings (A)	
							AFL	ALR
R182J	For 24V thermostat control of line voltage devices.	120	Dpdt	3-wire	24	0.40 ^a	7.4	44.4
		240					3.7	22.2
R482J	Controlled by a line voltage controller	120	Dpdt	2-wire	120	0.08	7.4	44.4
		208/240					0.04	3.7
R845A	For hot water zone control systems or spst control of two separate loads.	120	Dpdt	3-wire	24	0.40	7.4	44.4
R847A	Provides switching for high-current loads such as cooling compressors.	120	Dpdt				22	100
		240						10
R882J	For use with separate low voltage power source.	24	Dpdt	3-wire	24	0.40	7.4	44.4
RA89A	For switching one line voltage load.	120	Spst				10.2	61.2
RA832A	For switching two line voltage loads having a common power source.	120	Dpdt	3-wire	24	0.40	7.4	44.4
		240					3.7	22.2

^a See footnote on page 3.

Ordering Information

When purchasing replacement and modernization products from your TRADELINE® wholesaler or distributor, refer to the Tradeline Catalog or price sheets for complete ordering number, or specify—

1. Order number.
2. Accessories, if desired.

If you have additional questions, need further information, or would like to comment on our products or services, please write or phone:

1. Your local Home and Building Control Sales Office (please check the white pages of your phone directory).
2. Home and Building Control Customer Logistics
 Honeywell, Inc., 1885 Douglas Drive North
 Minneapolis, Minnesota 55422-4386 (612) 951-1000

In Canada—Honeywell Limited/Honeywell Limitee, 740 Ellesmere Road, Scarborough, Ontario M1P2V9. International Sales and Service Offices in all principal cities of the world. Manufacturing in Australia, Canada, Finland, France, Germany, Japan, Mexico, Netherlands, Spain, Taiwan, United Kingdom, U.S.A.

^a **IMPORTANT:** The transformer on the R182 can over-heat when used with a series 20 thermostat if the total resistance of the thermostat (including thermostat wire and thermostat contact resistance) exceeds 2.5 ohms, add a 100 ohm, 10 watt resistor between the W and R terminals. Table 2 gives maximum thermostat wire runs; if longer runs are necessary, measure the resistance or add a 100 ohm, 10 watt resistor across terminals W and R.

See Table 2 for the ratings of built-in transformer (all transformers are rated at 120/240V, 50/60 Hz).

TABLE 2—TRANSFORMER RATINGS.

Transformer	Rating (watts)
R847A	7.0
RA89A	5.0
RA832A	—
R845A	—
R182J	6.5

FINISH: Gray enamel.

KNOCKOUTS:

Case bottom: (2) RA89A, RA832A, R845A; (3) R182J, R482J, R882J.

All models have 1 wiring hole in case top.

All knockouts are for 1/2 in. [12.7 mm] conduit.

APPROVALS:

Underwriters Laboratories Inc. Listed: RA89A; RA832A, R882J; R845A: File no. E4436, Guide no. XAPX.
 R482J: File no. E14480, Guide no. NLDS.
 R847A: File no. SA481, Guide no. SDFY.
 Canadian Standards Association Certified: R482J; R882J; R847A: File no. LR1620.

Fig. 1—Approximate mounting dimensions in in. [mm].

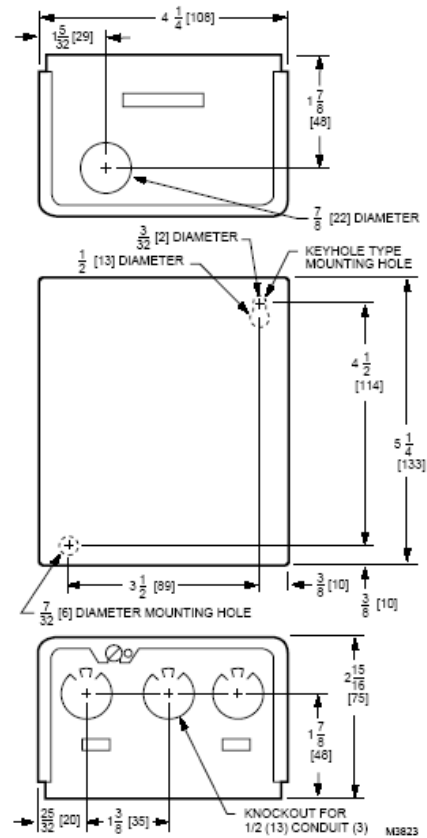

Installation

WHEN INSTALLING THIS PRODUCT ...

1. Read these instructions carefully. Failure to follow them could damage the product or cause a hazardous condition.
2. Check the ratings given in the instructions and on the product to make sure the product is suitable for your application.
3. Installer must be a trained, experienced service technician.
4. After completing installation, use these instructions to check out product operation.



WARNING

**ELECTROCUTION HAZARD.
 CAN CAUSE PROPERTY DAMAGE,
 SEVERE INJURY, OR DEATH.**
 Transformer core not bonded.

Disconnect power supply before wiring to prevent electrical shock or equipment damage.

MOUNTING

For replacement, mount the relay in the same location as the old control. If this is a new installation, locate the relay vertically on a solid wall or partition as near as possible to the device to be controlled. Select a location that is easily accessible for installation and service.

NOTE: To reduce possible transformer hum and relay noise that can be amplified by mounting surfaces of sheetmetal, plasterboard, and similar materials, place rubber or felt washers between the case and the mounting surface.

1. Position the relay and mark the mounting holes. See Fig. 1.
2. Start a screw for the keyhole type mounting hole in the upper right-hand corner. Turn down screw within about 1/8 in. [3.2 mm] of the surface.
3. Hang the relay on the screw, position the case, and start the bottom screw.
4. Tighten both screws.

IMPORTANT: The switching relay terminals are approved for use with copper wires only.

All wiring must comply with all applicable electrical codes, ordinances, and regulations. Follow any instructions furnished with the controlled equipment.

See Figs 2 through 10 for hookup diagrams for these relays. When two or more devices are to be controlled in parallel, the total current must not exceed the relay load rating. Fig. 11 is an internal view of the RA832A, showing terminal locations and barriers.

Never connect load terminals to a load that takes more current than the amount listed in the electrical ratings on the relay. See Table 3 for wiring length specifications.

Fig. 2—Internal schematic and typical hookup for RA89A.

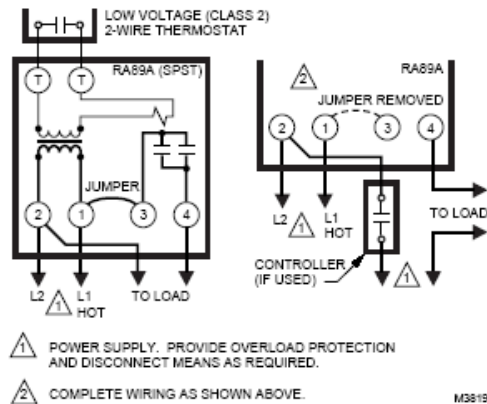

TABLE 3—WIRE LENGTH SPECIFICATIONS.

AWG Wire Size (Number)	Total Wire Length		Length of Run to Thermostat (2 wires)	
	Feet	Metres	Feet	Metres
22	120	38	60	18
20	200	61	100	30.5
18	300	91.5	1150	45.6
16	500	152.5	250	76
14	800	244	400	122

Fig. 3—Internal schematic and typical hookup for RA832A.

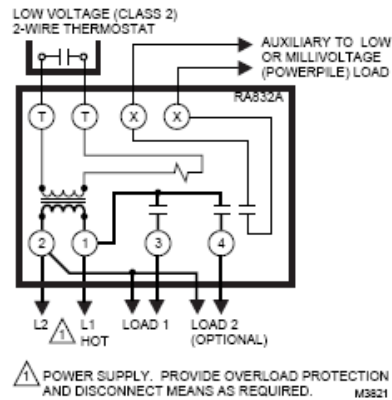

Fig. 4—Internal schematic and typical hookup for R182J.

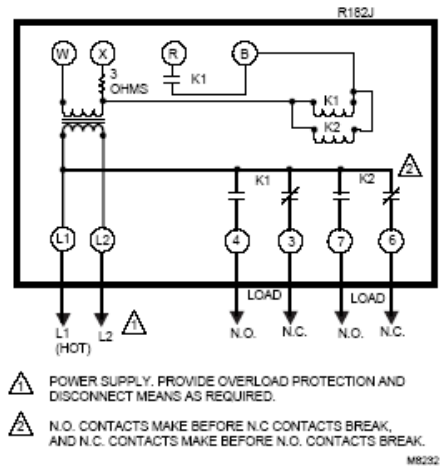

Fig. 5—Thermostat connections for R182J.

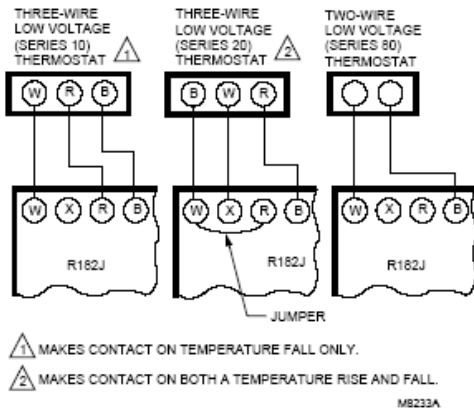

Fig. 6—Internal schematic and typical hookup for R482J.

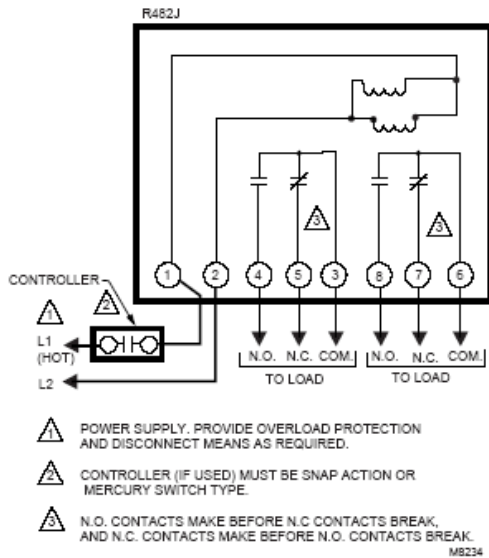

Fig. 7—Schematic diagram showing R845A in multizone, forced hydronic heating system. This arrangement is suitable for any number of additional zones.

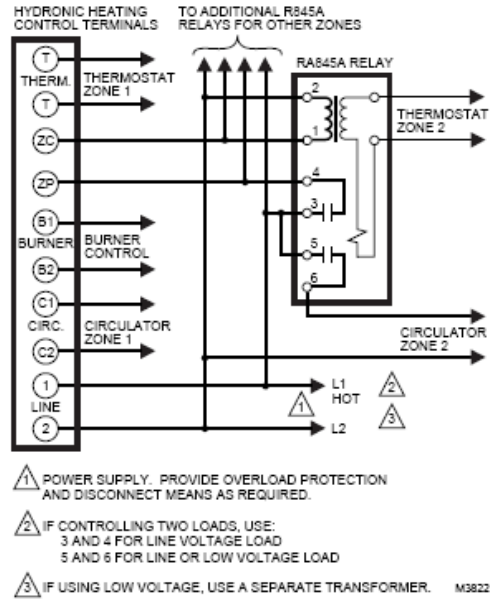
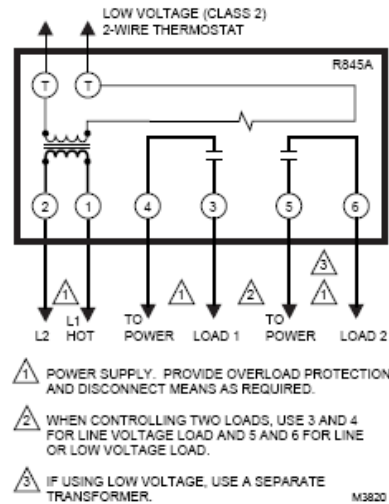

Fig. 8—R845A hookup for controlling two loads.



SUPERIOR BOILER TECHNOLOGIES

Section VII

GENERAL MAINTENANCE



CAUTION: Start with a review of the warnings, cautions, notes, and NBBI recommendations found in Section I of this manual.

Maintain a clean boiler room and provide quality water to the boiler and practice a planned program of pro-active periodic preventive maintenance.



WARNING: Never "dry fire" the boiler (operate the boiler burner without the boiler being filled with water). Do not operate the boiler without a functional Low Water Cut Off control. Do not operate the boiler without a functional 2nd High Limit (manual reset) switch.

Never reset a manual shut-off ("tripped") control. Remove the boiler from service immediately. The boiler must be inspected, and the root cause detected and repaired.



WARNING: NEVER operate the boiler without an ASME approved safety relief valve matched for both BTU/hr and pressure relief values. Test the relief valve at least annually and inspect at least every three years. Replace immediately as required or by code. See Safety Relief Valve manufacturer's tag.

NEVER operate a boiler if the safety relief valve has discharged. If the safety relief valve has discharged, something is wrong. Immediately remove the boiler from normal service and have a trained service technician investigate the problem.

NEVER add water to an overheated boiler, which can cause a conversion of the water to steam with an explosive increase in volume. Cut off the burner and allow the boiler to cool slowly.

NEVER fire a boiler without the spirals or turbulators in place in the fire tubes.

NEVER fire the boiler if the firebox or tubes have excessive buildup or are blocked.

NEVER bypass any of the controls on the boiler, fuel train, or burner. If a control is suspect, remove

the boiler from service and replace the defective control immediately.

NEVER fire a boiler above its rated input.

NEVER allow a boiler to be exposed to freezing conditions. If used outdoors, properly protect the system from the weather.

All TRIAD boilers are built to meet or exceed the Section IV ASME standard and are registered with the National Board to a maximum of 125 psi at 250°F. Operations of any boiler are not recommended above 220°F and should never exceed 240°F.

NEVER expose a boiler to thermal shock. Thermally induced stress cycling can result in metal fatigue failure. The minimum operational temperature differential between return and supply water is always recommended. NEVER introduce "cold" water into a hot boiler. Boiler return water should be no lower than 140°F before entering a hot boiler. NEVER exceed a maximum differential of 30°F.

In a closed system with good water quality and treatment, it is usually not necessary to drain the entire system. The introduction of new water into a hydronic system also introduces oxygen (possibly along with other dissolved gasses and minerals, particulates, and even organic material). This can cause internal corrosion, scaling, and fouling material to build up in the boiler and system. Begin a suitable boiler water treatment program to reduce oxygen, scale and sludge buildup, and to control pH and corrosion.

Frequently check that all ventilation and combustion air openings and louvers are clean and free of debris.

Do not expose coil model boilers to electrochemical corrosion. Flow rates in copper pipes and coils should **NEVER** exceed 6 fps to avoid erosion.

The coil should be periodically cleaned and back flushed. A water treatment program must be set up

in the evidence of scale build up or fouling. Do not use chemicals detrimental to copper.

OPERATORS & TRAINING:

Operators should be trained and knowledgeable, with a thorough familiarity of the system and its controls.

Operators should review and become familiar with all manuals, diagrams and warnings related to the system, the boiler and the burner.

Operators should be trained in the location and use of fire prevention equipment and procedures and should review and become familiar with all manuals, diagrams, and warnings related to the system, boiler, and burner.

Written site procedures should be developed and be readily accessible to all operators.

A permanent log book should be maintained in the boiler room to record maintenance work, inspections, tests, and other pertinent data.

Installation and startup should be done by a qualified service technician. Only a qualified technician should make burner or system adjustments in coordination with the responsible system design engineer.

The boiler should normally operate on its own controls once it receives the "Call For Heat" signal. If the burner should fail to light after a Call For Heat or the circulating pump fail to operate (after the minimum setting on the Dual Aquastat low temperature control has been reached), a system malfunction has probably occurred. The responsible system design engineer should be contacted and the cause of the problem investigated.

REMOVING A BOILER FROM NORMAL SERVICE:



WARNING: Make sure the burner is rendered inoperative before cutting off the water lines of a boiler. NEVER dry fire a boiler.

Turn off the control signal and the boiler. Ensure that the burner has shut down. Disconnect the power and the fuel supply to the boiler and all its accessories. Isolate the boiler by cutting off the water to the vessel and, if applicable, the coil.

Allow the boiler to cool slowly and then relieve any residual pressure (check the gauge and carefully open the safety relief valve) before performing maintenance.

Before returning a boiler to service ensure that the necessary corrective actions have been completed. Arrange to have the boiler inspected if required. Follow the initial startup procedures as discussed in Section V.

PREVENTIVE MAINTENANCE:

NOTE: Read the tag attached to the Safety Relief Valve -- FOLLOW THE MANUFACTURER'S INSTRUCTIONS COVERING INSPECTION, TESTING, AND REPLACEMENT.

At least annually (or as required by local code) ensure that the safety relief valve functions and that it cuts-off completely when released. During the boiler inspection and cleaning, remove the valve and check for deposits in the valve and plumbing. If the valve has buildup, fails to operate, or leaks, replace the valve only with an ASME approved relief valve of both the same pressure and BTU/hr rating. NEVER operate a boiler without a functional safety relief valve.

The boiler room area should be kept as clean as possible and free of all debris. The boiler room should be thoroughly washed down at least weekly to eliminate all dust and dirt. Weekly washing will help to extend the interval between boiler fireside cleanings. Follow a scheduled routine of pro-active preventive maintenance and be aware of the operation and condition of the system.

WATER

Properly treated vessel water is highly important, and critical for normal boiler service life and correct operation. This is water free of excessive minerals and gases with a nominal pH of 8.0 to 10.0. A pH level only a single digit away from these recommendations can make a dramatic difference. This is because each increasing level of pH is ten times greater than the prior level. So for example, a pH of 8 is ten times more acidic than a pH of 9, and one hundred times more acidic than a pH of 10. Conversely, a pH of 8 is ten times more basic (alkaline) than pH of 7.

Water Items	Levels
pH	8.0 to 10.0
TDS	<3000 ppm
Hardness CaCO ₃ (Calcium Carbonate)	<10 ppm
Alkalinity	<300 ppm
Organic Carbon	No sheen or Foam (1)
Iron	Colorless Liquid (2)
Suspended Solids	No visual turbidity (3)

- (1) Organic Carbon – After a water sample sits for 10 minutes there should be no visible solids.
- (2) Iron – Hold a water sample against a white background and there should be no visible yellow, red, or orange tinge.
- (3) Suspended solids – Vigorously shake a water sample for 30 seconds. There should be no visible sheen or foam.

Water samples should be taken from the lower part of the boiler, not from an area higher up such as the gauge glass.

Scale is a very effective insulator that will cause a loss of heat transfer efficiency and eventually tube sheet failure. Hard water results in a high amount of suspended solids. This condition is not covered under the boiler warranty.

Water that is too soft can be even more aggressive, so a minimum hardness is usually recommended.

Other items that also are harmful to the boilers include silica, iron, chlorides, and phosphates.

Following are several water treatment terminology items:

Alkalinity – Levels of this determine the ability of acids to be neutralized in water. Alkalinities can form carbon dioxide which is the primary culprit in corrosion. High levels can be from infrequent blowdowns or an overdose of alkaline water treatment chemical.

Chlorides – The higher the levels, the more corrosive the water. These can be controlled by increasing the amount of corrosion inhibitor or changing the type of inhibitor used.

Dissolved Oxygen – High levels in the boiler can cause pitting. It is very difficult to stop pitting once it has started, and can proceed very quickly.

Iron (Oxides) – Iron can start in the raw feedwater or from directly in the boiler due to corrosion. It can be a major culprit in developing of scale.

Oil - Oil can get into boiler water from various sources, including high levels in a new boiler, or from the condensate. It can contribute to scale formation.

pH – This is a measure of the level of acid or base of water. If too low (acidic) corrosion will increase, if too high then scale can develop. It can also cause water carryover. It is very important to continuously monitor pH levels.

Phosphates – High levels can cause scale formation. It usually comes from some type of pollution in the groundwater.

Sodium Sulfite – This is used to remove dissolved oxygen before it gets to the boiler. It reacts with oxygen to produce sodium sulfate (versus sulfite). Feedwater at all times should have slightly more than enough sodium sulfite to consume all the dissolved oxygen. If not fed continuously, the boiler may not be protected from oxygen corrosion. This is a very important aspect of water treatment.

TDS – Total Dissolved Solids are undissolved organic matter such as dirt and silt in the water. This can cause high hardness in feedwater.

A thorough review by a qualified water treatment system specialist should be done, and their recommendations followed.

DAILY (OR WEEKLY) PROCEDURES SHOULD VERIFY:

- Boiler operation on Call For Heat.
- Normal burner light-off.
- Pump operations.
- Fuel supply is not restricted.
- Return water temperature not below 140°F.
- Water treatment and expansion tank operations.
- Damper operations.
- Combustion air supply.

WEEKLY / MONTHLY PROCEDURES SHOULD INCLUDE:

- A thorough wash down of the boiler room.
- Checking the safety relief valve.
- Checking (and lubricating as required) all system motors and pumps.
- Checking and cleaning any strainers.
- Checking all venting and breeching.
- Review burner combustion readings.
- Air separation, water treatment, and expansion systems are operating per manufacturer's instructions.

DURING A LAY-UP PERIOD (or annually):

Shut down the boiler by following the procedure in "REMOVING A BOILER FROM SERVICE" below in this section.

Always allow the boiler to cool slowly. The water and firesides of the boiler should be inspected to determine their condition. Boilers out of service for extended periods (more than seasonal) should be properly laid-up dry -- consult the system design engineer. Ensure that idle boilers are protected from freezing conditions if laid-up wet.

A coating of 1/16" of soot (which is essentially unburned fuel and may present a fire hazard) can cause a 25 percent loss of efficiency. A coating of 1/8" of scale can cause a loss of 13 percent of BTU/hr transfer (and may lead to tube failure from thermal shock).

The frequency of cleaning will depend on the effectiveness of the water treatment program, the fuel type and efficiency of the burner settings, and individual characteristics of the site combustion air supply and breeching effectiveness. The time of year and the application will determine how often the boiler is being used.

Inspection should occur at least annually, or whenever a 1/8 inch of scale has built up in the vessel or coil. Initial 30- and 90-day inspections are recommended.

WATERSIDE CLEANING:

Shut off electrical and water supply to isolate the boiler from system and then drain and flush the vessel. Remove all inspection clean-out caps and supply/return lines. Inspect interior surfaces to check for signs of corrosion or pitting.

If advanced corrosion is evident, remove the boiler from service and arrange for boiler pressure testing or replacement.

A light coating of scale is acceptable, but deposits or evidence of sludge must be cleaned and water treatment procedures set up immediately. High pressure water spray should be directed at any deposits. Deposits are typically easier to remove while still warm and wet as long as the boiler has drained and cooled enough for maintenance.

Chemical agents may be used, but follow the manufacturer's instructions. On coil model boilers (LT, DHW, SH-C-LT, or SH-C-DHW) ensure that

the product is compatible with and safe for use on copper. TRIAD recommends using RYDLYME, a non-toxic, biodegradable solution available at local plumbing supply houses.

Inspect the safety relief valve.

If the boiler is not to be returned to service soon, dry the inside with forced warm air and limit exposure to humidity.

If the boiler is to be laid-up wet, then run through at least one full cycle after filling (before isolating from system) to drive off excess oxygen. This will help limit corrosion exposure.

FIRESIDE CLEANING:

Shut-off electrical and fuel supplies. Disconnect fuel supply and burner assembly. Remove firedoor adaptor, boiler jacket top, and boiler top plate. Inspect surfaces including turbulators/spirals, interior of fire tubes, and firebox for evidence of soot. Clean and remove all soot from the fireside of the boiler including the fire tubes, which can be done using a powerful vacuum cleaner and brush.

Excessive sooting indicates deficiencies in the fuel supply, burner settings, combustion air supply, and/or breeching. The system design engineer should be notified and a qualified technician should investigate the situation.

Inspect the spirals (in ATM models) or the turbulators (in HEP models). If any appear damaged then replace and have the burner inspected and readjusted.

Inspect firebox refractory for cracks or deterioration.

Repair with suitable refractory material if required, following the manufacturer's instructions. Inspect all sealing ribbons and rope and replace as required.

Re-install the burner, burner adapter, smoke hood, insulation disk and jacket top.

AFTER CLEANING

The burner should be cleaned, checked, and adjusted only by a competent service technician.

Record combustion product readings and compare with initial values. Significant changes should be

investigated. Have the technician leak test the fuel train and check components and verify operation of all operating and limit controls, interlocks, and gauges. Follow the burner manufacturer's startup instructions.

Lubricate all mechanical equipment such as fans and pumps and verify motor rotation.

Check all plumbing for leaks or missing insulation.

Thoroughly check all venting and breeching for blockage and leaks.

Arrange to have the water retested and the water treatment system serviced.

Have the boiler inspected by an authorized inspector as required. Local and state codes may apply.

Monitor the boiler through several complete cycles to confirm proper operation. Check burner for normal light-offs and complete shutdowns, and fuel feed for leaks. Return the boiler to service.

Update all maintenance information in the log book.

RESTARTING THE BOILER



WARNING: NEVER "dry fire" the boiler – operate the burner without the boiler completely filled with water.

Do not operate boiler without a functional Low Water Cut Off control.

Do not operate the boiler without a functional High Pressure Limit control.

Follow the initial startup procedures as outlined in Section V above and in particular refilling the boiler with water, properly re-connecting the fuel source and properly re-connecting the electric wiring.

Follow burner manufacturer's startup instructions.

Monitor the boiler through several complete cycles to confirm proper operation. Check burner for normal light-offs and complete shutdown

Record combustion product readings and compare with initial values. Investigate significant changes.

Return the boiler to service.

Update all maintenance information in the log book.

REMOVING A BOILER FROM SERVICE



WARNING: Verify that the burner has completed its cycle and that it has turned itself OFF.

1. Turn the power switch on the burner to OFF.
2. Turn the ON/OFF switch on the boiler to OFF.
3. Turn off the control signal to the boiler (thermostat).
4. Allow the boiler to cool slowly and then relieve any residual pressure (check the gauge and carefully open the safety relief valve) before performing maintenance.
5. Disconnect the fuel supply from the burner and the power to the boiler and all its accessories.
6. Isolate the boiler by cutting off the make-up water to the vessel.

If the boiler has been taken out of service due to an operational problem, ensure that the necessary repairs/services have been completed before putting it back into service. If required, arrange to have the boiler inspected. Follow the initial startup procedures as outlined in Section V above.

SUPERIOR BOILER TECHNOLOGIES

Section VIII

TROUBLESHOOTING



CAUTION: Start with a review of the OEM equipment information found in Section VI of this manual and the burner manufacturer's manual -- note all WARNINGS.



WARNING: BEFORE ATTEMPTING ANY ELECTRICAL CIRCUIT ANALYSIS REMOVE BOILER FROM NORMAL SERVICE AND REMOVE POWER FROM THE BOILER. Failure to use the required care and caution can result in electrical shock, injury, and extensive property damage.



WARNING: Make sure the burner is rendered inoperative before cutting off the water side of a boiler -- never dry fire a boiler.

NOTE: ASME's CSD-1 requires that only listed controls be used on boilers. Rebuilt controls do not comply with this standard and are never recommended.

These suggested guidelines are for general troubleshooting only by qualified individuals such as a licensed electrician or HVAC technician with both the appropriate technical training and the necessary experience to work on powered systems. See in Section I.



If you are not a professional repair person qualified to work on HVAC equipment stop here and call for service.

IF BOILER WON'T FIRE:

Complete the following steps in the order presented:

A. IF - NO "CALL FOR HEAT":

Check the circuit between the two low voltage terminals (T-T) in the Control Center and the actuating device which could be a thermostat; a control panel; a simple temperature control or an on/off switch.

If no problem is detected, then there may be a problem with the Control Center on the boiler. See item F, below for more about trouble shooting the specific controls.

Correct as necessary.

B. CHECK POWER TO BOILER:

Is the power switch on the boiler's electrical junction box in the ON position? If not, then switch it ON. Does this correct the problem?

If no, switch OFF the ON/OFF power switch and remove the screw on cover. Verify that service power to the boiler is present. Check the fuse(s)! Turn the power switch ON.

C. CHECK FUEL:

If there is a "Call For Heat" but no service power problems, then there could be a fuel adequacy problem. Ensure that there are no interruptions in the fuel source for the burner such as low natural gas pressure, inadequate gallons per hour of #2 oil, etc.

D. THERE IS A "CALL FOR HEAT", BUT THE BURNER WON'T FIRE :

Check that a Low Water Condition does not exist for the boiler. See LWCO in section III of this manual and the information in section VI about the specific Low Water Cut-Off (LWCO) on this boiler. If a Low Water Condition does exist for this boiler, then immediately take the boiler out of service until the cause of the problem is identified and corrected.

Check that the vessel temperature does not exceed the Maximum Safety High Temperature Limit of the L4006E. If the temperature exceeds this temperature setting, do not reset this control but immediately take the boiler out of service until the cause of the problem is identified and corrected.

Check that the vessel water temperature does not exceed the Operating High Temperature Limit of

the Control Center. If this is the condition, the boiler may be "Short Cycling" - see below.

If neither a low water condition nor a high temperature condition exist, then check the following burner items.

For power burners - check the following:

- Power switch is ON.
- Power light is ON.
- There is line voltage to terminals 1-2 in the control panel.
- The circuit to terminals 3-4 in the control panel is complete.

For atmospheric burners -

- Check for a 24 vac at the hot and common on the ignition module.

If no problems are detected, then there may be a burner problem. Consult the burner manual supplied by the burner manufactures. If there are problems at any one of the above points, possible a Control Center may be defective. Check item F of this section for information about the control.

E. BOILER "SHORT CYCLING:

Modular boilers are designed to provide a progressive response to the existing heat load. At some point in any cycle, the load will be matched or exceeded by the existing boiler response. It is normal for the burners, under such situations, to shut down temporarily and cycle on the limit controls similar to a household furnace.

Excessive cycling is usually indicative of a primary circulation system that is unable to carry away the BTU/hr output of the boilers. The causes can range from misadjusted controls to sensor location or primary pump performance.

Excessive cycling will inevitably occur if the boiler output has been oversized. Interconnection lengths between primary and secondary loops should be kept to a minimum so that loops can act as independent circuits.

Staging works best with boilers of approximately the same size. In the event that major differences exist in size, adjustments to cycle length times, and staging "null" (boiler stages that do not have boilers) positions can sometimes help. Contact the system design engineer.

F. TROUBLESHOOTING THE CONTROLS:

If you have reached this point in your troubleshooting, then one of the controls on the boiler has failed. Refer to the wiring diagrams in this manual or with each boiler and the OEM component information in Section VI for specifics on how to properly test each control.

LWCO - Whichever model is included on your boiler system, test for line voltage to terminals GN/2-P1. If there is power to the LWCO, then check power to the Control Center, which is connected in series from the LWCO. If the Control Center has no power, possibly the LWCO is bad.

Control Center - Hydrostat - Test for line voltage to terminals L1-L2. If there is no power to the control, check the source of both the neutral and power wires.

If there is power to the Control Center, then check the "Call For Heat" terminals -T-T for 24 vac. If T-T are without power, possibly this control is defective.

If terminals T-T are powered, then check the power at terminals B1-B2. It should be line voltage if the control is activated. If B1-B2 are without power, possibly this control is defective.

Note - power will not be present at C1-C2 unless the vessel water temperature has reached the minimum temperature set point at which the SH secondary circulator will start. If the vessel water temperature is above this minimum, then possibly this control is defective.

Replacing this control will require that the "blue" wire inside the control is removed from its internal terminal. Otherwise this control will cycle the boiler to maintain a "minimum" vessel water temperature.

Control Center - L8148E - Test for line voltage to terminals L1-L2. If there is no power to the control, check the source of the neutral and power wires. If there is power to the Control Center, then check the "Call For Heat" terminals -T-T for 24 vac. If T-T are without power, possibly this control is defective.

If terminals T-T are powered, then the check the power at terminals B1-B2. It should be low (24 vac) voltage if the control is activated. If B1-B2 are without power, possibly this control is **defective**.

Burner Control Relay - Power is provided by the Control Center from terminals B1-B2 to the burner control relay - terminals 2-7. The Hydrostat control provides line voltage to the burner relay.

The L8148E control provides low voltage (24vac) to the burner relay. Check the relay terminals 2-7 for power. Applying power to this relay will make the circuit between the relay 1-3 through the Safety High Limit (L4006E) and terminals 3-4 in the burner. If the circuit is made, then the problem lies within the burner. If the circuit isn't made, then possibly the relay or the High Limit is defective.

Safety Second High Limit - This aquastat will sense vessel water temperature and open its internal switch if the vessel water temperature meets or exceeds its set point. If the temperature does not exceed the set point and the switch is still closed, then this control is operating correctly.

Control Center - R845A - Test for line voltage to terminals 1-2. If there is no power to the control, check the source of the neutral and power wires.

If there is power to the Control Center, then check the "Call For Heat" terminals -T-T for 24 vac. If T-T are without power, this control may be defective. If terminals T-T are powered, then check the power at terminals 6-2 (which powers the coil circulator). If the control is activated then this should be line voltage. If 6-2 is without power then this control is may be defective.

BURNER AND PUMP WORKING BUT SYSTEM NOT HEATING, OR EXCESSIVELY SHORT CYCLING:

Contact the system design engineer and check the control settings, flow controls, valves, and system pumps and controls.

OVERHEATING:



WARNING: boilers heat water under pressure. When water is heated above its boiling point it can flash to steam if the pressure is removed -- maintain 18 psig minimum.

Should the manual 2nd high limit control, low water cutoff, or safety relief valve activate, the boiler should immediately be removed from service. It is very important that the cause of the situation be identified as soon as possible and corrective actions be taken immediately.

When a boiler has a severe pressure or over-heating condition causing large volumes of water, or any amount of steam, to blow out the pressure

relief valve, do not assume the operating and safety controls have control of the boiler.

The response to a severely over heating boiler should be to shut off the power and fuel supply and allow the boiler to cool slowly. Never introduce cold water into an overheated boiler. Adding water to an overheated boiler can produce explosive expansion as the water converts to steam.

The boiler should be thoroughly inspected for damage. Once the situation is corrected, the boiler should only be restarted by a qualified technician. Its operation must be fully monitored to confirm that the problem has been corrected before the boiler is returned to normal service.

BURNERS:

WARNING: Review the burner manufacturer's instruction manual for specific warnings and for technical and service information.



TRIAD boilers and burners are matched for efficient operations. Difficulty in setting the burner or in achieving smooth operation is usually indicative of a site problem - particularly if affecting more than one unit. Contact the system design engineer. Then, begin by checking the combustion air and breeching. Venting and breeching have very significant effects on boiler / burner operations.

A draft hood or barometric damper is recommended for each boiler.

BOILER RUMBLES

Venting and breeching have significant effects on boiler and burner operations. Check draft with a gauge. Draft should be between -.01" to -.05" WC when operating. A barometric damper might have to be installed to correct this.

Check that the fuel supply system is within the burner manufacturer's specification. Also check for proper combustion airflow, faulty breeching and loose venting. It may be worthwhile to extend the distances between the gas train components: regulators and controls. This lengthening allows a longer run that may help dampen supply pressure fluctuations. Condensation in the venting suggests a burner adjustment, combustion air, or breeching problem.

OVERHEATING



WARNING: boilers heat water under pressure. When water is heated above its boiling point it can flash to steam if the pressure is removed.

Should the manual high pressure limit control, low water cutoff, or safety relief valve activate, the boiler should immediately be removed from service. It is very important that the cause of the situation be identified as soon as possible and corrective actions be taken immediately.

Several malfunctions must usually occur before the safety relief valve is triggered. Should a boiler overheat, the response procedures should optimize the safety to people, and of the boiler and building. A readily accessible power disconnect and fuel cut off valve are recommended.

The response to a severely over heating boiler should be to shut off the power and fuel supply and allow the boiler to cool slowly. **NEVER** introduce cold water into an overheated boiler. Adding water to an overheated boiler can produce explosive expansion as the water converts to steam.

The boiler should be thoroughly inspected for damage. Once the situation is corrected it should be restarted by a qualified technician. Its operation must be fully monitored to confirm that the problem has been corrected before the boiler is returned to normal service.

BOILER LEAKS:



WARNING: Any failure of the pressure bound vessel requires strict adherence to the ASME code. Only a qualified, trained individual such as a licensed plumber or HVAC technician should attempt to service plumbing.

In the event that water is found around a boiler, a thorough investigation is warranted. There are typically two kinds of leaks possible: fitting leaks or failure of the pressure bound vessel.

Fitting leaks are typically evidenced by water accumulation around the outer perimeter of the vessel below the jacket. Because it can be difficult to determine which fitting is leaking, removal of the jacket may be required.

FITTING REPAIR:

After remove the boiler from service, do not simply

try to tighten the fitting. Instead, remove the fitting, thoroughly clean the threads, apply new sealant (pipe dope), and re-tighten the connection. This also is the typical procedure required for a control replacement or following boiler cleaning. Sweated joints that develop a leak will need to be drained and re-soldered.

PRESSURE BOUND VESSEL REPAIR:

This includes working on any portion of the tube sheets, re-tubing, any repair to the pressure containing portion of the shell, or internal coil leaks. Any such repairs must only be made according to the ASME Code and within the requirements of the NBBI as authorized and approved by a commissioned inspector. The inspector must pre-approve before repair work begins the method of repair proposed, workmanship, materials, and techniques to be used, and decide what inspection stages will be required. Boiler repair requires specialized knowledge, equipment, and procedures.

A leak involving the fire tubes is usually the result of thermal shock that may have been caused through the introduction of water at an excessive temperature differential, or as the result of the accumulation of scale or sludge from untreated water.

Such damage is not covered under the warranty.

It is possible to re-expand the tubes in place, but should only be attempted by a NBBI registered "R" (repair) stamp technician. The repaired shell must be pressure checked and reinspected before the boiler is returned to service. Welding of the tubes to the tube sheet is not acceptable.

However, unless the cause condition is eliminated, the situation will likely recur. Local and state code may also apply.

In the rare instance of a leak of the pressure bound shell such as a crack or failed weld, only an NBBI registered "R" (repair) stamp technician should attempt to repair the shell. The repaired shell must be pressure checked and reinspected before the boiler is returned to service. Local and state code may also apply.

If a TRIAD model with an internal coil has been exhibiting increased vessel pressure, then the coil may be leaking. If the "coil side" pressure is greater than the nominal vessel pressure (typical), remove the boiler from service, isolate the boiler "vessel water side" and bleed off the internal pressure.

Wait a few minutes. If the vessel pressure rises then it is likely that either the isolation valves are not fully shut or the coil is leaking. A professional should pressure check the coil.

As a practical matter, repairs to the internal coil are not feasible.

**The Following Is A Summary Of The Pre-Startup Sequence:
Read The Manual (See Section V)**

–	ACTION	REFERENCE
	Ensure local code compliance covering any necessary inspections and approvals	See Section I and contact system design engineer.
	Ensure there are no combustible materials or vapors in the area or air, and that power, water, and fuel supplies are off	See Sections I and V.
	Flush all system lines, and connect air separator, water treatment, and feed systems	See system manufacturer's manual, contact system design engineer.
	Connect secondary loop plumbing to factory (option) header	See BOILER MANUAL, contact system design engineer.
	Plumb safety relief valve output	See relief valve manufacturer's tag.
	Connect venting to expansion tank, vent and pressurize system	See BOILER MANUAL, contact system design engineer.
	Connect breaching between boiler and stack with barometric damper / draft hood	See BOILER MANUAL, contact system design engineer.
	Mount the burner (as required), Connect fuel supply to burner, Test fuel train for leaks	Review Section V -- Pre-startup, see burner manufacturer's manual.
	Connect 120 volt service and low voltage control lines (thermostat/panel) to the boiler	Contact system design engineer.
	Follow burner startup procedures	See burner manufacturer's manual.
	Monitor for several complete cycles, train operator, and bring boiler on line	Start maintenance log -- record initial readings and settings.
	Complete any required startup inspections	Sign-off startup.
	Balance system settings	See Sections III and IV.
	Prevent oxygen corrosion, pitting, scale formation, and mud accumulation	Pro-active preventative maintenance, see Section VII.
	Immediately remove from service if a manual reset has tripped, safety relief operated, or if a safety check is failed	Repair work must be done by a qualified service person, see Section VIII.
	Review the manual	Retain for reference.

TRIAD – Hydronic Systems Check Sheet (See Section IV and OEM Manuals)

Site/System:		Boiler Model:		Date: - to -	
Week 1:		Week 3:		Monthly:	
	Boiler operation.		Boiler operation.		Boiler operation.
	Normal burner light-off.		Normal burner light-off.		Normal burner light-off.
	System pumps & water supply.		System pumps & water supply.		System pressure & water supply.
	Check the fuel supply.		Check the fuel supply.		Check the fuel supply.
	Feed water and temperature.		Feed water and temperature.		Feed water and temperature.
	Water treatment & expansion tank.		Water treatment & expansion tank.		Water treatment & expansion tank.
	Damper operations.		Damper operations.		Damper operations.
	Combustion air supply.		Combustion air supply.		Combustion air supply.
	Visual check of P/T gauge.		Visual check of P/T gauge.		Visual check of P/T gauge.
	Check:		Check:		
	Check:		Check:		Wash down boiler room.
Week 2:		Week 4:			
	Boiler operation.		Boiler operation.		Check and lever test safety relief valve.
	Normal burner light-off.		Normal burner light-off.		Check (lubricate) all motors and pumps.
	System pumps and water supply.		System pumps and water supply.		Check and clean strainers.
	Check the fuel supply.		Check the fuel supply.		Check all venting and breeching.
	Feed water and temperature.		Feed water and temperature.		Check burner combustion readings.
	Water treatment & expansion tank.		Water treatment & expansion tank.		Check water treatment system.
	Damper operations.		Damper operations.		Back flush coil (as applicable).
	Combustion air supply.		Combustion air supply.		Check:
	Visual check of P/T gauge.		Visual check of P/T gauge.		Check:
	Check:		Check:		Check:
	Check:		Check:		Check: