

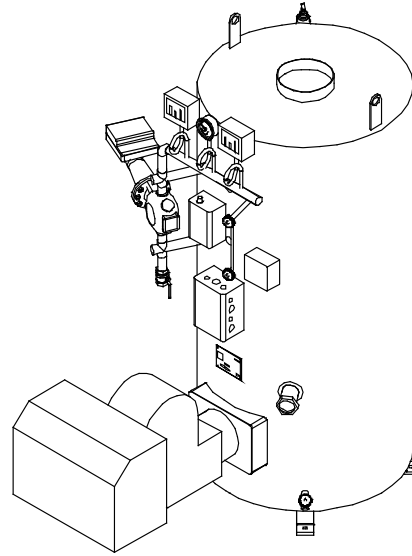

**OPERATIONS  
AND  
MAINTENANCE  
MANUAL**



**LOW AND HIGH PRESSURE STEAM BOILERS  
Series 300 through Series 2000**

**TRIAD Boiler Systems, Inc.**

**West Chicago, IL 60185**

Ph: 888-526-5245

Ph: 630-562-2700

Fax: 630-562-2800

Email – [sales@triadboiler.com](mailto:sales@triadboiler.com)

## **!!! ATTENTION !!!**

READ THIS MANUAL AND THE BURNER INSTRUCTION MANUAL VERY CAREFULLY! THEY ARE BOTH VERY IMPORTANT!

DO NOT SKIP OVER THE BOILER NOTES AND WARNINGS IN SECTION I. TRIAD IS A MANUFACTURER AND DOES NOT PROVIDE SITE SPECIFIC ENGINEERING. ALWAYS USE AN EXPERIENCED STEAM ENGINEER AND A STACK ENGINEER TO DESIGN YOUR SYSTEM.

THESE ITEMS ARE VERY IMPORTANT:

- WATER TREATMENT/QUALITY (See Section I & VII for more detail)
  - pH between 7 and 9
  - Total Dissolved Solids (TDS) levels around 2000 ppm (Levels above these can cause foaming / surging)
- VENTING
  - Draft no more negative than -0.05" wc
- NEAR BOILER PIPING
  - See Section V for recommended near boiler piping
- BLOWDOWN VALVES AND SAFE RELIEF VALVES
  - Check blowdown and relief valves weekly and/or monthly, especially the bowl of the McDonnell Miller 150. Make sure it is clear of sediment.
- FEEDWATER
  - Temperature of 160°F
  - Temperature below 200°F requires an oxygen scavenger
  - For multiple boilers; constantly pressurized feedwater loop with fast opening ASCO valves.
- BOILER SAFETY
  - Read the Warnings in this manual.
- MULTIPLE BOILER SEQUENCING
  - Use a panel for Parallel control of boilers (all boilers fire together.) Once pressure is reached, drop individual units off – maintaining system pressure with a minimal number of units.
  - It is recommended a Pressure Regulating Valve be used to isolate multiple boilers in a building that requires very low pressures such as 2 lbs or less.

- Be careful about old vacuum systems – consult an experienced steam engineer when retrofitting these.

**BOILER/BURNER STARTUP MUST BE PERFORMED BY AUTHORIZED TRIAD TECHNICIAN OR WARRANTY WILL BE VOIDED.**

# **TRIAD BOILER SYSTEMS, INC.**

## **Steam Boiler Operations and Maintenance Manual**

### **TABLE OF CONTENTS:**

Section I	<b>BASIC BOILER WARNINGS</b>
Section II	<b>STEAM BOILER MODEL INFORMATION</b> Packing Slip Wiring Diagrams
Section III	<b>STEAM BOILER SYSTEM COMPONENTS</b>
Section IV	<b>GENERAL OPERATIONS</b>
Section V	<b>INSTALLATION &amp; STARTUP INSTRUCTIONS</b>
Section VI	<b>OEM COMPONENT PRODUCT DATA</b>
Section VII	<b>GENERAL MAINTENANCE</b>
Section VIII	<b>TROUBLESHOOTING</b>

Retain this manual and keep it readily available, typically near the boiler.

# TRIAD BOILER SYSTEMS, INC.

## Section I

### BASIC BOILER WARNINGS



**STOP! READ THIS FIRST.**

**TRIAD STRONGLY RECOMMENDS THAT THE SYSTEM DESIGN ENGINEER THOROUGHLY REVIEW THIS MANUAL AND THE BURNER MANUFACTURER'S MANUAL BEFORE INSTALLATION AND STARTUP.**

**ALL OPERATORS SHOULD BE FAMILIAR WITH THIS MATERIAL - THIS MANUAL SHOULD BE READ, ITS MATERIAL UNDERSTOOD, AND ITS INSTRUCTIONS FOLLOWED. THIS MANUAL SHOULD BE READILY AVAILABLE IN THE BOILER ROOM AS A REFERENCE.**



The first and most critical step in the installation and startup procedure for any boiler system is to carefully read and understand the WARNINGS in this section.



The second step is to review this entire manual including the original equipment manufacturer's (OEM) component instruction information included in Section VI and the burner manufacturer's installation and instruction manual included with the boiler or burner.



The third and very important step is to ensure that the system and in particular the water, fuel, air supply, venting and breeching components have been properly installed and meet local codes before placing the boiler in operation.



The fourth and ongoing step is to ensure that the system is properly maintained.

**WARNING:** It is important to make sure the main power switch and all power to the boiler is **OFF** prior

to removing the cover of the main control box.

**NOTE:** Correct near boiler piping is critical to the proper operation of the boiler. Consult Factory Representative for recommended near boiler piping diagrams.

**NOTE:** Ensure proper venting by consulting a stack engineer. Proper boiler venting is critical for operation of your boiler. The flue must be as large or larger than the diameter of the collar opening. Actual sized depends on total distance of flue. It is important to keep the vent pressure at a negative and it is even more important that the pressure is no more negative than -0.05" wc. For example, a negative pressure such as -0.10" wc, could cause the burner flame to be pulled up into the firetubes, effectively over firing the boiler, which could lead to water surging and wet steam. A properly sized barometric damper will help mitigate this.

**NOTE:** Triad highly recommends that boiler feed water be treated before it enters the boiler. The water in the boiler should have a pH level of between 7.5 and 8.5, and in no case above 9.5. If feed water temperature is below 140°F it also requires an oxygen scavenger. **See WATER in Section III of this boiler manual.**

**NOTE:** If using a condensate return tank; (i) its capacity should be large enough to satisfy boiler consumption and maintain proper return tank temperature, (ii) it should be vented, (iii) the vent pipe should not be downsized, causing pressure to build up in the tank; (iv) return pipes should not be insulated to avoid overheating the return system that could cause a vapor lock in the pump.

**NOTE / WARNING:** Only properly trained personnel should install and maintain the water gauge glass. Wear safety glasses during installation. Improper installation or maintenance can cause immediate or delayed breakage resulting in injury and/or property damage. Never clean the gauge glass while pressurized or in operation.

**WARNING:** If using soap for leak testing, be careful as some soap are corrosive to certain metals. Clean all piping with water after the leak check has been

completed.

**WARNING:** Do not tamper with the low water safety cut off.

TRIAD Boilers can provide years of dependable service with proper maintenance and by carefully following the instructions and information provided in this manual and the burner manual. Failure to follow the directions and warnings can result in property damage or serious injury.

Independent Operation -- the boiler controls and accessories are activated by the "Call For Heat" circuit. As a result these components can be supplied with electricity and/or operate without warning. It is imperative that all power is removed and the control signal(s) is "locked out" before any maintenance is done on the boiler system.

**Breeching, Fuel and Burner Operations** -- The burner manual provided by the manufacturer contains a number of warnings concerning proper operation. Failure to follow these instructions, improper maintenance, improper or inadequate combustion air, fuel supply systems or breeching can result in exposure to Carbon Monoxide or other hazards that can result in property damage, possible explosion, serious injury, or death.

**Operating Limits** -- Boilers heat water under pressure. When water is heated above its boiling point it can flash to steam if the pressure is removed. In addition, "dry firing a boiler" (applying heat to a boiler with inadequate water inside) can result in an extremely destructive and hazardous condition caused by the rapid and potentially explosive buildup of extreme pressures and temperatures.

According to the National Board Bulletin it is a good idea to post signage near the boiler that states something similar to the following:

**EXPLOSION WARNING** - Do Not Introduce Water Into or Onto an Overheated Boiler

The boiler contains several limit controls to prevent excessive temperatures, but make sure these controls are properly set, maintained, and operated.

**CAUTION:** Boiler controls must NEVER be bypassed. If any manual reset control device has "tripped", the boiler control must NEVER be reset until the system has been thoroughly checked by a qualified technician. Failure to follow this warning can result in damage to the vessels and serious

personal injury.

The following is a list of *Recommendations for a Boiler Room* derived from the National Board of Boiler and Pressure Vessel Inspectors (NBBI -- Bulletin, Fall, 1997)

1) Keep the boiler room clean and clear of all unnecessary items. The boiler room should not be considered a storage area. The burner requires proper air circulation to prevent incomplete fuel combustion and the production of carbon monoxide.

2) Ensure that all personnel who operate or maintain the boiler room are properly trained on all equipment, controls, safety devices and up-to-date operating procedures.

3) Before startup, ensure that the boiler room is free of all potentially dangerous items like flammable materials that could cause a fire. Clear intakes and exhaust vents. Check for deterioration and possible leaks.

4) Conduct a thorough inspection by a properly qualified inspector such as one who holds a National Board commission.

5) After any extensive repair or new installation of equipment, make sure a qualified boiler inspector re-inspects the entire system.

6) Monitor all new equipment during startup to ensure its proper operation according to the manufacturer's specifications.

7) Establish a preventive maintenance schedule based upon the manufacturer's recommendations and a safety-testing program that follows CSD-1-1995, Part CM and the manufacturer's recommendations

8) Establish a checklist for proper startup and shutdown of boilers and all related equipment according to the manufacturer's recommendations.

9) Observe equipment extensively before allowing automatic operating systems to be used without supervision.

TRIAD reminds end-users that boilers and boiler rooms may fall under many code and regulatory requirements with local jurisdiction usually controlling. Installation should be carried out by competent personnel in accordance with the standards of the National Fire Protection Association, National or Canadian Electrical Code. State and jurisdictional codes beyond the scope of

the ASME Boiler and Pressure Vessel Codes should be followed in all cases. Jurisdictional authorities must be consulted prior to installation.

**TRIAD very strongly recommends that a competent and knowledgeable system design engineer be given design and implementation responsibility.**

## WATER

Properly treated vessel water is highly important, and critical for normal boiler service life and correct operation. This is water free of excessive minerals and gases with a nominal pH of  $7.8 \pm 0.5$ . A pH reading of around 10.0 or higher can result in priming and surging, which can cause wet steam and/or flooding of the steam supply and steam header. A pH level only a single digit away from these recommendations can make a dramatic difference. This is because each increasing level of pH is ten times greater than the prior level. So for example, a pH of 8 is ten times more acidic than a pH of 9, and one hundred times more acidic than a pH of 10. Conversely, a pH of 8 is ten times more basic (alkaline) than pH of 7.

Water Items	Levels
pH	7.5 to 9.5
TDS	<2000 ppm
Hardness CaCO <sub>3</sub> (Calcium Carbonate)	<10 ppm
Alkalinity	<300 ppm
Organic Carbon	No sheen or Foam (1)
Iron	Colorless Liquid (2)
Suspended Solids	No visual turbidity (3)

- (1) Organic Carbon – After a water sample sits for 10 minutes there should be no visible solids.
- (2) Iron – Hold a water sample against a white background and there should be no visible yellow, red, or orange tinge.
- (3) Suspended solids – Vigorously shake a water sample for 30 seconds. There should be no visible sheen or foam.

Water samples should be taken from the lower part of the boiler, not from an area higher up such as the gauge glass.

Raw makeup water (feedwater) contains dissolved oxygen, suspended solids such as dirt, minerals and organic materials that can cause corrosive failure and a buildup of scale inside the boiler. One way to lower the amount of dissolved oxygen in feedwater is use a sparge tube. This injects steam into the feedwater to increase the temperature to 160°F

to 180°F or so to remove oxygen.

Scale is a very effective insulator that will cause a loss of heat transfer efficiency and eventually tube sheet failure. Hard water results in a high amount of suspended solids. This condition is not covered under the boiler warranty.

Water that is too soft can be even more aggressive, so a minimum hardness is usually recommended. And both soft and hard water conditions can result in boiler surging, which can produce wet steam.

Too much oil present in the water will also cause foaming and surging. Other items that also are harmful to the boilers include silica, iron, chlorides, and phosphates.

**Following are several water treatment terminology items:**

Alkalinity – Levels of this determine the ability of acids to be neutralized in water. Alkalinities can form carbon dioxide in steam, which is the primary culprit in corrosion in condensate lines. High alkalinity also causes foaming and carryover in boilers. High levels can be from infrequent blowdowns, or an overdose of alkaline water treatment chemical.

Chlorides – The higher the levels, the more corrosive the water. These can be controlled by increasing the amount of corrosion inhibitor or changing the type of inhibitor used.

Dissolved Oxygen – High levels in the feedwater and boiler can cause pitting. It is very difficult to stop pitting once it has started, and can proceed very quickly. Preheating feedwater can help prevent this.

Iron (Oxides) – Iron can start in the raw feedwater, condensate return water, or from directly in the boiler due to corrosion. It can be a major culprit in developing of scale.

Oil – Oil can get into boiler water from various sources, including high levels in a new boiler, or from the condensate. It can contribute to scale formation and cause foaming.

pH – This is a measure of the level of acid or base of water. If too low (acidic) corrosion will increase, if too high then scale can develop. It can also cause water carryover. It is very important to continuously monitor pH levels.

Phosphates – High levels can cause scale formation. It usually comes from some type of pollution in the groundwater.

Sodium Sulfite – This is used to remove dissolved oxygen from the feedwater before it gets to the boiler. It reacts with oxygen to produce sodium sulfate (versus sulfite). Feedwater at all times should have slightly more than enough sodium sulfite to consume all the dissolved oxygen. If not fed continuously, the boiler may not be protected from oxygen corrosion. This is a very important aspect of water treatment.

TDS – Total Dissolved Solids is undissolved organic matter such as dirt and silt in the water. This can cause high hardness in feedwater, and result in foaming or carryover.

**A thorough review by a qualified water treatment system specialist should be done, and their recommendations followed.**



# TRIAD BOILER SYSTEMS, INC.

## Section II

### STEAM BOILER MODEL INFORMATION

This section includes a copy of the packing list for the boiler system that shows the model number and input firing rate that defines the size and capacity, and a wiring diagram for future reference.

If you should have a question or need service, it is important to provide the following information:

Boiler and Burner Model and Serial Numbers, Date of Installation and Job Number, which is shown on the packing list.

The boiler model and serial numbers can be found on the boiler registration tags on the front of the boiler.



**WARNING:** Please read the manual completely before attempting to place the boilers into service. It is extremely important that all of the information in this manual and the burner manufacturer's manual be studied before attempting to operate the boilers. Failure to follow the directions and warnings can result in property damage or serious injury.

Each TRIAD Boiler is certified to meet or exceed the requirements of the American Society of Mechanical Engineers (ASME) Code for pressure vessels. Each boiler is registered with the National Board of Boiler and Pressure Vessel Inspectors (National Board, NBBI). All Series 900 and 1600 Low Pressure steam boilers are UL Listed as a complete boiler/burner package. All boilers feature UL listed controls.

TRIAD Boiler Systems, Inc. is not responsible for general system design including venting and breeching. The boiler is only one component of the entire heating system.

Only trained and qualified individuals experienced in boiler room mechanics and local code requirements should be used to install the system.

#### APPLICATIONS

A typical application of a TRIAD low pressure steam boiler is for 1-10 psig and 240°F. Low pressure steam boilers are rated at 15 psig and high pressure boilers are rated at 150 psig MAWP.

Series 300 fires up to 399MBH  
Series 600 fires up to 700MBH  
Series 900 fires up to 1000MBH  
Series 1600 fires up to 1700MBH  
Series 2000 fires up to 2000MBH

Specifications are subject to change without notice.

## ABBREVIATIONS AND TERMS

*ASME* -- American Society of Mechanical Engineers -- boiler engineering code specifications.  
*BTU/hr* -- British Thermal Unit per hour, heat to raise 1 gallon of water 1°F.  
*Barometric damper* -- device for controlling stack draft; individual per boiler recommended.  
*Blow-Down* -- cleaning, opening a valve to release quantities of steam and water.  
*Boiler Control Center* -- activates burner control on "Call For Heat."  
*Breeching* - sheet metal ducts that carry exhaust from the boiler to the stack.  
*Burner relay* -- control circuit through Boiler Control Center to burner.  
*Call For Heat* -- completion of the thermostat control loop T-TY circuit.  
*Category I* -- non-condensing gas appliance that operates with a non-positive vent pressure.  
*Combustion Air* -- outside air required for correct burner operation.  
*Condensate* -- condensed steam, phase changed back to water giving up latent heat.  
*Cycle* -- from Call For Heat to burner shut-off after call is satisfied.  
*Dry Fire* -- heating a vessel with insufficient water, extremely hazardous.  
*Fire Tube* -- the connector between the firebox and vent, water surrounded, heat inside.  
*Flash* -- water heated above boiling will convert violently to steam on loss of pressure.  
*Fuel Train* -- connects gas or oil supply to burner, controls pressure, contains shut-off valves.  
*Gauge Glass* -- special glass tube displaying internal boiler water level.  
*HEP* -- Power draft burner; Note: Category I venting in a TRIAD boiler.  
*L.W.C.O.* -- Low Water Cut Off -- controls boiler by monitoring water level.  
*Latent Heat* -- heat associated with phase conversion from liquid to steam.  
*Lever Test* -- safety relief valve, raise manual lever to check operation, releases steam and water.  
*Low Pressure* -- 0 to 15 psig steam system.  
*MBH* -- 1000 btu per hour.  
*NBBI* -- National Board of Boiler and Pressure Vessel Inspectors, aka: The Board.  
*Near Boiler Piping* -- equalizer, header, feed, drain, and Hartford loop connections.  
*Nominal* -- under all conditions being within expected parameters.  
*OEM* -- Original Equipment Manufacturer, a purchased product component.  
*Operator* -- someone trained and competent to monitor in-use boiler systems.  
*Pigtail* -- special pipe connector (siphon loop, steam trap) to gauges and controls.  
*Pressure Bound Vessel* -- NBBI registered ASME code built boiler shell.  
*Pressure Controller* -- limits boiler operating pressure, part of burner control circuit.  
*PSIG* -- pounds per square inch gauge (vs absolute), typically used as just psi.  
*Raw Water* -- untreated for ph, solids, dissolved minerals and gasses, and organics.  
*Remove From Service* -- properly disconnect and render inoperative.  
*Safety Relief Valve* -- ASME rated steam relief valve matched for pressure and heat capacity (15 psig max.).  
*Scale* - the solidification of dissolved minerals from water, typically carbonates.  
*Short Cycle* -- frequent turning on and off of burner, which is inefficient.  
*Sight glass* -- glass port for viewing firebox.  
*Skim Tap* -- a flange at the water line for the cleaning process required for new (and dirty) boilers.  
*Solenoid* -- electrically controlled valve used to allow makeup water to return to vessel.  
*Staging* -- the controlled firing in sequence of modular boilers to meet varying demands.  
*System Design Engineer* -- responsible for system compliance and specifications.  
*Technical Service* -- knowledgeable, licensed, trained, experienced, and qualified.  
*Thermal Shock* -- cyclic metal fatigue caused by excessive heat differentials.  
*Tripped* -- a device that has been activated and must be physically re-set.  
*Tube Sheet* -- part of the pressure vessel that retains the tube ends.  
*Turbulator* -- in-firetube device provides cleaning and heat transfer from the firetubes.  
*UL* -- Underwriters Laboratories.  
*Venting* -- to release to atmospheric pressure, commonly also used to mean breeching.  
*Water Hammer* -- water driven at high speeds by steam and trapped air.  
*Water Treatment* -- controls ph, hardness, dissolved minerals and gasses, and organics.

## TRIAD MODULAR STEAM BOILERS

Series 300 fires at 300 – 399MBH  
 Series 600 fires at 600 – 700MBH  
 Series 900 fires at 800 – 1000MBH  
 Series 1600 fires at 1100 – 1700MBH  
 Series 200 fires up to 2000MBH

### STANDARD COMPONENTS:

<b>Series Number</b>	<b>300</b>	<b>600</b>	<b>900</b>	<b>1600</b>
X4-400 Powerflame Gas Burner	X			
X4-700 Powerflame Gas Burner		X		
JR30A Powerflame Gas Burner			X	
JR50A Powerflame Gas Burner				X
<b>Other Components</b>				
L404F1060 Pressuretrol – operating (LP)	X	X	X	X
L4079B1033 Pressuretrol – safety (LP)	X	X	X	X
Operating Light	X	X	X	X
*P7810C – Solid State/multi function pressure/mod control with operating light				
Pressure Gauge	X	X	X	X
Pressure Relief Valve	X	X	X	X
150 Water Level Control	X	X	X	X
750-MT-120 Low Water Cut-Off – Manual reset	X	X	X	X
Gauge Glass Assembly	X	X	X	X
R845A Control Center	X	X	X	X
1 1/4" Ball Valve and fittings for blow down		X	X	X

\*All low pressure steam boilers come standard with the L404F1060 & L4079B1033 controls. The P7810C is standard on high pressure steam boilers and when low pressure steam boilers have modulation added to them.

### OPTIONAL COMPONENTS:

#### Barometric Dampers:

MG1-8"

For Gas or Gas/Oil, Field Mounted.

RC-6"

For Oil-fired 300 model Boiler only, Field Mounted.

#### Burners:

##### Series 300:

Oil Fired – (Riello)

Natural Gas or #2 Oil (Requires Gas Pilot For Firing).

##### Series 900 or 1600:

Spark Ignition System

GPDS Spark Ignition

Oil-Fired: CR1-O

For No. 2 Oil.

Low Nox - NPM 30 or NPM 50

Low Nox natural gas burner

Combustion Intake flange

For Sealed Combustion/Side-Wall Venting.

CSD-1

For Power Flame Dual Fuel Burners, standard on all others.

IRI Gas Train

Motorized Gas Valves, Alarm Bell.

Modulating Gas Train

Motorized Gas Valves.

#### Cleanout Openings:

CLNOUT 22

2 Nipples and Caps – installed top-front only

CLNOUT 44

4 Nipples and Caps.

Fan/Damper Relay – FDR

# TRIAD BOILER SYSTEMS, INC.

## Section III

### STEAM BOILER SYSTEM COMPONENTS

TRIAD boilers are designed to very strict standards; certified to meet and exceed American Society of Mechanical Engineers (ASME) codes; and registered with the National Board of Boilers and Pressure Vessel Inspectors (NBBI).

TRIAD uses only UL listed controls and UL listed burners and gas trains. Every boiler is a Category I non-condensing gas appliance.

#### TYPICAL BURNERS

<b>Series 300:</b>	<b>Power Burners</b>
Gas	Power Flame X4-400 or Riello G400
Straight Oil	Riello F10
<b>Series 600:</b>	
Gas	Power Flame X4-700 or Riello G750
<b>Series 900:</b>	
Gas	Power Flame JR30 or Riello RS 28
Oil or Dual	Power Flame CR1 or Riello RLS28
Low Nox	Power Flame NPM 30
<b>Series 1600 &amp; 2000:</b>	
Gas	Power Flame JR50
Oil or Dual	Power Flame CR2 or Riello RLS 38
Low Nox	Power Flame NPM 50

#### ELECTRICAL

Standard - 120 volts, 60 Hz, single phase  
Series 300 -- 20 amps per boiler  
Series 600, 900 and 1600 -- 30 amps per boiler



**CAUTION** Some local codes require a master power off switch for boiler room equipment and may specify its location. Electrical service and connections must meet all applicable codes.

#### INDIVIDUAL BOILER CONTROLS

Individual component product information is included in Section VI. The configuration for your specific boilers is shown in Section II. Burner manuals are sent with the burner.

### SYSTEM COMPONENTS

#### ELECTRICAL WIRING BOX

The electrical box with a screw-on cover contains various electrical wiring components for each boiler - ON/OFF switch; fuses, terminals and relays for fan damper control, lockout control, etc.

The boiler limit control circuit starts & ends in this box.

Field wiring connections for line voltage service power and low voltage (TT) thermostat/control are provided in this box via clearly marked, screw-in terminals.

#### R845A - CONTROL CENTER

Used on Steam boilers in conjunction with Low Water Cut-offs (LWCO) and pressure controls to manage the overall operation of the boiler, cycle the burner and illuminates the "Call For Heat" light.

The R845A control is activated by closing the circuit between the two low voltage terminals (T-T) via a 24 vac 2-wire thermostat or a control panel otherwise known as a "Call For Heat".

The R845A control is wired in series with the Low Water Cut-off controls (LWCO) and the Pressure controls and will activate the boiler control circuit only if a low water condition does not exist and the high pressure limit has not been exceeded.

#### L404F1060 – Operating Pressure On/Off Control

This line voltage, pressure-sensing switch has an adjustable differential and automatic reset. When boiler steam pressure rises past the control set point, the switch opens, stopping the burner operation. When the boiler pressure falls to the set point minus differential, the switch closes to restart the burner.

#### L4079B1033 – Safety Pressure High Limit Control with Manual Reset.

This is a line voltage, steam pressure sensing switch

### SECTION III

with a manual reset trip function. When the boiler's steam pressure rises above the set point of the control, its switch opens and the manual reset trips to shut down burner operation.

If the manual reset is tripped OPEN then a serious problem exists with your boiler. The boiler should not be put back into service until the problem has been identified and corrected

### **P7810C – Operating Pressure On/Off Control and Safety Pressure High Limit Control with Manual Reset.**

The P7810C is a line voltage control that performs the same functions as the L404F1060 and L4079B1033 but in one control. The P7810C also has a 4-20mA modulating signal.

For On/Off Control, it uses a separate integral electronic pressure sensor with an adjustable set point, an adjustable differential and automatic reset. When boiler steam pressure rises past the control set point, the switch opens, stopping the burner operation. When the boiler pressure falls to the set point minus differential, the switch closes to restart the burner.

For High Limit Control, it uses a different and separate integral electronic pressure sensor with an adjustable set point and has a manual reset trip function. When the steam pressure rises past the control set point, the switch opens and the manual reset trips, which shuts down the operation of the burner. When the boiler pressure falls below the set point, the burner will not restart operation until this control has been reset manually.

If the manual reset is tripped OPEN then a serious problem exists with your boiler. The boiler should not be put back into service until the problem has been identified and corrected

If less than 2 psi operating pressure is required the P7810C is not the best choice, instead you should revert to the standard L404F and L4079 operating controls.

### **150 SMD - LOW WATER CUT OFF (LWCO)**

This two-stage control senses the water level within the vessel shell to switch the power for both the feedwater solenoid and the burner. When the water level has dropped approximately  $\frac{3}{4}$  of an inch below the nominal operating water level (about 2 to 3 gallons), the first stage switch closes providing line voltage to the boiler feedwater solenoid. This circuit

will remain powered until the water level returns to normal. If the water level continues to fall, the second stage switch opens which stops the burner operation. The burner switch will be closed once the necessary feedwater has been provided to the boiler.

NEVER "dry fire" (operate a boiler with insufficient water). It is an extremely destructive and a dangerous practice.

### **750-MT-120 – SAFETY LOW WATER CUT OFF WITH MANUAL RESET**

This control senses the water level within the vessel shell to shut down the burner in a low water condition. If the vessel water level drops below the minimum, the control switch opens, tripping the manual reset and stopping the operation of the burner. This control requires a manual reset.

If the manual reset is tripped OPEN then a serious problem exists with your boiler. The boiler should not be put back into service until the problem has been identified and corrected.

NEVER "dry fire" (operate a boiler with insufficient water) It is an extremely destructive and dangerous practice.

### **67M – SAFETY LOW WATER CUT OFF (LWCO) with MANUAL RESET – LOW PRESSURE STEAM**

This control is used on older Low Pressure Steam boilers (15 lbs) built prior to 2011 and senses the water level within the vessel shell to shut down the burner in a low water condition. If the vessel water level drops below the minimum, the control switch opens, tripping the manual reset and stopping the operation of the burner. This control requires a manual reset.

If the manual reset is tripped OPEN then a serious problem exists with your boiler. The boiler should not be put back into service until the problem has been identified and corrected

NEVER "dry fire" (operate a boiler with insufficient water) It is an extremely destructive and dangerous practice.

### **ON/OFF SWITCH & FUSES**

The ON/OFF switch and dual fuses provide a safe way of removing power from the boiler.

NOTE: Replace fuses only with the same type as

specified inside the wiring box cover and then only after determining why the fuse(s) blew.

### **RELIEF VALVE**

The relief valve should NEVER function under normal operations. If it has then something needs to be adjusted. Many codes require periodic testing and replacement of relief valves -- the user must meet local code requirements. Many codes require that the safety relief valve be freely vented to the outside atmosphere (potential line freezing must be considered). Relief valves are sized for both their pressure rating and their BTU/hr load. Replace only with properly sized, ASME approved units designed for steam systems -- SEE MANUFACTURER'S TAG ATTACHED TO THE VALVE.

### **PRESSURE GAUGE**

Indicates boiler vessel operating pressure.

### **LIFTING LUGS** (optional on 300 series)

Lifting point of boiler for ease of installation.

### **FAN DAMPER RELAY** (optional)

SQUARE D 8501 DPDT – with line voltage coil

### **BAROMETRIC DAMPER** (optional) **FIELD MG1-8, RC-6**

TRIAD recommends one barometric damper be installed for each boiler or at least one be installed in the breeching between the first boiler and the stack.

### **OPERATING LIGHT**

“Call For Heat” indicator mounted on Boiler Control Center. This is integral to the P7810C control.

### **CLEAN-OUT OPENINGS** (Optional)

Nipples and caps are for easier inspection and boiler vessel service.

### **OTHER SYSTEM COMPONENTS**

In addition to the boiler and burner, a complete heating system may include the following:

Near Boiler Piping – field installed piping that connects the boiler to the main steam header. Typically incorporates a Hartford loop. The separation between the equalizer and the condensate return loop should always be kept to a

minimum; use a close nipple whenever possible.

Steam Header – Connects to near boiler piping. The header then transfers steam to heating zones. Header MUST always be a minimum of 24” above the top of the boiler – this helps to ensure dry steam production.

Air Separation System -- Removes dissolved gases from recirculating system water, which TRIAD highly recommends for open systems.

Water Treatment System -- Helps ensure water quality and control of ph, hardness and dissolved materials.

Vent and Expansion System – Typically part of the boiler feed water and condensate return system.

Water Pressure Reducing Valve -- Drops supply water to system pressure and maintains a minimum (18 psig) pressure within the system.

Gas Line Pressure Valve -- Lowers supply gas pressure to gas train range (typically less than 14” WC -- 0.5 psi).

Oil Supply System -- Allows single or two line transfer of fuel oil from the supply tank to the burner train.

Thermostat Control -- Varies between a simple two wire thermostat to a microprocessor outdoor reset control panel. Some applications may use a remote application sensor that closes the boiler thermostat “Call For Heat” control circuit.

# TRIAD BOILER SYSTEMS, INC.

## Section IV

### GENERAL OPERATIONS

Prior to starting your boiler system, please familiarize yourself with each boiler control by reviewing both Sections III and VI or this manual

TRIAD steam boilers may be used in many different applications. The boiler is designed to convert water to steam under controlled pressure. The amount of steam produced is in direct proportion to the BTU/hr (British Thermal Units per hour) rating of the burner. The steam temperature and the pressure – pounds per square inch gauge (typically referred to as psi) are always directly related.

For example, in a typical space heating application, a boiler fired at 900MBH/hr will produce up to 749 pounds of steam per hour. The same boiler firing at 600MBH/hr would produce approximately 512 pounds of steam per hour. The difference between the two examples is the firing rate of the burner and thus the heat produced. In either case, the steam pressure and temperature would be the same - the volume of steam produced would be different.

Since virtually all of the thermal output is carried as “latent heat” (heat required to convert water to steam) the heat transfer is not controlled by the steam pressure.

It is imperative that the initial setting for each control (i.e. Operating Pressure Limit, Safety Pressure High Limit, etc.) be made before attempting to start up any boiler

All TRIAD Steam boilers are equipped with a Control Center; two low water cutoff (LWCO) controls - one with a manual reset and dual pressure limit controls - one with a manual reset. Other controls may be installed as add-on options

Unless otherwise noted, all control circuits and wiring connections are line voltage.

The R845A Control Center requires a “Call For Heat” to activate it. This is accomplished by closing the circuit between the two low voltage terminals (T-T) via a 24 vac 2-wire thermostat; an outdoor reset control panel; or a simple temperature control.



Power is supplied to the boiler by setting the ON/OFF switch to the ON position. With this switch in the ON position, all of the controls on the boiler are “live” and great caution must be taken before touching any wiring. Turning the ON/OFF switch to OFF means only that the power to the boiler mounted controls is off.

**NOTE:** Power to controls and systems not mounted on the boiler (fan dampers, induced draft fans, etc.) is not provided by the boiler controls even though these “off boiler” systems may be activated by boiler mounted relays, etc. Extreme caution must be taken before attempting to service any “off-boiler” systems as there may still be electricity present in them even with the boiler ON/OFF switch in the OFF position.

NORMAL Operating Conditions are when the vessel steam pressure is not above the operating high limit - see L404F1060 or P7810C Pressure Control **and** a low water condition do not exist - see LWCO controls.

ABNORMAL Operating Conditions would include but not be limited to: electrical failure; fuel interruptions; vessel steam pressure that exceeds the control set points, a low water condition; a malfunctioning control; etc.

Specific wiring diagrams for your boiler system are included in Section II of this manual.

Descriptions of controls and their operations are generic. See Section VI of this manual for the manufacturer’s instructions. Specifications and configurations are subject to change without notice.

### ALL STEAM MODELS

These single function boilers provide low pressure steam – max 15 psi or high pressure steam – max 150 psi.

### SETTINGS

Nominal system design pressure is established by the pipe size chosen by the design engineer. Once the initial setting is established, adjustment may be

required based on system performance and design criteria.

#### Operating Pressure Limit Control (L404F1060)

Typical operating pressure for a low pressure heating application is 3 to 5 psi - plus/minus 1 to 2 psi. Other applications may be quite a bit higher.

#### Safety Pressure High Limit Control - Manual Reset L4079B1033 or P7810C.

Nominal operating pressure that is set as the Operating Pressure Limit (above) plus 2 to 3 psi.

### **OPERATION**

Under Normal Operating Conditions a “Call For Heat” to the R845A Control Center would activate the burner control circuit that starts the burner ignition cycle (see burner manufacturer’s instruction manual) and illuminates the operating light on top of the control or in the P7810C. The heat applied to the vessel water increases the vessel water temperature to boiling converting the water to steam. As the water is “steamed-off”, “makeup water” must then be supplied by the boiler feedwater make-up system.

Boiler Feed Water Control (150BMD) -: A float in this control senses when the actual water level in the boiler reaches 3/4” below the normal water level of the vessel and closes a contact to provide power to the field installed, normally closed, feedwater solenoid. When powered, this solenoid opens to provide “make-up” water to the boiler until the float senses that the water level in the boiler has reached its nominal level again at which time power is cutoff to the solenoid which then closes, stopping the flow of “make-up” water.

This cycle will repeat as the boiler water level rises and falls during the normal operation of making steam.

Multiple Boiler Setup – It is highly recommended to use a panel to control multiple boilers. They should be operated in a Parallel Manner (meaning all boilers should fire at same time.) Bring the boilers up gradually, starting on low fire, and once the desired system pressure is reached, then drop the individual units off – maintaining system pressure with a minimal number of units. Do not try to reach system pressure by firing one boiler up to high fire, then firing another up to high fire, etc.

When dealing with steam, it is much better to bring the entire system on gradually, then drop off units as they are not needed.

**NOTE 1** - At times the boiler pressure may rise above the setting of the Operating Pressure On/Off Control - L404F1060 or P7810C, which will open the contacts in the control stopping the burner from firing.

Once the vessel pressure drops below the differential set point in this control, the contacts in the control will close and the burner ignition will start again. Typically this condition may occur when the system is approaching dynamic balance near the nominal system operating temperature -- the entire output for the boiler exceeds the current system needs. It may also occur if - the boiler sequencing is too aggressive or the boiler has been oversized for the system.

**NOTE 2** - If the manual reset circuit of the Safety Pressure High Limit Control - L4079B1033 or P7810C - is tripped - this indicates a serious problem with your boiler. It is mandatory that the boiler be immediately removed from service and the cause identified and corrected. It is possible that the other high limit pressure control was set wrong or has malfunctioned (very serious condition). One or both controls may need to be replaced. The system may have to be inspected before the boiler is returned to operation. .

**NOTE 3** - Low Water Cut-Offs (LWCO) limits are not adjustable - their control limits are fixed. If the manual reset circuit of the LWCO - (67M) has “tripped”, this indicates a serious problem with your boiler. It is mandatory that the boiler is removed from service and the problem be identified and corrected. It is likely that the other LWCO (150BMD) has malfunctioned (very serious). One or both controls may need to be replaced.

The boiler will continue to operate until the “Call For Heat” is satisfied and the control is deactivated by opening the circuit (T-T) OR an ABNORMAL Operating Condition has developed.



# TRIAD BOILER SYSTEMS, INC.

## Section V

### INSTALLATION & STARTUP INSTRUCTIONS



**STOP:** Before proceeding with this section, carefully read the other Sections in this manual.

#### A. UNPACKING

Always protect boilers from the weather.

All cartons and crates should immediately be inspected for any damage. If any damage is found at the time of delivery, proper notation should be made on the carrier's Bill of Lading before signing for delivery. Damage claims should be filed immediately with the carrier. Claims of shortages should be filed in writing with TRIAD Boiler Systems, Inc. within five (5) days of receipt.

For those boilers with leveling legs, the boiler is shipped with leveling bolts to be field installed into the leveling legs. .

The burner carton contains the manufacturer's instruction manual and gas train components.

The wiring diagram(s) for the boiler are included in this manual and copies are included in the electrical wiring box. Suggested "near boiler piping" diagrams are available in TRIAD's Boiler Manual.

The boiler tags should be checked to confirm the boiler model, the serial number the burner model and burner rating. These should agree with the information shown on the Packing Slip found in Section II of this manual.

#### B. WHERE TO LOCATE

Boilers must be protected from weather and should not be exposed to potentially freezing temperatures.

Boilers should be located as near as possible to the stack of the breeching system. Consideration should be given to water drainage for the relief valve and LWCO's and access for boiler service.

Install the boiler only on a level, non-combustible surface and level it with the leveling bolts provided. Sufficient clearance is required for operation and

service. Suggested minimum clearances for service access are: 48" in the front; 18" for the sides and rear; and 24" up to the breeching and header connections. However, clearances on sides and rear for boilers above 50 PSIG are 36".

The near boiler piping and the rise to the header are particularly important for proper boiler operation. Do not reduce the size of the steam supply opening. Ensure that the near boiler piping is as specified by Triad and/or the design engineer.

The rise in the connector from the boiler to the breeching system can be its most effective part. Generally, the longer the rise, the better the draft. A draft hood or barometric damper for each boiler is generally recommended. At a minimum, one damper should be located in the breeching between the first boiler and the stack. Additional information is available in the TRIAD Boiler Manual. Also, the installation must comply with local codes.

Adequate combustion air must be provided to the boiler room.

Provisions must be made for adequate water supply and treatment - the condensate return/makeup water/boiler feed system. ***When using multiple boilers, Triad highly recommends having a permanently pressurized feedwater loop with fast opening ASCO valves so that water is feed into boilers in a timely manner.***

Fuel supply and electrical service must be provided. Typically, burner startup service will be required.

#### C. INSTALLATION – WARNINGS/CAUTIONS



**CAUTION:** Before connecting the fuel supply and burner, be sure to read the burner manufacturer's manual.



**WARNING: BEFORE ATTEMPTING ANY ELECTRICAL SERVICE, DISCONNECT POWER FROM THE BOILER.**

1. ***TRIAD does not design boiler rooms.*** TRIAD

recommends that a competent system design engineer be retained to design the heating system, supervise the installation and oversee the startup

2. Only a qualified individual such as a licensed electrician should attempt to service electrical or control circuits. Only a qualified HVAC technician should attempt to service or to start up a burner. .

3. The installation must conform to the local codes having jurisdiction over your area and this type of equipment. Without local codes, refer to the National Fuel Gas Code. At a minimum BOCA code compliance must be met.

Where required the American Society of Mechanical Engineers (ASME) Safety Code for Controls and Safety Devices for Automatically fired Boilers (CSD-1) must be met. User insurance requirements may be a factor in the installation requirements.

Connections to water, breeching and electrical service must meet all applicable codes. These may include but are not necessarily limited to the National Electrical Code, BOCA standards on Combustion Air and local water, power and fuel supplier requirements. On-site inspection by local, state or third party insurance agents may be required before placing the system in operation.

4. TRIAD recommends that a MASTER POWER DISCONNECT SWITCH AND A FUEL SYSTEM CUT OFF VALVE be installed for each boiler room.

5. NEVER "dry fire" a boiler - operate the burner without full and sufficient water in the boiler.

Verify that the combustion air, breeching, venting, fuel supply, water supply, boiler feed and makeup system, and the condensate tank(s) have been properly installed before attempting to fire the burner.

Burner startup procedures are found in the respective burner manufacturer's instruction book. Be sure to read, understand and heed all warnings.

Improperly installed or maintained boiler systems can cause high levels of Carbon Monoxide, risk of boiler damage or personal injury.

#### **D. INSTALLATION – FIRST, THE BOILERS**

1. TRIAD recommends that all water connections be completed prior to the connection of fuel and electrical power. This will help ensure that a dry fire situation is avoided and reduce the possibility of spraying water over live electrical components. All

fittings should be tight and an appropriate sealant (pipe dope) applied.

2. The safety relief valve should be plumbed in accordance local code and compliant with the manufacturer's recommendations. See the tag attached to the relief valve. The valve should be installed in a vertical upright position with no unnecessary intervening pipe. Under no circumstances should there be a shut off valve or restriction of any kind between the safety valve and the connection. Do not cap or plug the drain hole in the valve body.

Many codes require discharging to the outside atmosphere. Use discharge pipe of size equal or larger than the valve outlet. Use schedule 40 discharge pipe, not schedule 80 nor extra strong pipe to avoid undue stress on the valve. It must allow for easy draining of condensate at or near the valve outlet and must terminate freely to the atmosphere.

3. The LWCO's should be plumbed according to local code and the manufacturer's instructions. Typically the discharge lines must not be restricted or downsized; and should be aimed to reduce the potential exposure of steam and hot water release. The ends of the discharge lines should have no fitting. The relief valve line should be left clearly visible so that if it should operate it will be evident that a discharge has occurred.

4. Flush, connect and test all system water lines.

5. Fill the boiler(s) and verify that the boiler water level is met and there are no leaks in the system.

4. Verify that the water treatment, boiler feed, makeup and condensate systems are properly set to the manufacturers and system design engineer's requirements.

#### **E. NEXT - THE FUEL DELIVERY SYSTEM**

Specific limits and procedures covering fuel line installation, piping, and pressure and leak detection are important to review and understand.

Generally, gas burners should not receive over 0.5 psi (14 inches water column) of gas supply pressure from lines of sufficient volume to avoid an undue pressure drop (see the burner manufacturer's manual). This typically requires the installation of a gas line pressure regulator before the gas train.

Oil supply systems may be one or two line type depending on the burner and system design.

LP systems require pressure regulators and LP specific burners.

Use extreme caution while working on fuel lines to avoid ignition sources. Fuel lines should be checked with an appropriate leak detection fluid or procedure. Many fuel supply companies can provide assistance with appliance connections

Ensure that the fuel supply is shut off at its source before performing any work on the delivery system.

## F. NEXT - THE BURNER

***The burner should not be connected to the fuel supply line until all testing and leak detection of the fuel delivery system is completed***

**STOP: The burner connections warrant special attention. Verify that the recommendations and warnings in the OEM's burner manual are followed.**

1. Verify that the fuel supply is shut off at its source.
2. Verify that the firebox is clear of all foreign material or fuel and that the refractory is intact
3. Mount the burner on the adapter plate supplied with the boiler using the gasket or insulating rope supplied with the burner.
4. Connect the wiring harness to the burner contacts as shown on the wiring diagrams included with the boiler and in this manual.
5. Connect the fuel source to the burner.
6. The burner must be properly adjusted and set up for each site before operation. All burners use both automatic pilot ignition and some form of flame detection. NEVER try to manually light a burner.
7. Make sure all fuel feed valves remain closed.

For proper combustion is it critical to have sufficient fresh air for the burner. **Make sure there is at least one square inch of opening of fresh air for every 3,000 Btu input.** For proper ventilation install two fresh air openings, one 24" from the floor and one at a high level to make sure hot air is exhausted from the boiler room.

If a direct sidewall connection to bring in outside combustion air is installed, make sure the vent is designed for a pressure drop of no greater than .10"

## INSTALLATION

wc. So be aware of length, diameter and elbows.

Do not install any exhaust fans in the boiler room, this can starve the boilers of air resulting in poor combustion, and create a downdraft in the stack.

## G. NEXT - ELECTRICAL CONNECTIONS

**FIRST** – Verify that the line voltage power is off and the Call For Heat control (thermostat) is off.

1. Connect the line voltage service to L1 and L2 terminals in the electrical wiring box on the boiler.
2. Connect the low voltage (thermostat) circuit to the T1 terminals in the wiring box on the boiler.

## H. FEEDWATER PIPING

Feedwater piping is important to provide adequate water supply with properly sized piping. Make sure you follow proper local code requirements.

Use the following diameters for the appropriate boiler.

MBH Input	HP	Inches
400	10	$\frac{3}{4}$
1000	23	1
1700	39	1 $\frac{1}{2}$

Make sure pipe is supported near the pump and is not using the pump as its means of support. Make sure the city water pressure in not above 40 psi when feeding the boiler using a return system. The follow chart shows the steaming rates for Triad boilers.

On the next page is a chart showing the steaming rates for the Triad boiler models.

***When using multiple boilers in a modular setup, Triad highly recommends having a permanently pressurized feedwater loop with fast opening ASCO valves so that water is fed into the boilers in a timely manner.***

Also shown on following pages is recommended near-boiler piping for the 900 and 1600.

## SECTION V

## Recommended Near-Boiler Piping – Series 900 Low Pressure Steam

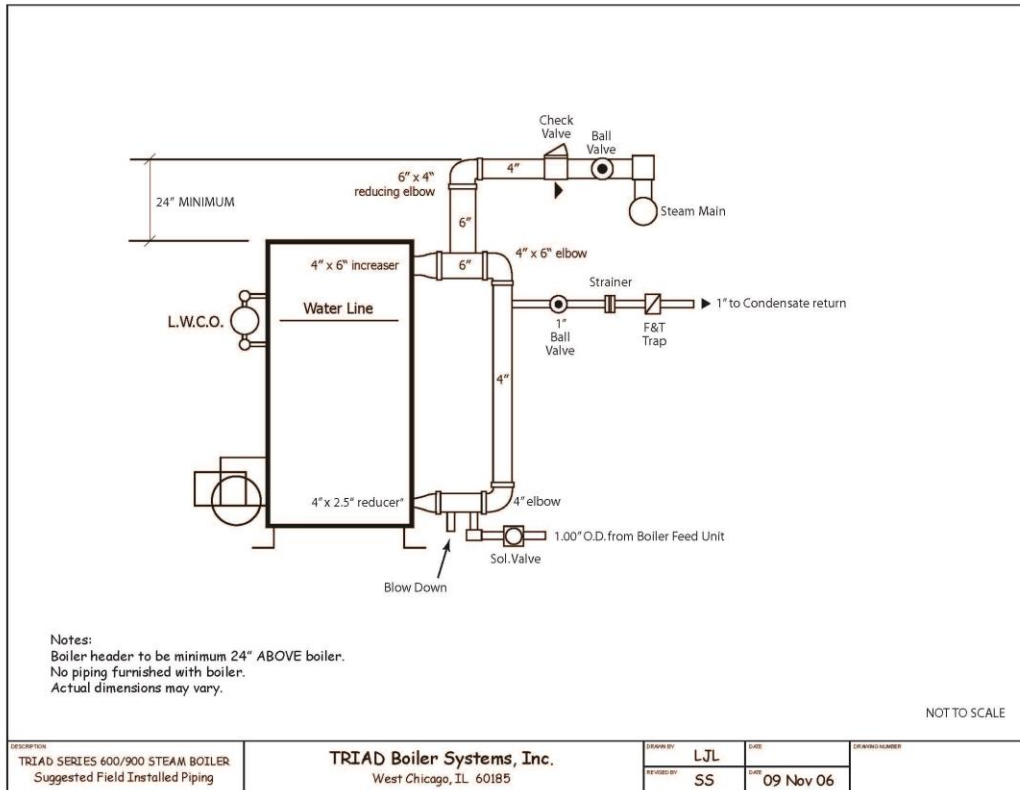

## Series 1600 Low Pressure Steam

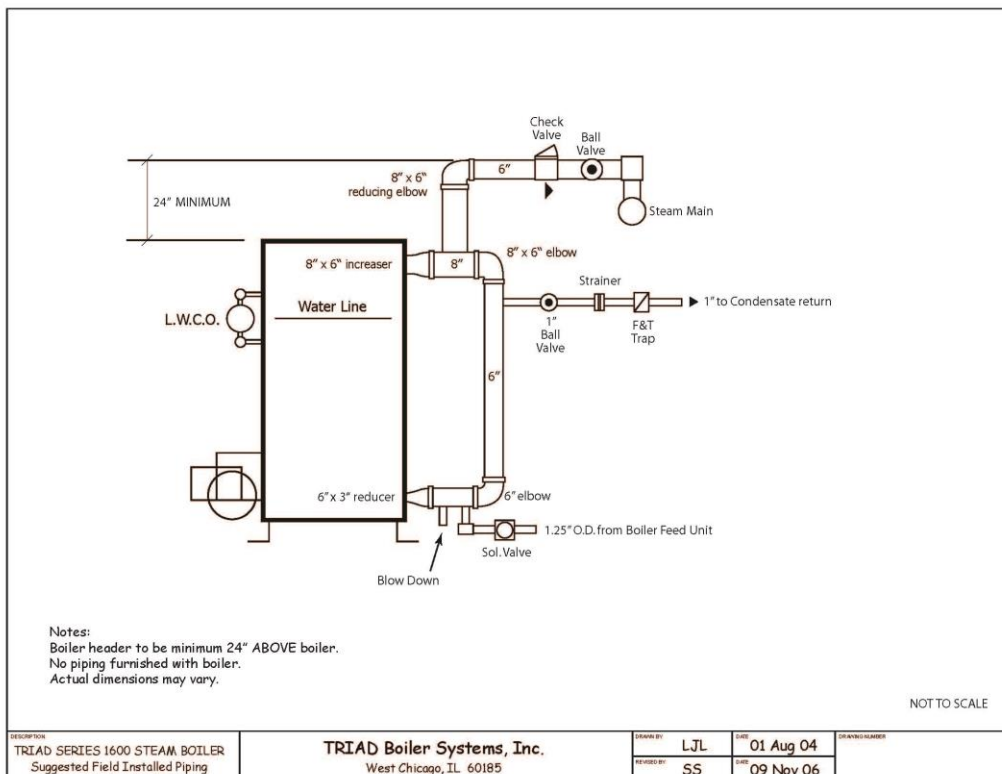

**Feedwater Information –  
Steaming Rates and Loop Characteristics**

	<b>SERIES 300</b>	<b>SERIES 600</b>	<b>SERIES 900</b>	<b>SERIES 1600</b>
Firing rate	375 MBH	600 MBH	1000 MBH	1700 MBH
Steam pounds/hr produced	321	513	845	1454
Make-up Water Required (gallons per refill):	0.95	1.72	1.72	2.6
Steaming Rate before refill starts:	93 seconds	100 seconds	61 seconds	54 seconds
Loop Characteristics (typical): - constantly under pressure - solenoid valves control feed to each boiler	6gpm @ 20psi	9gpm @ 20psi	9gpm @ 20psi	9gpm @ 20psi
Refill Cycle Time – seconds based on loop characteristics	9.5 seconds	11.47 seconds	11.47 seconds	17.41 seconds
Solenoid Valve: (typical with ethylene propylene discs)	8220G5 ASCO 3/4"	8220G7 ASCO 1.0"	8220G7 ASCO 1.0"	8220G7 ASCO 1.0"

The Pressurized Loop mentioned above is most important when setting up a modular steam plant of several boilers to ensure that feedwater/condensate is delivered to the boilers in a timely manner.

## **I. IMMEDIATELY PRIOR TO STARTUP**

Verify that:

- The breeching has no leaks.
- The combustion air requirements are met.
- No combustibles or vapors are present in the boiler room area.
- All ventilation and combustion air openings and louvers are clean and free of debris
- All stack and breeching dampers are set.
- All flue and breeching passages are clear of any fuel accumulations.
- Test the safety relief valve.
- Test the LWCO. ("blow down") valves.
- Confirm that the system design engineer has completed all mandatory code installation requirements including necessary inspections.
- Verify that air separation, water treatment, boiler feed, makeup water and condensate return loop components are operating correctly as per manufacturers' instructions.
- Verify that all operating controls are set.
- Verify that all safety controls are set.
- Verify that the burner pre-purge cycle, ignition and ignition confirmation circuits are functional before opening fuel feed valves.

## **J. START-UP**

After all system and pre-start checks have been completed, apply fuel, power and control signals **as directed in the burner manufacture's manual.**

## **K. IMMEDIATELY AFTER FIRING:**

Monitor the first ignition cycle carefully for proper operation

Continue to monitor initial operations and adjust the burner as required for correct operation. Note the combustion products readings for future performance monitoring and ensure operations are on the correct side of the curve - excess oxygen.

Continue with a normal shutdown. Observe the burner for correct response and physically inspect the burner and firebox sight glass to ensure that the flame has been completely cut off.

Closely monitor several complete cycles to confirm proper operation. Ensure that all of the steps in the burner manufacturer's instructions have been completed.

Complete Operator training. Begin keeping a Maintenance Log -- record all startup readings.

Balance the system to the design engineer's specifications by adjusting flow, control, and temperature settings. Some "trial and error" is inevitable.

Section IV covers typical boiler operating sequences and controls.

Section VII covers Maintenance and Section VIII Troubleshooting (for qualified technical support only).

## **CLEANING THE BOILER (BOIL OUT/SKIMMING)**

New steam boilers need to be thoroughly cleaned before being placed into normal operations. After installation and before the boiler is officially in service the pressure vessel should be cleaned of any oil film, dirt, and other impurities. The boiler should be ready for firing and the operator should be fully familiar with the operation of the boiler and burner and follow instructions contained in those manuals. The operating conditions of all auxiliary equipment should be formally checked out.

Boil outs and skimming the water surface are methods of cleaning a steam boiler and the system to remove oils and contaminants from the water. It is performed by heating the boiler to temperature and then skimming off the top of the water at the water line. New boilers require repetitive cleaning during the first few weeks of continuous operation. Existing boilers need cleaning whenever the water level begins to surge, prime or bubble.

The gauge glass should be dry above the water line and the water line should be stable. Changes in the gauge glass water level or the presence of visible moisture above the water line or water droplets carrying over from the top suggest the need for a good cleaning.

It is usually best to let the boiler operate for several days to clear out the system before doing the initial

cleaning operation. See section VII.

The manual blow-down valves on the LWCO controls should be operated at least 2 to 3 times a day during the first two weeks of boiler operation. After that, manual blow-down should be performed at least daily on all operating boilers – see LWCO manufacturer's instructions and Section VII.

The skim tapping (flange) on the rear of the boiler should be piped with a shut-off valve and discharge line to a suitable drain (local code permitting).

Three possible methods are suggested depending on the conditions, age and size of the systems. .

1. The simplest method is to run the system and dispose all condensate for several days until it runs clear (if allowed by local code). This method is the least effective.

2. Another method, which is more effective is the following:

- A) Run the boiler to a low boil temperature - slightly above 217°F or 2 psig. Then turn the burner off.
- B) Isolate the boiler from the rest of the system and allow the boiler to cool until no pressure is showing on the gauge.
- C) Open the skim tap shut-off valve carefully to “skim” off the top level of water – be careful of flash. Power the boiler feed water solenoid open to replace the water being “skimmed-off”
- D) Capture a sample of the spill into a suitable container about 2 inches across and 9 inches deep and heat it to a boil. If the water foams, surges or forms large bubbles, then dirt and oil remain in the system.

3. A third method is chemical cleaning, which is the most effective method. There are special trademarked chemicals available on the market for boil outs. It is strongly recommended that a water treatment consultant with expertise in boiler water chemistry be available to provide direction as required.

**Failure to completely clean a new boiler will result in wet steam production and erratic boiler performance. The oil in the water will lead to foaming, and surges (“priming”) in the water**

**level, typically visible through the gauge glass.**

You can also refer to the instructions in Section 7 of the ASME Boiler Code for more detail on cleaning pressure vessels.

**Depending on the age and condition of the system, the system may require several cleaning cycles**

# **TRIAD BOILER SYSTEMS, INC.**

## **Section VI**

### **OEM COMPONENT PRODUCT DATA**

It is imperative that the documentation in this section be thoroughly reviewed before placing the boiler in operation.

These materials include specific operating warnings that must be followed for proper boiler operations.

Failure to follow the directions and warnings can result in serious personal injury and/or damage to the boilers and other property.



**IMPORTANT:** It is important to pay special attention to the burner manufacturers Installation and Operation Manual.





**McDonnell & Miller**  
Installation & Maintenance  
Instructions  
MM-217(I)

**Series 150S and 157S**     
(Snap Switch, All Models except 157S-RB-P)

**Low Water Cut-Off/Pump Controllers**  
For Steam Boilers and Other Level Control Applications

**Typical Applications:**

- Primary or secondary pump controller/  
low water fuel cut-off  
for steam boilers
- Motorized valve controller
- Low water cut-off
- High water cut-off
- Alarm actuator

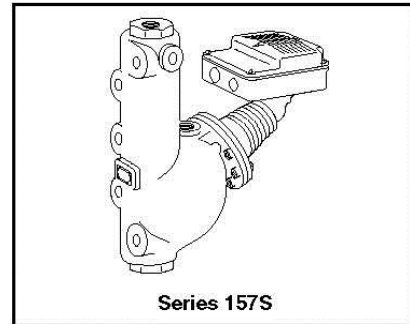
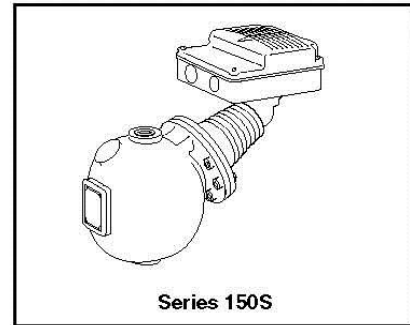

**⚠ WARNING**

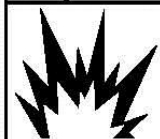

- Before using this product read and understand instructions.
  - Save these instructions for future reference.
  - All work must be performed by qualified personnel trained in the proper application, installation, and maintenance of plumbing, steam, and electrical equipment and/or systems in accordance with all applicable codes and ordinances.
  - To prevent serious burns, the boiler must be cooled to 80°F (27°C) and the pressure must be 0 psi (0 bar) before servicing.
  - To prevent electrical shock, turn off the electrical power before making electrical connections.
  - This low water cut-off must be installed in series with all other limit and operating controls installed on the boiler. After installation, check for proper operation of all of the limit and operating controls, before leaving the site.
  - We recommend that secondary (redundant) Low Water Cut-Off controls be installed on all steam boilers with heat input greater than 400,000 BTU/hour or operating above 15 psi of steam pressure. At least two controls should be connected in series with the burner control circuit to provide safety redundancy protection should the boiler experience a low water condition. Moreover, at each annual outage, the low water cut-offs should be dismantled, inspected, cleaned, and checked for proper calibration and performance.
  - To prevent serious personal injury from steam blow down, connect a drain pipe to the control opening to avoid exposure to steam discharge.
  - To prevent a fire, do not use this low water cut-off to switch currents over 7.4A, 1/3 Hp at 120 VAC or 3.7A, 1/3 Hp at 240 VAC, unless a starter or relay is used in conjunction with it.
- Failure to follow this warning could cause property damage, personal injury or death.

# OPERATION

**Maximum Pressure:** 150 psi (10.5 kg/cm<sup>2</sup>)

## Electrical Ratings

Voltage	Pump Circuit Rating (Amperes)		Pilot Duty
	Full Load	Locked Rotor	
120 VAC	7.4	44.4	345 VA at 120 or 240 VAC
240 VAC	3.7	22.2	

Alarm Circuit Rating	
Voltage	Amps
120 VAC	1
240 VAC	1/2

Motor Horsepower	
Voltage	Hp
120 VAC	1/3
240 VAC	1/3

**Enclosure rating:** NEMA 1 General Purpose

## Settings and Differential Pressures

Values are ± 1/8" (3.2mm).

**Series 150S, 157S**

Pressure	Setting	Approximate Distance Above Cast Line In. (mm)	Differential In. (mm)
<b>0 psi (0 kg/cm<sup>2</sup>)</b>	Pump Off	15/16 (24)	5/16 (8)
	Pump On	5/8 (16)	
	Burner On	5/8 (16)	3/8 (16)
	Burner Off	1/4 (6.4)	
<b>150 psi (10.5 kg/cm<sup>2</sup>)</b>	Pump Off	13/8 (41)	3/4 (19)
	Pump On	5/8 (16)	
	Burner On	7/8 (22)	7/8 (22)
	Burner Off	0 (0)	

**150 psi (10.5 kg/cm<sup>2</sup>) Levels**

**Model 150S-MD, and 157S-MD**

Pressure	Setting	Approximate Distance Above Cast Line In. (mm)	Differential In. (mm)
<b>0 psi (0 kg/cm<sup>2</sup>)</b>	Pump Off	15/16 (24)	3/8 (16)
	Pump On	9/16 (14)	
	Burner Off	0 (0)	N/A
<b>150 psi (10.5 kg/cm<sup>2</sup>)</b>	Pump Off	17/16 (37)	3/4 (19)
	Pump On	11/16 (17)	
	Burner Off	- 3/8 (-16)	N/A

**150 psi (10.5 kg/cm<sup>2</sup>) Levels**

## Settings and Differential Pressures (continued)

Values are  $\pm 1/8$ " (3.2mm).

Model 158S			
Pressure	Setting	Approximate Distance Above Cast Line In. (mm)	Differential In. (mm)
0 psi (0 kg/cm <sup>2</sup> )	Motorized Valve Closed	15/16 (24)	5/16 (8)
	Motorized Valve Open	5/8 (16)	
	Burner On	5/8 (16)	3/8 (16)
	Burner Off	1/4 (6.4)	
150 psi (10.5 kg/cm <sup>2</sup> )	Motorized Valve Closed	13/8 (41)	3/4 (19)
	Motorized Valve Open	5/8 (16)	
	Burner On	7/8 (22)	7/8 (22)
	Burner Off	0 (0)	

### 150 psi (10.5 kg/cm<sup>2</sup>) Levels

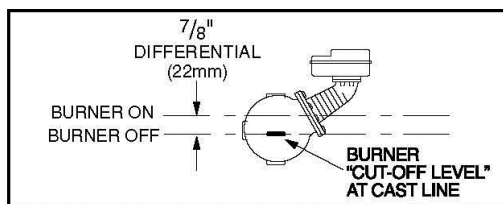
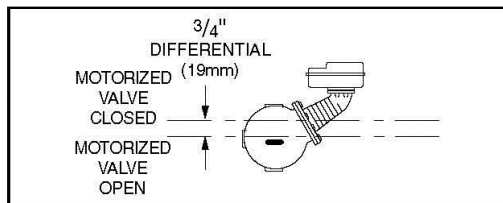
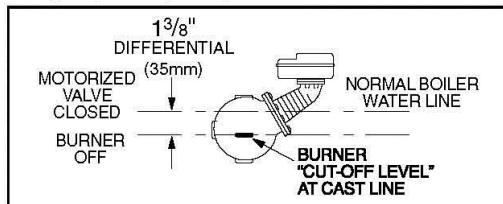

NOTE: Due to the slower operation of some motorized valves, complete valve opening or closing will occur at slightly different levels than indicated above.

### Model 158S-MD

Pressure	Setting	Approximate Distance Above Cast Line In. (mm)	Differential In. (mm)
0 psi (0 kg/cm <sup>2</sup> )	Pump Off	15/16 (24)	3/8 (16)
	Pump On	9/16 (14)	
	Burner Off	0 (0)	N/A
150 psi (10.5 kg/cm <sup>2</sup> )	Pump Off	17/16 (37)	3/4 (19)
	Pump On	11/16 (17)	
	Burner Off	- 3/8 (-16)	N/A

### 150 psi (10.5 kg/cm<sup>2</sup>) Levels

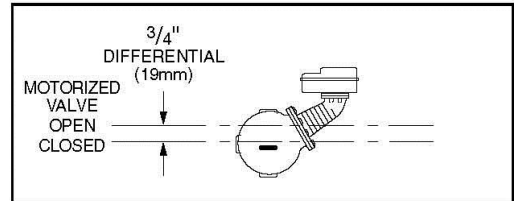
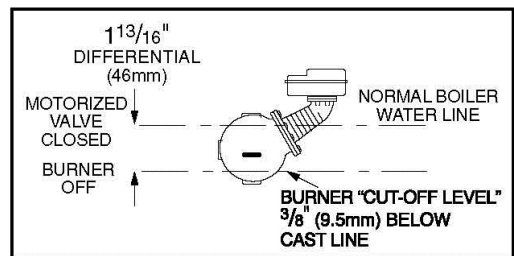

NOTE: Due to the slower operation of some motorized valves, complete valve opening or closing will occur at slightly different levels than indicated above.

**Settings and Differential Pressures (continued)**

Values are  $\pm 1/8"$  (3.2mm).

<b>Model 159S</b>			
<b>Pressure</b>	<b>Setting</b>	<b>Approximate Distance Above Cast Line In. (mm)</b>	<b>Differential In. (mm)</b>
<b>0 psi (0 kg/cm<sup>2</sup>)</b>	Pump #1 Off	15/16 (24)	5/16 (8)
	Pump #1 On	5/8 (16)	
	Pump #2 Off	5/8 (16)	3/8 (16)
	Pump #2 On	1/4 (6.4)	
<b>150 psi (10.5 kg/cm<sup>2</sup>)</b>	Pump #1 Off	1 3/8 (41)	3/4 (19)
	Pump #1 On	5/8 (16)	
	Pump #2 Off	7/8 (22)	7/8 (22)
	Pump #2 On	0 (0)	

**150 psi (10.5 kg/cm<sup>2</sup>) Levels**

1 3/8" DIFFERENTIAL (35mm)

PUMP #1 OFF

PUMP #2 ON

NORMAL BOILER WATER LINE

PUMP #2 ON AT CAST LINE

3/4" DIFFERENTIAL (19mm)

PUMP #1 OFF

PUMP #1 ON

NORMAL BOILER WATER LINE

7/8" DIFFERENTIAL (22mm)

PUMP #2 OFF

PUMP #2 ON

NORMAL BOILER WATER LINE

PUMP #2 ON AT CAST LINE

## INSTALLATION

### TOOLS NEEDED:

Two (2) pipe wrenches, one (1) flathead screw driver, and pipe sealing compound.

**IMPORTANT:** Follow the boiler manufacturer's instructions along with all applicable codes and ordinances for piping, blow down valve and water gauge glass requirements.

### STEP 1 - Determine the Elevation at Which the Low Water Cut-Off/Pump Controller Must be Installed

If the control will be the **primary low water fuel cut-off**, size the steam (top) and water (bottom) equalizing pipe lengths so that the horizontal cast line on the body is **1 3/8" (35mm) below the boiler's normal water level, but not lower than the lowest, safe permissible water level, as determined by the boiler manufacturer.**

OR

If the control will be the **secondary low water fuel cut-off**, size the steam (top) and water (bottom) equalizing pipe lengths so that the horizontal cast line on the body is **at or above the lowest, safe permissible water level, as determined by the boiler manufacturer.**

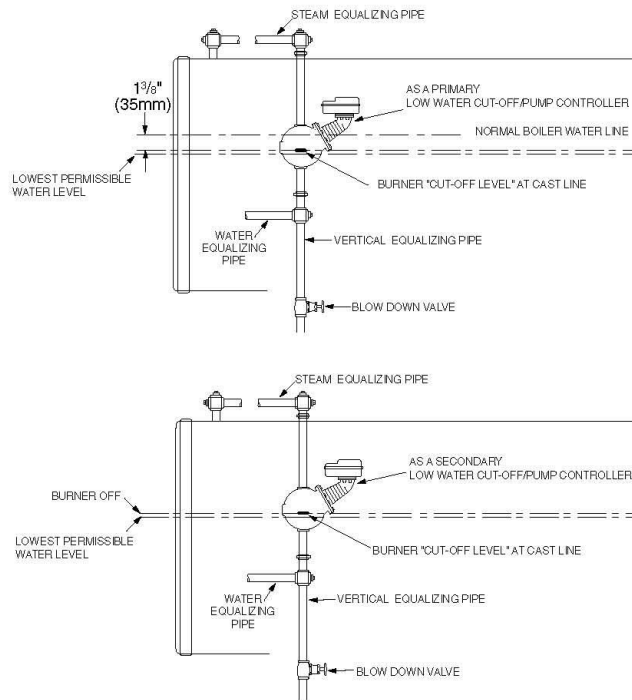

### STEP 2 - Installing the Low Water Cut-Off

- Using a pipe wrench, unscrew the plastic float blocking plug (A) from the low water cut-off body (B).

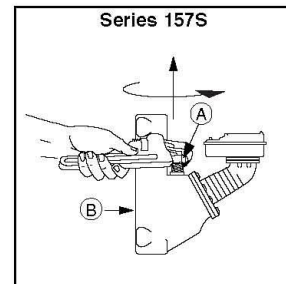
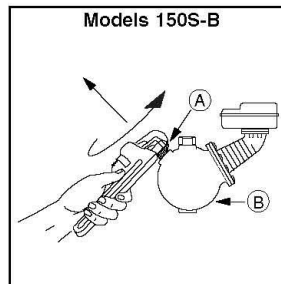
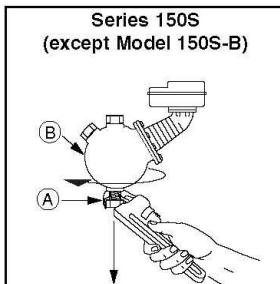

- b. For Model 150S-B and Series 157S**  
(For all other models, proceed to Step 3).

Screw the 3/4" NPT steel plug (C) (provided) in tapping (A).

**CAUTION**

The plug must be reinstalled before control is shipped installed on the boiler, and removed when boiler is installed after shipment. Failure to follow this caution may damage float and operating mechanism.

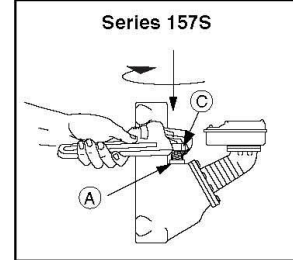
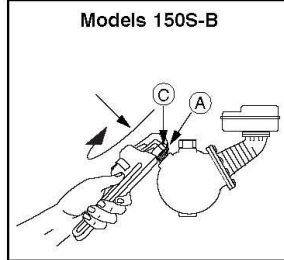

- c. Mount and pipe the low water cut-off (D) on a vertical equalizing pipe (E) at the required elevation level, as determined in Step 1.**

Install a full ported blow down valve (G) directly below the lower cross of the water equalizing pipe (F).

**Note:** 1" NPT tapings are provided, with the exception of some 157 and 157S models which are 1 1/4" NPT.

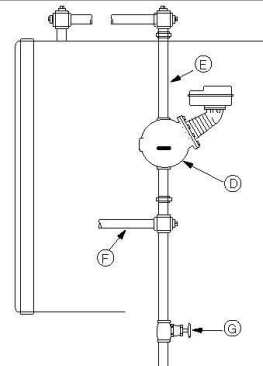

**STEP 3 - Installing a Water Gauge Glass (Required on all steam boilers)**

- a. Install a water column (H) (not included with product) for all models except Series 157S (with integral water column).**

- b. Install a water gauge glass (J).**  
**Note:** Gauge glass and tri-cocks not included with product.

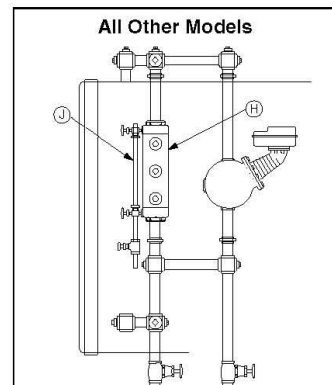
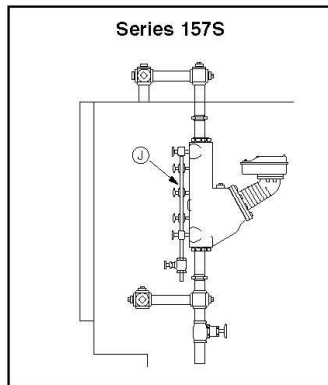

## STEP 4 - Electrical Wiring

### WARNING



- To prevent a fire, do not use this product to switch currents over 7.4A, 1/3 Hp at 120 VAC or 3.7A, 1/3 Hp at 240 VAC, unless a starter or relay is used in conjunction with it.

- To prevent electrical shock, turn off the electrical power before making electrical connections.

- This low water cut-off must be installed in series with all other limit and operating controls installed on the boiler. After installation, check for proper operation of all of the limit and operating controls, before leaving the site.



- Modification of the switch assembly before or after installation could cause damage to the boiler and/or boiler system.

Failure to follow this warning could cause electrical shock, an explosion and/or a fire, which could result in property damage, personal injury or death.

### Switch Operation

#### For all Models except 158S and 159S

Boiler feed pump off,  
burner on, alarm off.



Boiler feed pump on,  
burner on, alarm off.



Boiler feed pump on,  
burner off, alarm on.



#### For Model 158S

Motorized valve closed,  
burner on, alarm off.



Motorized valve open,  
burner on, alarm off.



Motorized valve open,  
burner off, alarm on.



#### For Model 159S

Pump #1 off,  
pump #2 off.



Pump #1 on,  
pump #2 off.



Pump #1 on,  
pump #2 on.



- Using a flathead screwdriver, remove the junction box cover (K).

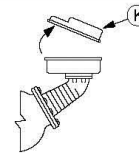

b. Following the appropriate wiring diagram, (refer to page 9) based on your application requirements, and using BX armored cable or Thinwall electrical metal tubing connector fittings, make electrical connections to the junction box (L).

**IMPORTANT:** There must be a minimum space of 1/2" (13mm) between connector fittings and electrical live metal parts.

**Snap Switches (Series 150S and 157S)**

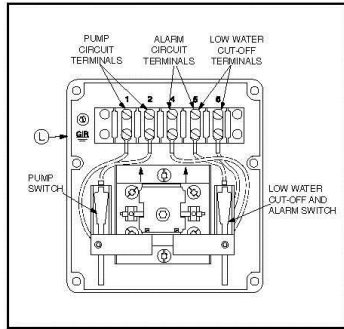

**Automatic Reset  
(All models except 158S and 159S)**

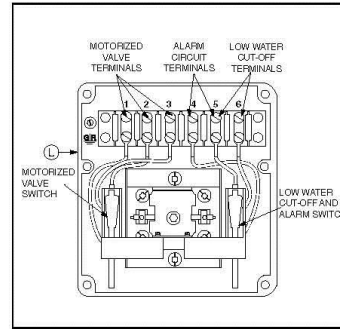

**Automatic Reset  
Model 158S**

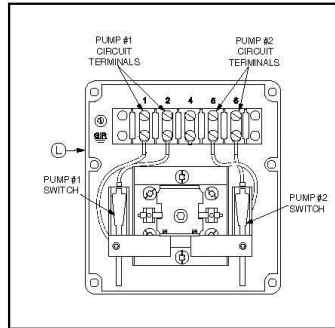

**Automatic Reset  
Model 159S**

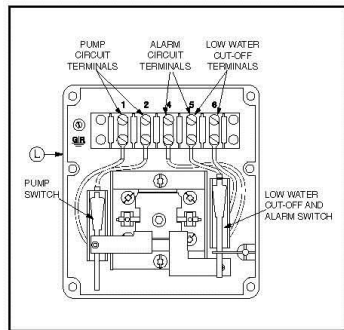

**Manual Reset  
(All models except 158S)**

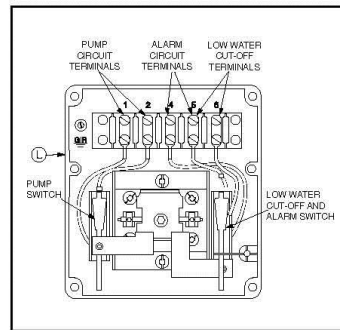

**Manual Reset  
Model 158S-M**



## WIRING DIAGRAMS

For Motorized Valves, refer to the valve manufacturer's wiring instructions.

### Low Water Cut-Off Only

1. Main Line Switch - For burner circuits within the switch's electrical rating.
2. Pilot Switch - To holding coil of a starter when the burner circuit exceeds the switch's electrical rating.

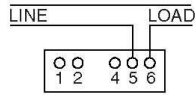

OR

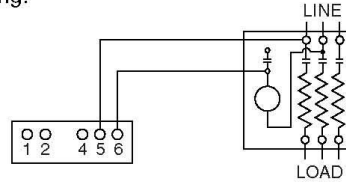

### Pump Control Only

1. Install a starter or relay in pump control circuit, as shown, to prevent damage to snap switch and help insure proper switch/control operation. Failure to do so may shorten the life of the switch when actual amperage exceeds switch rating.

**NOTE:** For Model 159S, use terminals 5 and 6 from starter or relay for pump # 2.

2. Connect wires from holding coil of pump starter or relay to terminals 1 and 2 as shown.

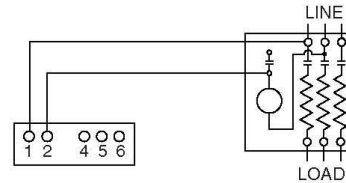

**NOTE:** To help insure most effective operation, balance boiler feed pump(s) to deliver required water feeder rate to match boiler steaming requirements.

### Alarm Circuit Only

1. Low Water Alarm

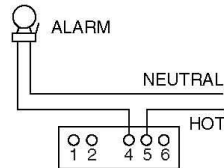

2. High Water Alarm

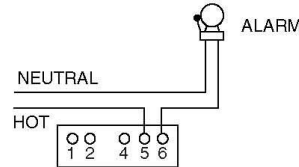

OR

### Combination Pump Control, Low Water Cut-Off and Alarm

1. Main Line Switch - For burner circuits within the switch's electrical rating.

2. Pilot Switch - To holding coil of a starter when the burner circuit exceeds the switch's electrical rating.

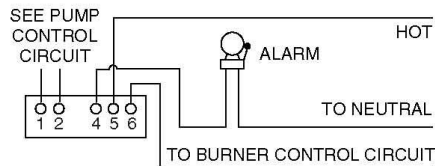

OR

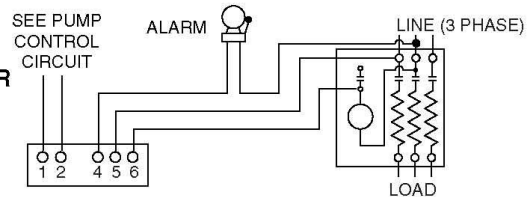

6. Re-attach the junction box cover (K).

**Note:**  
Cover must be installed correctly as shown

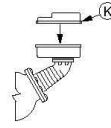

## STEP 5 - Testing

This control is factory calibrated for specific applications. The following testing procedure is only meant to serve as a verification of proper operating sequence. Dimensions provided are typical for a boiler not being fired and/or not at pressure. Actual operating ranges are shown on page 2 in the "Operation" section.

**IMPORTANT:** Follow the boiler manufacturer's start-up and operating instructions along with all applicable codes and ordinances. **Note:** Water levels stated below are only for 150 psi (10.5 kg/cm<sup>2</sup>) operation.

- a. Turn on the electric power to the boiler. With the boiler empty the pump should go on and the burner must remain off.

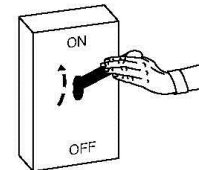

### WARNING



If the burner comes on, immediately turn the boiler off and make the necessary corrections.



Failure to follow this warning could cause an explosion or fire and result in property damage, personal injury or death.

- b. The boiler should begin to fill with water. Watch the gauge glass (J) until the water level reaches approximately  $\frac{7}{8}$ " (22mm) above the horizontal cast line (M) on the low water cut-off.

**IMPORTANT:** If water does not start filling the boiler, immediately turn off the the boiler and make the necessary corrections.

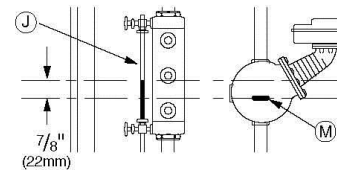

c. **For automatic reset models only.** When the water level reaches approximately  $\frac{7}{8}$ " (22mm) above the horizontal cast line (lower for MD models) the burner should come on (pump #2 should shut off with Model 159S).

OR

**For manual reset models only.** When the water level reaches approximately  $\frac{7}{8}$ " (22mm) above the horizontal cast line press the reset button (N). The burner should then come on.

Snap Switch Models

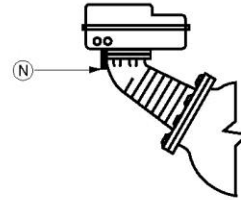

d. Continue watching the gauge glass (J) to see that the water continues to rise to approximately  $1\frac{3}{8}$ " (35mm) ( $1\frac{7}{16}$ " (37mm) for MD models) above the horizontal cast line (M). The pump should shut off (the motorized valve should close with Models 158 and 158S, or with Models 159 and 159S, pump #1 should shut off).

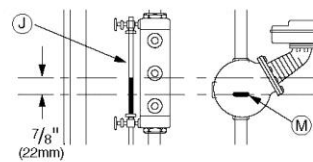

**CAUTION**



To prevent serious personal injury from steam pipe blow down, connect a pipe to avoid exposure to steam discharge.

Failure to follow this caution could cause personal injury.

e. Blow down the control when the water in the boiler is at its normal level and the burner is on. Follow Blow Down Procedure found in Maintenance Section on the last page of these instructions.

**INSTALLATION COMPLETE**

# L4079A,B,W PressureTrol® Limit Control

PRODUCT DATA



## FEATURES

- L4079A has two ganged spst switches; breaks two circuits (may be both sides of the power supply) simultaneously.
- L4079B has one spst switch.
- L4079W is the same as L4079B, but with seals for oil applications.
- MICRO SWITCH® snap-acting switches are visible through transparent cover.
- Switches open automatically, but must be reset manually.
- Trip-free reset mechanisms do not permit the limiting role of the PressureTrol® Control to be defeated by jamming the reset lever.
- Control does not need leveling.
- The L4079 is unaffected by moderate vibration.

## APPLICATION

The L4079A,B, and W PressureTrol® Limit Controls are high pressure limit switches which break electrical circuits when pressure rises to a preset value.

The L4079A and B can be used with steam, air, noncombustible gases, and fluids noncorrosive to the sensing element.

L4079W is for use on oil burner systems.

## Contents

Application .....	1
Features .....	1
Specifications .....	2
POUR COMMANDER .....	2
French .....	
Installation .....	3
Wiring .....	3

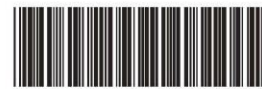

60-2156-2

## SPECIFICATIONS

Models: Pressure and Electrical Specifications: See Table 1.

Table 1. Pressure and Electrical Ratings.

Model Number	Range		Maximum Diaphragm Pressure		Ratings in Amperes			
					120 Vac		240 Vac	
	psi	kPa	psi	kPa	Full Load	Locked Rotor	Full Load	Locked Rotor
L4079A <sup>a</sup> and L4079B <sup>b</sup>	2 to 15	15 to 100	25	170	9.8	58.8	4.9	29.4
	5 to 50	35 to 350	85	590	9.8	58.8	4.9	29.4
	10 to 150	70 to 1035	225	1550	9.8	58.8	4.9	29.4
L4079B1066 <sup>b</sup>	20 to 300	140 to 2070	350	2410	9.8	58.8	4.9	29.4
L4079W1000 <sup>b</sup>	10 to 150	70 to 1035	225	1550	9.8	58.8	4.9	29.4

<sup>a</sup> Ratings apply to each of two separate circuits.

<sup>b</sup> One circuit only.

### Switching Action:

L4079A—Snap-switch. Breaks two circuits automatically on pressure rise. Each circuit must be manually reset.

L4079B,W—Snap-switch. Breaks one circuit automatically on pressure rise. Circuit must be manually reset.

**Adjustment means:** External adjustment screw. Scale is calibrated in psi and kPa.

**Maximum Ambient Temperature:** 150°F (66°C).

### Mounting Means:

Pipe fitting—1/4-18 NPT. Steam trap for mounting furnished on some models. These devices may be either boiler mounted directly to a boiler fitting, or may be surface mounted, such as on a wall, by using the knockouts in the case.

### Approvals:

Underwriters Laboratories Inc. (UL) Listed: File No. MP466, Guide No. MBPR.

Canadian Standards Association (CSA): File No. LR95329, Certificate No. 1720340

### Accessories:

14026 Steam Trap.

33312B Knurled adjustment knob.

**Dimensions:** See Fig. 1.

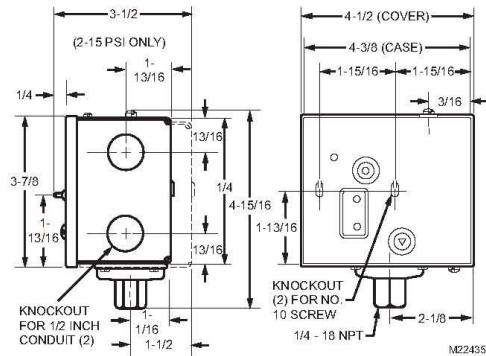

Fig. 1. L4079A,B,W PressureTrol® Limit Control dimensions in inches.

## ORDERING INFORMATION

When purchasing replacement and modernization products from your TRADELINE® wholesaler or distributor, refer to the TRADELINE® Catalog or price sheets for complete ordering number.

If you have additional questions, need further information, or would like to comment on our products or services, please write or phone:

1. Your local Honeywell Automation and Control Products Sales Office (check white pages of your phone directory).
2. Honeywell Customer Care  
1885 Douglas Drive North  
Minneapolis, Minnesota 55422-4386

In Canada—Honeywell Limited/Honeywell Limitée, 35 Dynamic Drive, Scarborough, Ontario M1V 4Z9.

International Sales and Service Offices in all principal cities of the world. Manufacturing in Australia, Canada, Finland, France, Germany, Japan, Mexico, Netherlands, Spain, Taiwan, United Kingdom, U.S.A.

## INSTALLATION

### When Installing This Product...

1. Read these instructions carefully. Failure to follow them could damage the product or cause a hazardous condition.
2. Check on the ratings given in the instructions and marked on the product to make sure the product is suitable for your application.
3. Installer must be a trained, experienced service technician.
4. After installation is complete, check out the product operation as provided in these instructions.

### Location

PressureTrol® Limit Controllers must be mounted above the water line in steam boilers. They can be mounted alongside the pressure gauge, at a remote location, in a fitting provided by the boiler manufacturer, or in special mountings on low-water cutoffs.

### Mounting

See Fig. 1 for mounting dimensions.

A steam trap must always be connected between the PressureTrol® unit and the boiler. The steam trap prevents boiler scale and corrosive vapors from attacking the diaphragm.

### Pressure Gauge Mounting:

To mount the limit control beside a pressure gauge, remove the gauge and install in its place a steam trap with a tee on top. Mount the PressureTrol® unit and pressure gauge on the side of the tee by means of nipples and elbows.

### Remote Mounting:

If excessive vibration seems likely to affect the operation of the control, it may be located remotely, as long as all piping is suitable and properly pitched to drain all condensation back to the boiler.

### Boiler Mounting:

If it is not convenient to mount the control adjacent to the pressure gauge, install a steam trap at a location on the boiler recommended by the boiler manufacturer and screw the unit directly to the steam trap.

## WIRING

### WARNING

**Electrical Shock Hazard.**  
Can cause severe injury, death or property damage. Disconnect the power supply before beginning wiring. More than one power supply disconnect may be required.

All wiring must comply with local codes and ordinances. See Fig. 2 for internal schematics and wiring.

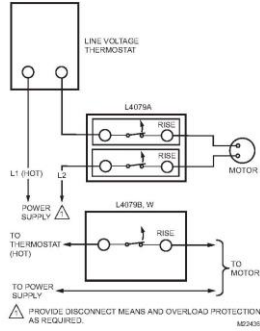

Fig. 2. Schematics and wiring. L4079A breaks both sides of power supply; L4079B,W breaks hot side only.

### Setting

To set the control, turn the pressure adjusting screw (see Fig. 3) until the pressure setting indicator on the front of the case is in line with the required control pressure setpoint. The indic setting is the point at which the switch breaks contact.

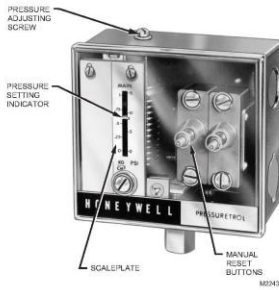

Fig. 3. Controls and indicators on L4079A, L4079B,W is same except for having only one reset button.

### Manual Resetting

When the circuits have broken automatically, they must be manually reset. After the pressure returns to normal, manually reset by depressing the manual reset button(s) firmly and releasing. The circuit is not complete until the reset button is released. The trip-free manual reset mechanism prevents the limit controller from operating as an automatic controller (self-resetting) even if the manual reset button has been tied down.

### CHECKOUT

After the control has been installed and wired, test as follows:

Note the boiler pressure by checking the boiler pressure gauge (boiler pressure should be near the middle of the PressureTrol® pressure scale to perform this test properly).

Rotate the PressureTrol® pressure adjusting screw (see Fig. 3) until the pressure setting indicator on the front of the case corresponds to the boiler pressure gauge reading.

The limit control should break the control circuit(s) when the boiler pressure gauge reading equals or slightly exceeds the PressureTrol® pressure setting.

If the limit control is operating properly, manually reset it and adjust the pressure adjusting screw until the pressure setting indicator is in line with the required limit setpoint.

### Automation and Control Solutions

Honeywell International Inc.  
1985 Douglas Drive North  
Golden Valley, MN 55422  
customer.honeywell.com

Honeywell Limited-Honeywell Limitée  
35 Dynamic Drive  
Scarborough, Ontario M1V 4Z9

© U.S. Registered Trademark  
© 2006 Honeywell International Inc.  
60-2156--2 C.H. Rev. 02-06

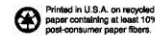

# Honeywell

## L404A-D,F; L604A,L,M Pressuretrol® Controllers

L404 and L604 Pressuretrol® Controllers are line voltage pressure controllers that provide operating control, automatic limit protection, or manual reset limit protection for pressure systems of up to 300 psi (21.1 kg/cm<sup>2</sup> or 2068 kpa).



- Can be used with steam, air, non-combustible gases, or fluids non-corrosive to the pressure sensing element.
- Stainless steel diaphragm (except 300 psi [21.1 kg/cm<sup>2</sup> (2068 kPa)] models) also allows use with ammonia, oxygen, distilled water, and similar media.
- L404B is recommended for supervision of atomizing medium pressure in oil burner systems.
- Models are available with spst, spdt, or dpst switching and in variety of operating ranges.
- Dustproof, trouble-free mercury switches (all models except L404F, which has snap-acting switch).
- Automatic reset models have adjustable, subtractive differential (except L604M).
- Trip-free mechanism on manual reset models assures that limit function of controller cannot be defeated by jamming reset lever.
- Screw adjustments made on top of case.
- Scaleplates marked in English (psi) and Metric (kg/cm<sup>2</sup>) units.
- L404F models available with European enclosure, British Standard Pipe Threads, ground screw, and scaleplates marked in kg/cm<sup>2</sup> and either psi or kPa.
- Clear plastic cover on case to observe pressure settings and switch action.
- Leveling indicator visible through cover.
- Hexagonal fitting with 1/4-18 NPT internal threads for direct mounting to 14026 Steam Trap (siphon loop).
- Surface mount is available using screws through holes (knockouts) in case backing.

### CONTENTS

Specifications .....	2
Ordering Information .....	2
Installation .....	5
Setting and Checkout .....	8
Service Information .....	10

L. Z. • Rev. 3-95 • ©Honeywell Inc. 1995



60-2150-10

## Specifications

### TRADELINE® MODELS

TRADELINE® models are selected and packaged to provide ease of stocking, ease of handling, and maximum replacement value. Specifications of TRADELINE® controls are the same as those of standard models except as noted below.

#### TRADELINE® MODELS AVAILABLE:

L604A Pressuretrol® Controllers—Available in 2 to 15, 5 to 50, 10 to 150, and 20 to 300 psi (.14 to 1.1 kg/cm<sup>2</sup> [14 to 103 kPa], .4 to 3.5 kg/cm<sup>2</sup> [34 to 345 kPa], .7 to 10.6 kg/cm<sup>2</sup> [69 to 1034 kPa], and 1.4 to 21.0 kg/cm<sup>2</sup> [138 to 2068 kPa]).

ADDITIONAL FEATURES: TRADELINE® pack with cross-reference label.

### STANDARD MODELS

MODELS: L404A-D,F and L604A,L,M Pressuretrol® Controllers. See Table 1. A 14026 Steam Trap (siphon loop)

is available, except where noted in Table 1. The steam trap is necessary for boiler installations.

SWITCH(ES): Mercury switch(es) in all models except the L404F, which has a Micro Switch snap-acting switch.

PRESSURE SENSING ELEMENT: Stainless steel diaphragm (brass bellows in 300 psi [21.1 kg/cm<sup>2</sup>, (2068 kPa)] models).

MAXIMUM AMBIENT TEMPERATURE: 150°F (66°C).

MINIMUM AMBIENT TEMPERATURE: Minus 35°F (minus 37°C); also refer to the note in the Location and Mounting section.

ADJUSTMENT MEANS: Screws on top of controller case. Scales are marked in psi and kPa.

ELECTRICAL CONNECTIONS: Internal screw terminals; hole in side of case for 1/2 in. conduit.

MOUNTING MEANS: Hexagonal fitting on diaphragm has 1/4-18 NPT internal threads for mounting on a pipe or steam trap (siphon loop). Also can be surface-mounted using screws through two holes (knockouts) in back of case.

## Ordering Information

When purchasing replacement and modernization products from your TRADELINE® wholesaler or distributor, refer to the Tradeline Catalog or price sheets for complete ordering number, or specify—

1. Order number (TRADELINE® model, if desired).
2. Operating range (see Table 1).
3. Model without steam trap, if desired and available (see Table 1, Note b).
4. Optional specifications, if desired (see Table 1).
5. Replacement parts, if desired.
6. Accessories, if desired.

If you have additional questions, need further information, or would like to comment on our products or services, please write or phone:

1. Your local Home and Building Control Sales Office (please check the white pages of your phone directory).
2. Home and Building Control Customer Relations  
Honeywell, 1885 Douglas Drive North  
Minneapolis, Minnesota 55422-4386

In Canada—Honeywell Limited/Honeywell Limitée, 35 Dynamic Drive, Scarborough, Ontario M1V 4Z9. International Sales and Service Offices in all principal cities of the world. Manufacturing in Australia, Canada, Finland, France, Germany, Japan, Mexico, Netherlands, Spain, Taiwan, United Kingdom, U.S.A.



TABLE 1—MODELS AVAILABLE.

Model	Switching Action on Pressure Rise to Setpoint	Operating Ranges <sup>a</sup>			Midscale Subtractive Differential <sup>a</sup> (Adjustable)			Maximum Surge Pressure		
		psi	kg/cm <sup>2</sup>	kPa	psi	kg/cm <sup>2</sup>	kPa	psi	kg/cm <sup>2</sup>	kPa
L404A	spst, breaks circuit	2 to 15 <sup>b,c</sup>	.14 to 1.0	14 to 103	2 to 6	.14 to .41	14 to 4	50	3.5	345
		5 to 50	.35 to 3.5	34 to 345	4 to 12	.28 to .82	127 to 83	85	6.0	586
		10 to 150 <sup>b</sup>	.66 to 10.6	69 to 1034	8 to 16	.56 to 1.10	55 to 110	225	15.8	1550
		20 to 300 <sup>d</sup>	1.4 to 21.0	138 to 2068	15 to 40	1.04 to 2.76	103 to 276	500	35.2	3445
L404B <sup>l</sup>	spst, makes circuit	2 to 15 <sup>d, c,e,f</sup>	.14 to 1.1	14 to 103	2 to 6	.14 to .41	14 to 41	50	3.5	345
		5 to 50	.35 to 3.5	24 to 345	4 to 12	.28 to .82	27 to 83	85	6.0	586
		10 to 150 <sup>e,b</sup>	.66 to 10.6	69 to 1034	8 to 16	.56 to 1.10	55 to 110	225	15.8	1550
		20 to 300 <sup>d</sup>	1.4 to 21.0	138 to 2068	15 to 40	1.04 to 2.76	103 to 276	500	35.2	3445
L404C	spst, breaks circuit	2 to 15	.14 to 1.0	14 to 103	manual reset (fixed, subtractive differential)			50	3.5	345
		5 to 50	.35 to 3.5	34 to 345	85	6.0	586			
		10 to 150	.66 to 10.6	69 to 1034	225	15.8	1550			
		20 to 300 <sup>d</sup>	1.4 to 21.0	138 to 2068	500	35.2	3445			
L404D	spst, makes circuit	2 to 15	.14 to 1.0	14 to 103	manual reset <sup>g</sup> (fixed, subtractive differential)			50	3.5	345
		10 to 150	.66 to 1.0	69 to 1068	225	15.8	1550			
L404F	spdt snap-acting switch, <sup>h</sup> makes R-W, breaks R-B	2 to 15	.14 to 1.0	14 to 103	2 to 6	.14 to .41	14 to 41	50	3.5	345
		5 to 50 <sup>l</sup>	.35 to 3.5	34 to 345	6 to 14	.41 to .97	41 to 97	85	6.0	586
		10 to 150	.66 to 10	69 to 1034	10 to 22	.69 to 15.2	60 to 152	225	15.8	1550
		20 to 300 <sup>d</sup>	1.4 to 21.0	138 to 2068	20 to 50	1.4 to 3.5	138 to 345	500	35.2	3445
L604A	2 isolated spst circuits, or 1 spdt, <sup>j</sup> makes R1-W, breaks R2-B	2 to 15 <sup>c</sup>	.14 to 1.0	14 to 103	2 to 6	.14 to .41	14 to 41	25	1.8	172
		5 to 50	.35 to 3.5	34 to 345	4 to 12	.28 to .82	27 to 83	85	6.0	586
		10 to 150	.66 to 10	69 to 1034	8 to 16	.56 to 1.10	55 to 110	225	15.8	1550
		20 to 300 <sup>d</sup>	1.4 to 21.0	138 to 2068	15 to 40	1.04 to 2.76	103 to 276	500	35.2	3445
L604L	spdt circuit makes R-W, breaks R-B	2 to 15	.14 to 1.0	14 to 103	manual reset <sup>g</sup> (fixed, subtractive differential)			25	1.8	172
L604M	spdt circuit makes R-W, breaks R-B	10 to 150	.66 to 10.1	69 to 1034	fixed: 3.5 psi (24.1 kPa)			225	15.8	1550

- <sup>a</sup> Scaleplates are marked in both psi and kg/cm<sup>2</sup>
- <sup>b</sup> Model available with special fixed low differential. Switch rated for 0.5A at 120 Vac.
- <sup>c</sup> L404A,B and L604A models are available with 1 to 6 psi midscale subtractive differential in 2 to 15 psi models.
- <sup>d</sup> Brass bellows replaces stainless steel diaphragm. Not suitable for use with ammonia, oxygen, or other corrosive materials.
- <sup>e</sup> Model available with minimum operating pressure of 1.25 psi (0.09 kg/cm<sup>2</sup> or 8.62 kPa) and minimum subtractive differential of 0.5 psi (0.035 kg/cm<sup>2</sup> or 3.45 kPa).
- <sup>f</sup> Model available with special fixed low differential. Switch rated for 0.5A at 120 Vac.
- <sup>g</sup> L404C,D and L604L models are designated as Manual Reset 2 controllers; the trip-free reset mechanism does not permit the controller to function as an automatic-reset device when the manual reset lever is held in the reset position. The subtractive differential is fixed at the minimum value of the adjustable differential of the L404A for each corresponding operating range.
- <sup>h</sup> L404F only; all other models have mercury switches.
- <sup>i</sup> Model available with sealed bell crank adjustment.
- <sup>j</sup> Spst switches operate in unison; spdt action when jumper is installed between R1 and R2.
- <sup>k</sup> Also recommended for supervision of atomizing medium pressure (air or steam) in an oil burner system.

SWITCH CONTACT RATING (in amperes at 50/60 Hz):

Model	Load	120 Vac	240 Vac	120 Vdc	240 Vdc
L404A	Full Load	8.0	5.1	2.4	1.2
	Locked Rotor	48.0	30.6	24.0	12.0
	Noninductive <sup>g</sup>	10.0	5.0	5.0	2.0
L604A,L <sup>b</sup>	Full Load	8.0	5.1	2.0	1.0
	Locked Rotor	48.0	30.6	20.0	10.0
	Noninductive	10.0	5.0	8.0	4.0
L604M	Full Load	1.0	0.5	1.0	0.5

- <sup>a</sup> L404F (snap-acting) does not have non-inductive or dc ratings.
- <sup>b</sup> L604A and L have also been tested (and listed by Underwriters Laboratories Inc.) and breaking (not making) a load with a total rating of 9.8 A full load, plus 360 VA ignition, plus 250 VA pilot duty at 120 Vac.

L404A-D,F; L604A,L,M  
SPECIFICATIONS

DIMENSIONS: See Fig. 1. See Fig. 2 for mounting steam trap (siphon loop).

WEIGHT: 2 IBC. (0.91 kg).

FINISH: Gray.

APPROVALS:

Underwriters Laboratories Inc. listed (L404A,B,C,D,F; L604A,L,M only): file no. MP466, vol.10; guide no. MBPR.

Canadian Standards Association certified (L404A,B,C,D,F; L604A,L only): file no. LR1620; guide no.400-E-0.

REPLACEMENT PARTS:

129178 Thermoplastic Cover.

14026 Steam Trap (siphon loop)—1/4 in. black iron pipe.

Necessary for boiler installations.

ACCESSORIES:

33312B Knurled Adjustment Knob—with setscrew; fits on main scale pressure adjusting screw.

4074BWJ Limit Stop Assembly—to limit set point ranges; includes 129564 Range Stop, 107194 Range Stop Screw, and 23466 Wrench.

TABLE 2—CONVERSION TABLE (psi to kPa).

Operating Range			Subtractive Differential		
Scale-Plate (psi)	Equivalent		Scale-Plate (psi)	Equivalent	
	(kg/cm <sup>2</sup> )	(kPa)		(kg/cm <sup>2</sup> )	(kPa)
0 to 15	0 to 10	0 to 103	—	—	—
2 to 15	.14 to 1.0	14 to 103	1 to 6 2 to 6	.07 to .4 .14 to .4	7 to 41 14 to 41
5 to 50	.3 to 3.5	34 to 345	4 to 12 5 to 14	.3 to .8 .4 to 1.0	28 to 83 41 to 97
5 to 150	.3 to 10.3	34 to 1034	—	—	—
10 to 150	.7 to 10.3	69 to 1034	8 to 16 10 to 22	.6 to 1.1 .7 to 1.5	55 to 110 69 to 152
20 to 300	1.4 to 20.7	138 to 2068	15 to 40 20 to 50	1.0 to 2.8 1.4 to 3.5	103 to 276 138 to 345

Fig. 1—Mounting dimensions of the L404A,B,C,D,F and L604A,L,M Pressuretrol® Controllers, in in. (mm).

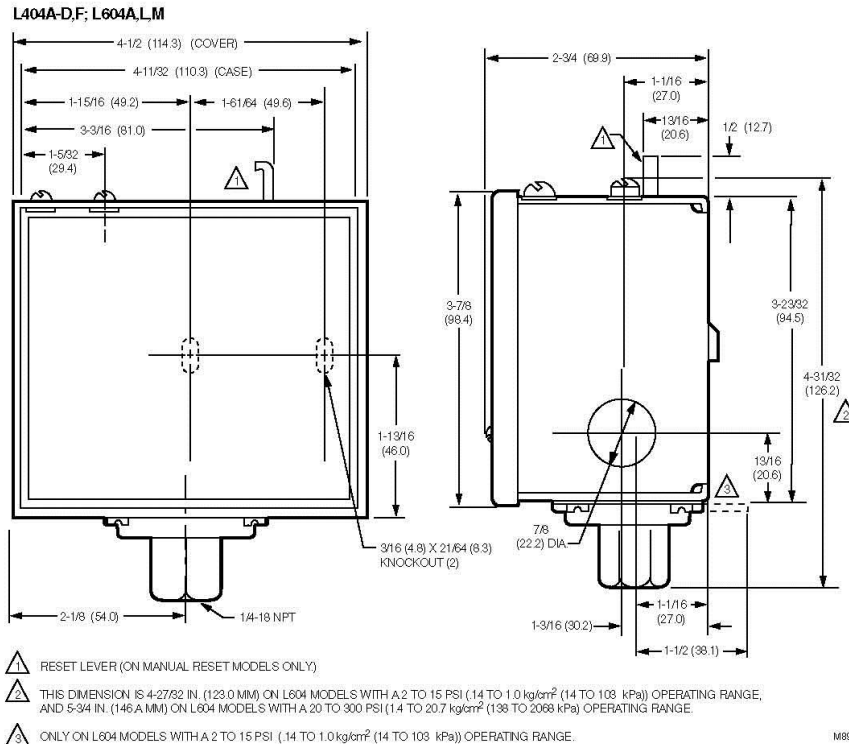

## Installation

### WHEN INSTALLING THIS PRODUCT...

1. Read these instructions carefully. Failure to follow them could damage the product or cause a hazardous condition.
2. Check the ratings given in the instructions and on the product to make sure the product is suitable for your application.
3. Installer must be a trained, experienced, flame safeguard control technician.
4. After installation is complete, check out product operation as provided in these instructions.

### CAUTION

1. Disconnect power supply before beginning installation to prevent possible equipment damage or electrical shock.
2. When using the controller with a compressor, install a dampening device (such as a needle valve, header, or surge tank) to dampen pulsations that can damage the controller or reduce its life.

### IMPORTANT:

1. Locate the controller where the ambient temperature will not exceed 150°F (66°C).
2. Use pipe compound sparingly to avoid clogging the hole in the pipe or diaphragm fitting.
3. Do not tighten the controller by hand by holding the case.
4. Accurately level the controller for proper operation.

### LOCATION AND MOUNTING

NOTE: For most accurate operation; add supplemental heat to installations where the temperature falls below minus 20°F (minus 29°C). Never locate the controller where the temperature falls below minus 35°F (minus 37°C), because mercury in the switch freezes at this temperature.

When used with steam boilers, always mount the controller *above the water line* in the boiler. A steam trap (siphon loop) must always be connected between the controller and the boiler (Fig. 2) to prevent boiler scale and corrosive vapors from attacking the diaphragm. The loop on the steam trap must always be perpendicular to the face of the controller. If the loop is parallel to the controller, expansion or contraction of the loop tips the controller and causes the switch to operate inaccurately.

The controller can be mounted (1) alongside the pressure gauge, (2) in a fitting on the boiler provided by the manufacturer, (3) at a remote location in case of excessive vibration, or (4) in a special mounting on a low water cutoff.

Fig. 2—Right and wrong mounting of a steam trap (siphon loop), with approximate dimensions in in. (mm).

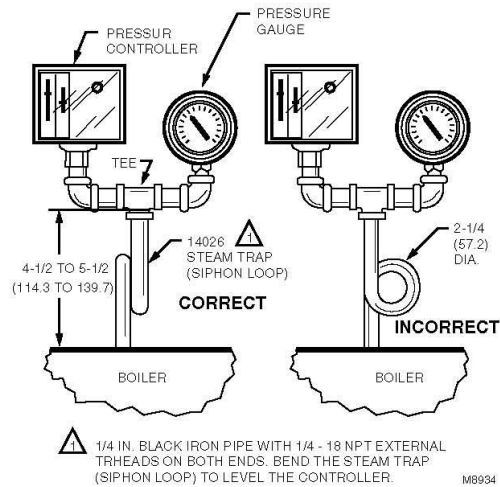

Make all pipe connections in accordance with approved standards. Use only a small amount of pipe compound to seal the connection joints. Excess pipe compound can clog the small hole in the fitting and prevent the controller from operating properly.

To avoid leaks and damage to the case, use a parallel jaw wrench on the controller's hexagonal fitting. *Do not tighten the controller by hand by holding the case.*

### Leveling

A controller with a mercury switch must be accurately leveled for proper operation. It is level when the leveling indicator (Fig. 11) hangs freely with its pointer directly over the index mark inside the back of the case. Level the controller by carefully bending the steam trap (siphon loop).

### Mounting Alongside a Pressure Gauge

To mount the controller *alongside a pressure gauge* (Fig. 2), remove the gauge. In its place, install a steam trap (siphon loop) with a tee on top. Using elbows and pipe nipples, mount the controller and pressure gauge on the ends of the tee. Level the controller after installation.

**Mounting on a Boiler**

If it is not convenient to mount the controller alongside the pressure gauge, install a steam trap (siphon loop) *in the fitting provided* by the boiler manufacturer. If there is no fitting, mount the steam trap at a location recommended by the boiler manufacturer. Screw the controller directly to the steam trap, and level the controller.

**Mounting at a Remote Location**

If there is *excessive vibration* at the boiler that can adversely affect the operation of the controller, mount the controller at a remote location. All piping from the boiler must be suitable and solidly mounted. The piping must be properly pitched to drain all condensation back to the boiler. A steam trap (siphon loop) must be mounted between the remote piping and the controller. Level the controller after installation.

**Supervision of Atomizing Medium Pressure (Air or Steam)—L404B**

When air or steam is used as an atomizing medium in an oil burner system, authorities having jurisdiction (approval bodies and codes) often require a low limit to prevent opening the main oil valve until sufficient atomizing pressure is present, and to shut down the system when the atomizing pressure falls too low.

The L404B is recommended for this application. It makes a circuit when the pressure rises to the set point, and breaks when the pressure falls to the set point minus the differential (Fig. 10).

**WIRING**

1. Disconnect the power supply before beginning wiring to prevent electrical shock or equipment damage.
2. Assume all wiring complies with applicable electrical codes, ordinances, and regulations. Use NEC Class 1 (line voltage) wiring.
3. For normal installations, use moisture-resistant No. 14 wire suitable for at least 167°F (75°C) when you are using the controller with a flame safeguard primary control, or at least 194°F (90°C) when using it with a programming control.
4. For high temperature installations, use moisture-resistant No. 14 wire, selected for a temperature rating above the maximum operating temperature.
5. All models have a terminal block inside the cover (Fig. 3 and 4) and a 7/8 in. (22.2 mm) hole in one side for 1/2 in. conduit, cable, or wires. Remove the front cover by loosening the screw at the bottom of the main scale.
6. Refer to Fig. 5 through 9 for typical hookups. Follow the burner or boiler manufacturer's wiring diagram if provided.
7. Make sure the loads do not exceed the Switch Contact Ratings in the Specifications section.
8. Replace the front cover when wiring is completed.

**Fig. 3—L404 terminal blocks and internal schematics.**

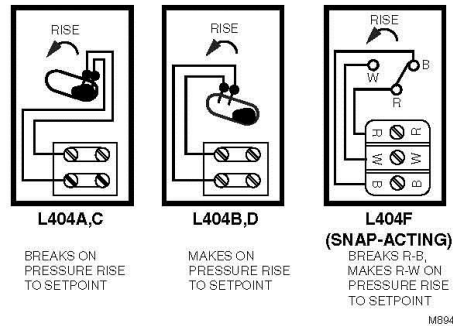

**Fig. 4—L404 terminal block and internal schematic.**

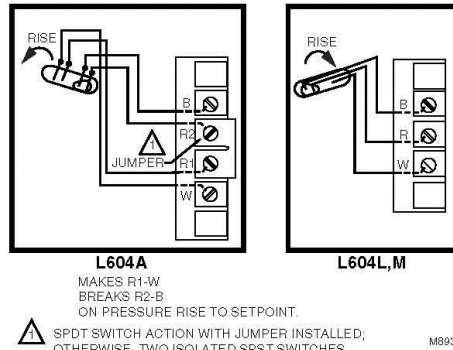

**Fig. 5—L404 used as a limit or as an operating controller.**

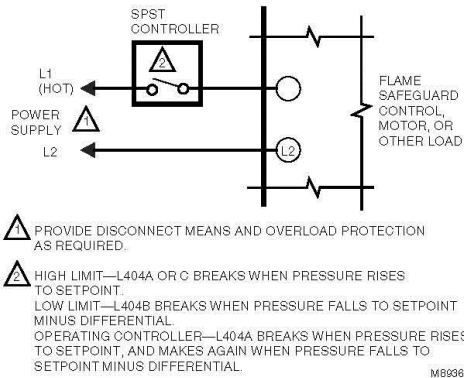

Fig. 6—L404 with a low voltage relay.

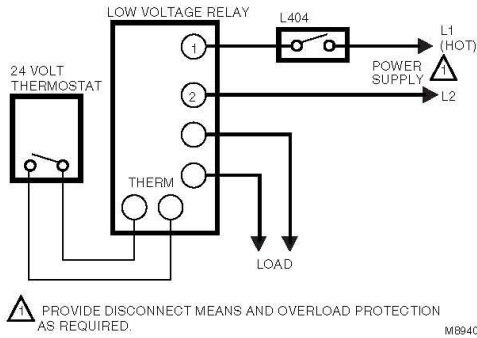

Fig. 7—L404F, L604A (jumper installed) used as a high limit, with an alarm circuit.

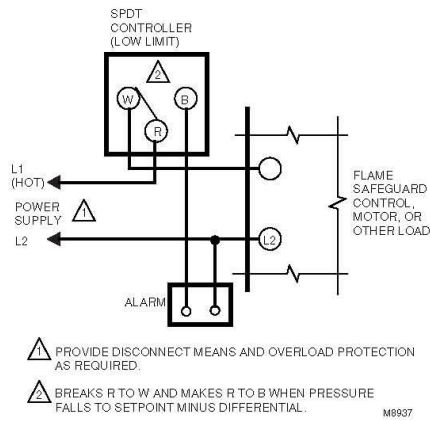

Fig. 8—L404F, L604A (with jumper installed) or L604M, used as a low limit, with an alarm circuit.

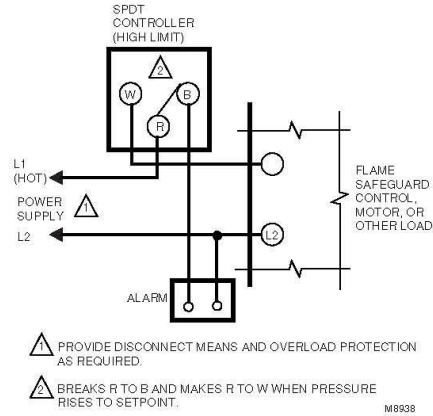
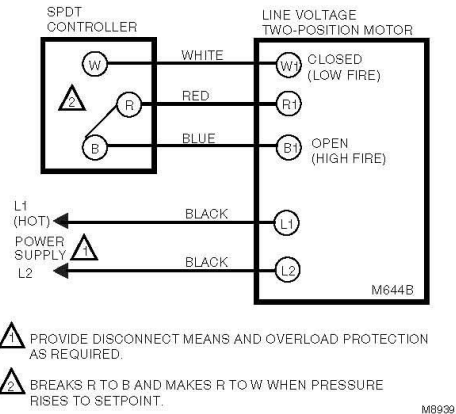

Fig. 9—L404F, or L604 with jumper installed, controlling an M644B motor.



## Setting and Checkout

### SETTING

In all models, the differential is subtractive from the main scale set point. The upper operating point is determined by the main scale set point, while the lower operating point is determined by the main scale setting less the differential setting. The L404F and L604A (with jumper installed), L,M have spdt switching action. Operating points are shown in Fig. 10.

Fig. 10—L404 and L604 operating points.

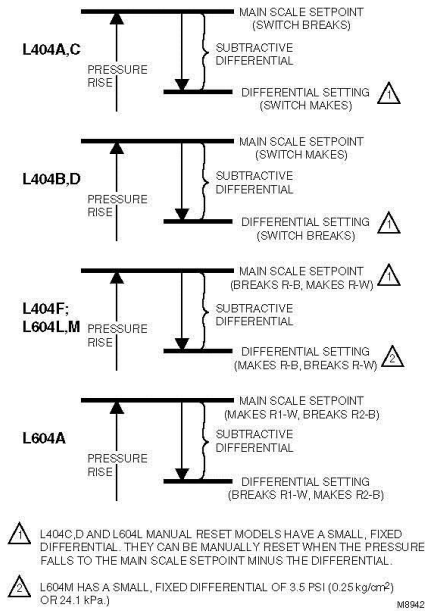

Adjust the main scale set point for the desired operating pressure by turning the main scale adjusting screw (Fig. 11) on the top of the case until the main scale setting indicator is at the desired value. On an L404A,B,F with a 5 to 150 psi (.3 to 10.3 kg/cm<sup>2</sup> [34 to 1034 kPa]) operating range, or an L604A, adjust the differential setting by turning the differential adjusting screw (Fig. 11) until the differential setting indicator is at the desired value. L404C,D and L604L are manual reset models: see the next paragraph. The L604M has a fixed differential. The scaleplates are marked psi and kg/cm<sup>2</sup>.

### Trip-Free Manual Reset Feature (L404C,D and L604L only)

The L404C breaks, the L404D makes, and the L604L makes R-W and breaks R-B when the pressure rises to the

main scale setpoint. They will not automatically return to their former positions. To reset one of these controllers, wait until the pressure falls to the set point minus the differential (Fig. 10). Then depress the manual reset lever (Fig. 11) and release it. The controller will not be reset until you release the manual reset lever. This prevents the controller from becoming an automatic-reset device if the reset lever is stuck, held in, or tied down.

Fig. 11—Setting a Pressuretrol® Controller.

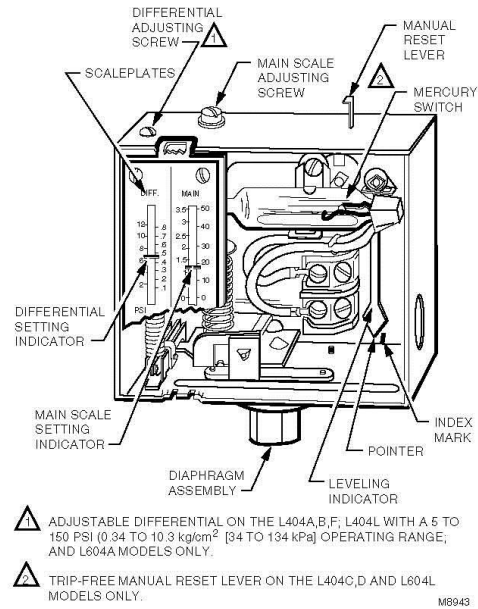

### CHECKOUT

After the controller has is installed, wired, and set, test it with the system in operation. First allow the system to stabilize. Then observe the operation of the controller while raising and lowering its setpoint. Pressure should increase when the setpoint is raised and decrease when the set point is lowered.

Also check the make and break points of the controller. If they do not agree with a separate, accurately calibrated pressure gauge, a slight adjustment of the scaleplate(s) may be necessary.

Use accurate pressure testing equipment when checking out the controller. Do not rely on inexpensive gauges. The controllers are carefully calibrated at the factory.

### Boiler Installation

If the controller is being used on a boiler installation, test it as follows:

1. Note the boiler pressure by checking the boiler pressure gauge. (To perform this test properly, the boiler should have a pressure reading near the middle of the controller's main scale range.)

2. Turn the main scale adjusting screw (Fig. 11) until the main scale setting indicator on the controller corresponds to the boiler pressure gauge reading.

3. The L404A or C should break the control circuit(s) automatically when the boiler pressure gauge reading equals or slightly exceeds the controller setting.

The L404B or D should make the circuit under the same circumstances.

The L404F; L604L,M should make the R-W circuit and break the R-B circuit under the same circumstances.

The L604A should make the R1-W circuit and break the R2-B circuit under the same circumstances.

4. If the controller is operating properly, turn the main scale adjusting screw (Fig. 11) until the main scale setting indicator is at the desired set point.

### If a Controller Seems to Operate Improperly

If the controller is suspected of operating improperly, it may be further checked as follows (Fig. 12):

1. Disconnect all power to the controller, loosen the cover screw, and remove the cover.

2. Disconnect the wires from the controller.

3. Connect an ohmmeter between the switch terminals.

4. Lower the set point of the controller (simulating a pressure increase) through a range greater than the differential. The switch should either make or break, depending on the model of the controller. (An L404A or C should break, an L404B or D should make, an L404F; L604L,M should break R-B and make R-W, and an L604A should break R2-B and make R1-W.) If it makes, the ohmmeter reads zero; if it breaks, the ohmmeter reads infinity.

5. Raise the set point of the controller (simulating a pressure decrease) through a range greater than the differential. The switch should break or make, just the opposite of its action in step 4 (except for the L404C,D and L604L manual reset models).

NOTE: An approximation of the differential can be made by observing the change in set point required for a resistance change from zero to infinity.

6. If the controller operates improperly, replace it.

7. When the controller is operating properly, reconnect the wires to the terminal block, replace the cover and tighten the cover screw, and reconnect the power.

## ! CAUTION

Do not put the system into service until you have satisfactorily completed all applicable tests described in this Checkout section, in the Checkout section of the applicable instructions for the flame safeguard control, and any others required by the burner and boiler manufacturers.

Fig. 12—Checking controller operation using an ohmmeter.

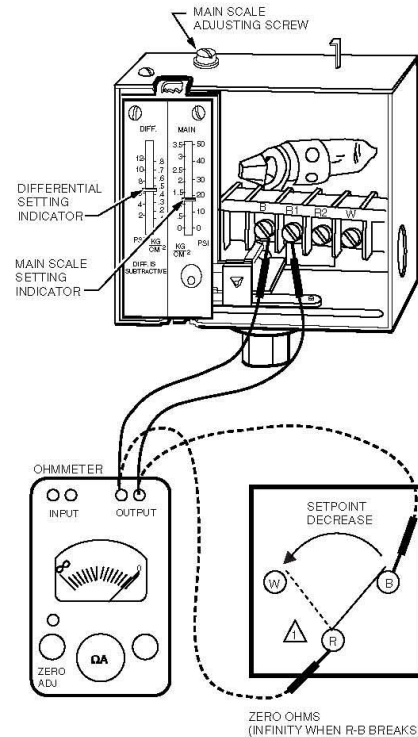

ZERO OHMS  
(INFINITY WHEN R-B BREAKS)

! AN L604, WITH JUMPER INSTALLED BETWEEN R1 AND R2, IS SHOWN; AN L404F OPERATES SIMILARLY (SPDT SWITCHING). AN L404A, B, C OR D HAS ONLY TWO TERMINALS (SPST SWITCHING); AN L404A OR C BREAKS AND L404B OR D MAKES WHEN THE SETPOINT IS DECREASED FAR ENOUGH.

M8944

# P7810C PressureTrol® Controller

**PRODUCT DATA**



## FEATURES

- Use only with steam, air or noncombustible gases that do not corrode the pressure sensing element.
- Models available in 15, 150 and 300 psi (103, 1034 and 2069 kPa) maximum setpoints.
- Light Emitting Diode (LED) indicators show power, call for heat function and lockout status.
- Clear cover allows setpoint and differential to be read, but not adjusted without opening the cover.
- Manual reset possible without opening the cover.
- Electronic maximum fixed stop limit.

## APPLICATION

The P7810C PressureTrol® Controller is a line voltage pressure controller for pressure systems up to 300 psi (2069 kPa). The P7810C provides On/Off Control, High Limit and 4 to 20 mA modulation.

## Contents

Application .....	1
Features .....	1
Specifications .....	2
Ordering Information .....	2
Installation .....	3
Checkout .....	10
Troubleshooting .....	11
Service Information .....	11



65-0285-1



## SPECIFICATIONS

**Model:**  
P7810C PressureTrol® Controller with On/Off control, modulate and safety high limit.

**Electrical Ratings:**  
Power Input: 120 Vac (+10% /-15%), 50/60 Hz (±10%).  
Power Consumption: See Table 1.  
Output Impedance: 300 ohm maximum.

**Table 1. Power Consumption.**

Rating	120 Vac	
	50 Hz	60 Hz
Watts	21.8	2.8
VA	7.0	7.0

**Switch Contact Ratings:** See Table 2.

**Table 2. Switch Contact Ratings.**

Relay	Load Type	120 Vac
Control	Amps Full Load (FLA)	9.8A
	Amps Locked Rotor (ALR)	58.8A
	Non-Inductive	10.0A
Alarm	Pilot Duty	1.0A

**Sensor Material:** 304 stainless steel.

**Pressure Connector:** 1/2 in. NPT.

**Case Material:** Plastic.

**Electrical Terminations:** Screw terminals.

**Accuracy:** ±4.0 percent full scale output operating range, over operating temperature.

**Environmental Ratings:**  
Operating Temperature Range: 32°F to 140°F (0°C to 60°C).  
Storage Temperature Range: -20°F to +150°F (-29°C to +66°C).  
Humidity: 5% to 95% relative humidity, noncondensing.  
Vibration: 0.5G continuous maximum vibration.

**Dimensions:** See Fig. 1.

**Mounting Position:** Upright, see Fig. 2.

**Device Weight:** 2.0 lb, 8 oz (1.15 kg).

**Approvals:**  
Underwriters Laboratories Inc.: Listed.  
Canadian Standards Association Listed: Pending.  
Factory Mutual Approved: Approved, J.1.2D3A50F.  
CSD-1 AFB (Control Safety Devices, Automatic Fired Boilers): Acceptable.  
FCC Class B, computing devices, part 15.

**Accessories:**  
205860 Minimum Position Potentiometer for Series 70 Motors.  
209731A Siphon Loop with 1/2 in. NPT threads.  
4074EWD Mounting Bracket with six screws.  
4074EDC or EED Bag Assembly to interface 4 to 20 mA with Series 90 Firing Rate Motor.

**Replacement Parts:**  
4074EWC Door Assembly with captive screw and adjusting wrench (replacement part for P7810C).  
4074EVP Door Wrench.

**Pressure Ratings:** See Table 3.

**Table 3. Pressure Ratings (psig).**

Pressure Range	Maximum Setpoint	Differential	Overpressure	Burst Pressure
0 to 15	15	2 to 10	22.5	60
0 to 150	150	5 to 20	225	600
0 to 300	300	15 to 50	450	1200

## ORDERING INFORMATION

When purchasing replacement and modernization products from your TRADELINE® wholesaler or distributor, refer to the TRADELINE® Catalog or price sheets for complete ordering number.

If you have additional questions, need further information, or would like to comment on our products or services, please write or phone:

1. Your local Honeywell Automation and Control Products Sales Office (check white pages of your phone directory).
2. Honeywell Customer Care  
1885 Douglas Drive North  
Minneapolis, Minnesota 55422-4386

In Canada—Honeywell Limited/Honeywell Limitée, 35 Dynamic Drive, Scarborough, Ontario M1V 4Z9.  
International Sales and Service Offices in all principal cities of the world. Manufacturing in Australia, Canada, Finland, France, Germany, Japan, Mexico, Netherlands, Spain, Taiwan, United Kingdom, U.S.A.

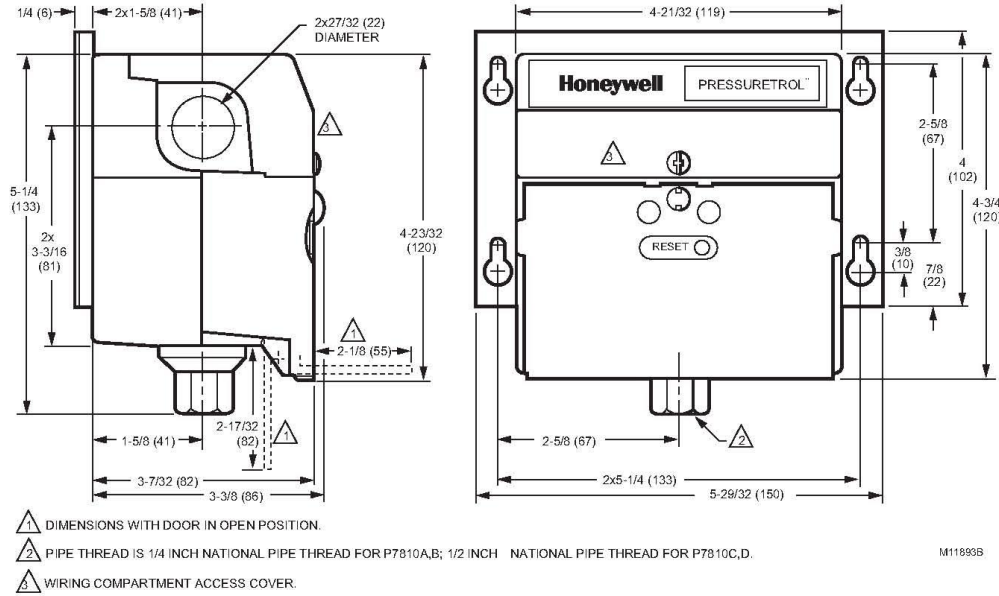

Fig. 1. Approximate dimensions of P7810C PressureTrol® Controller in in. (mm).

## INSTALLATION

### When Installing This Product...

1. Read the instructions carefully. Failure to follow them could damage the product or cause a hazardous condition.
2. Check ratings (pressure and voltage, for example) and description given in the specifications to make sure the product is suitable for your application.
3. Installer must be a trained, experienced technician.
4. After installation is complete, check out product operation as provided in these instructions.

### **⚠** WARNING

**Electrical Shock Hazard and Explosion Hazard.  
Can cause severe injury, death or property damage.**

1. Disconnect power supply before installation. More than one disconnect may be involved.
2. Allow pressure to decrease to atmosphere from the pressure vessel before removing old control.
3. Follow all installation and checkout procedures for safe installation.

### IMPORTANT

*Do not remove the overpressure inlet seal until ready to connect piping, to prevent contamination of inlet.*

### Location

Install the P7810C PressureTrol® Controller above the boiler water line when used with steam boilers. Connect the siphon loop (part number 209731A or equivalent) between the P7810C Controller and the boiler to prevent scale and corrosive vapors from attacking the controller sensor element. Mount the P7810C Controller next to the pressure gauge in the manufacturer-provided fitting on the boiler. See Fig. 2 and 3. Mount at a remote location to avoid excessive vibration, or mount in a special mounting on a low water cutoff.

### IMPORTANT

1. Locate the P7810C PressureTrol® Controller where ambient temperature does not exceed 140°F (60°C).
2. Use pipe compound sparingly to avoid clogging the hole in the pipe or the sensor element fitting.
3. Do not hand tighten the controller connection by holding the case. Use a wrench on the flats of the sensor fitting to avoid leaks and damage to the case.
4. Level the controller for appearance.
5. Install the P7810C where the relative humidity never reaches the saturation point. The P7810C is designed to operate in a maximum 85 percent relative humidity, continuous, noncondensing moisture environment. Condensing moisture can cause a shutdown.
6. Do not install the P7810C where it could be subjected to vibration in excess of 0.5G continuous maximum vibration.
7. The P7810C is not designed to be weather-tight. If installed outdoors, protect the P7810C with an approved weather-tight enclosure.

P7810C PRESSURETROL® CONTROLLER

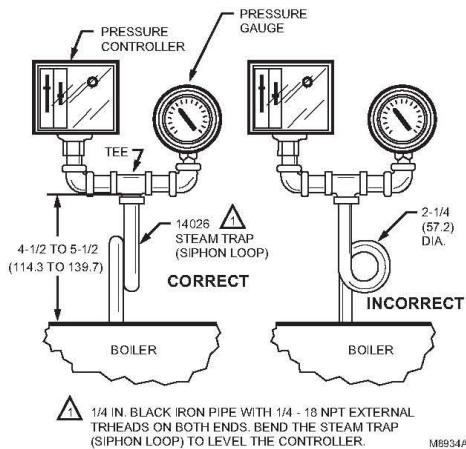

Fig. 2. Right and wrong mounting of steam trap (siphon loop) for the P7810C, with approximate dimensions in in. (mm).

**Mounting**

Make all pipe connections in accordance with applicable local standards. Use parallel jaw wrench to tighten P7810C Controller hexagonal fitting to avoid leaks and damage to the case.

**Mounting P7810C Controller next to pressure gauge**

To mount the P7810C PressureTrol® Controller next to the pressure gauge:

1. Remove the pressure gauge.
2. Replace the gauge with a siphon loop with tee connector on top.

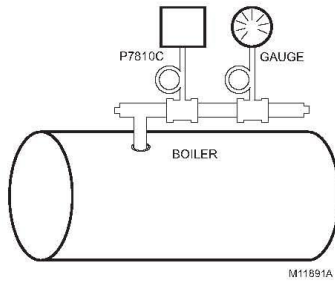

Fig. 3. Connecting P7810C PressureTrol® Controller to steam boiler.

3. Mount the P7810C Controller and pressure gauge on the end of the tee.

4. If not convenient to mount the P7810C Controller next to the pressure gauge, install a siphon loop in the manufacturer-provided fitting.
5. If there is no fitting, mount the siphon loop at the boiler manufacturer recommended location.
6. Attach the P7810C Controller directly to the siphon loop.
7. Level the P7810C Controller after the installation.

NOTE: The P7810C model requires 1/2 in. (13 mm) mounting, either directly or on a siphon loop.

Remote Location Mounting

Excessive vibration at the boiler can damage the P7810C Controller electronics.

1. Mount the P7810C Controller at a remote location to eliminate vibration problems.
2. Make sure that all piping from the boiler is suitable to the application and is solidly mounted.
3. Pitch the piping properly to drain the condensate back to the boiler.
4. Mount the siphon loop between the remote piping and the P7810C Controller.
5. Level the P7810C Controller after the installation.

**WIRING**

**⚠ WARNING**

**Electrical Shock Hazard.**  
Can cause severe injury, death or property damage. Disconnect the power supply before wiring. More than one disconnect may be involved.

All wiring must comply with applicable electrical codes, ordinances and regulations. Use NEC Class 1 line voltage wiring.

For nominal installation, use moisture-resistant No. 14 wire (maximum size allowed) suitable for at least 167°F (75°C) or 194°F (90°C) for Flame Safeguard Primary Controls.

Use shielded wire for 4 to 20 mA modulating output and terminate the shield to earth ground. Do not run these wires in the same conduit as high voltage ignition wires.

All P7810C PressureTrol® Controllers have terminal screws and 27/32 in. (22 mm) holes in both sides for conduit, cables and wiring. Remove the top cover by loosening the screw at the top of the P7810C Controller case.

Follow the burner or boiler manufacturer wiring diagram, if provided. Make sure the loads do not exceed the contact ratings in the Specifications section. See Fig. 4 for terminal locations and Fig. 5 through 9 for typical wiring hookups.

Table 4 provides conversion wiring information for upgrading older P7810 devices to newer series.

Replace the front cover after completing the wiring.

**IMPORTANT**

Line voltage wiring terminals have changed between Series 2 and Series 3 models.

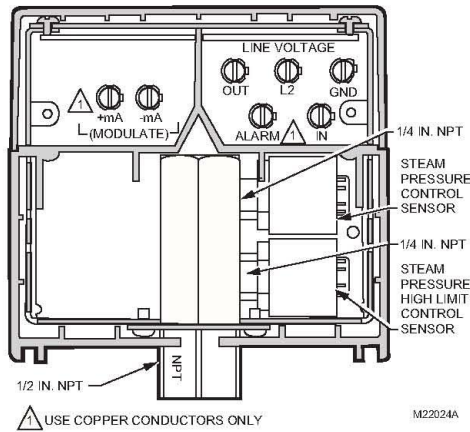

Fig. 4. P7810C (Series 3 or greater) PressureTrol® Controller.

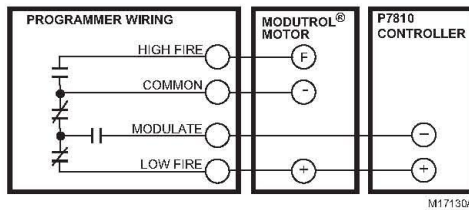

Fig. 5. Firing rate wiring diagram using 4 to 20 mA controller and series 70 Modutrol® Motor.

Table 4. Conversion Wiring Information for Upgrading Older P7810 Devices to Newer Series.

Signal/Input	Series 1 Terminals	Series 2 Terminals	Series 3 or Greater Terminals
4 to 20 mA signal output (-)	-	-	-
4 to 20 mA signal output (+)	+	+	+
Limit string output to programmer	N.O.	OUTPUT	OUT
L1 (Hot)	COM	L1 <sup>a</sup>	IN <sup>a</sup>
120 Vac Power Supply (L2)	L2	L2	L2
120 Vac Power Supply (L1)	L1	b	b
External Alarm Device	—	ALARM	ALARM

<sup>a</sup> If any additional/external limits are used, make sure they are inserted between the P7810C PressureTrol® Controller and the Programmer in the Limit string.

<sup>b</sup> When converting to a newer series from Series 1, L1 (120 Vac Power Supply) lead wire is not used, remove or wire-nut and tuck away.

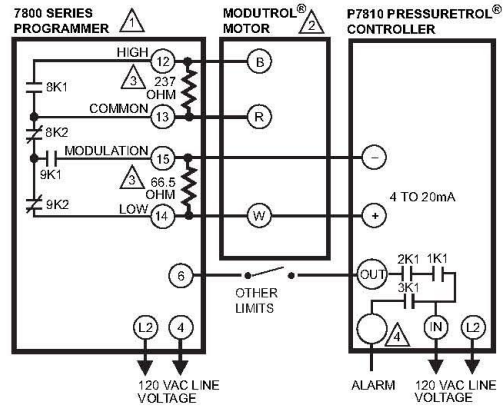

— FIELD WIRING    - - - - - DEVICE WIRING

- ⚠ 7800 SERIES SHOWN. REFER TO SPECIFICATIONS PACKED WITH THE PROGRAMMER FOR WIRING OF OTHER PRIMARY SAFETY CONTROLLERS.
- ⚠ MODUTROL® MOTOR MUST BE MODUTROL III OR MODUTROL IV, SERIES 90, ELECTRONIC BALANCE RELAY TO OPERATE AS SHOWN.
- ⚠ PART OF 4074EDC OR 4074EED BAG ASSEMBLY ORDERED SEPARATELY.
- ⚠ LINE VOLTAGE TO PROGRAMMER AND CONTROLLER SHOULD BE IN PHASE.
- ⚠ SEE CONVERSION WIRING TABLE FOR CONVERTING OLDER SERIES DEVICES.

M13698

Fig. 6. Wiring diagram for typical P7810 installation, Series 3 and greater, using Series 90 Modutrol® Motor.

P7810C PRESSURETROL® CONTROLLER

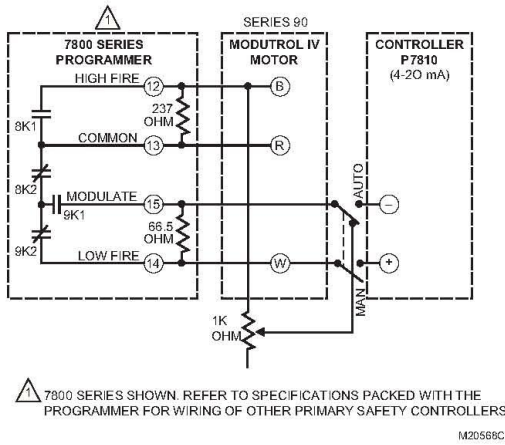

Fig. 7. Firing rate wiring diagram using P7810C PressureTrol® Controller and Series 90 Modutrol® Motor with manual position potentiometer and auto-manual switch.

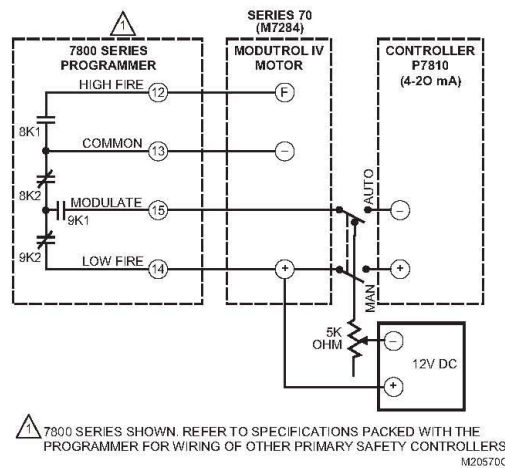

Fig. 9. Series 70 Motor with auto/manual switch and 12 Vdc source.

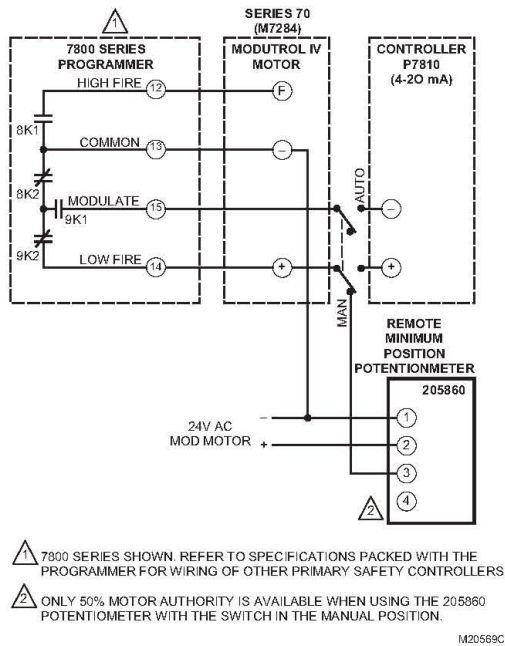

Fig. 8. Series 70 Motor with auto/manual switch, using 205860 Minimum Position Potentiometer.

## OPERATION

The P7810 uses integral electronic pressure sensors to sense pressure at the inlet through an internal manifold. The control sensor connects to the internal manifold with 1/4 inch NPT threads and provides the pressure signal to control a relay for the on/off control function. The same sensor provides the information for the 4 to 20 mA firing rate modulation output.

A separate integral electronic pressure sensor is required to provide the high limit function. This sensor also connects to the internal manifold with 1/4 inch NPT threads. P7810C devices contain two internal sensors and require a 1/2 inch NPT mounting to the steam pressure header. Devices with high limits lock out at setpoint and require manual reset when pressure returns below the setpoint. Devices will not reset with power interruption.

The P7810C has on/off function, 4 to 20 mA modulation control output, and safety high limit function in one control. A 1/2 inch NPT mounting is required to the steam pressure header.

### Pressure On/Off Control Function

When pressure increases to the control setpoint, the control relay contacts open. The relay contacts close when the pressure decreases to a level at or below (differential) the control range differential setting. This cycle continues until power is removed, opening the relay. See Fig. 10.

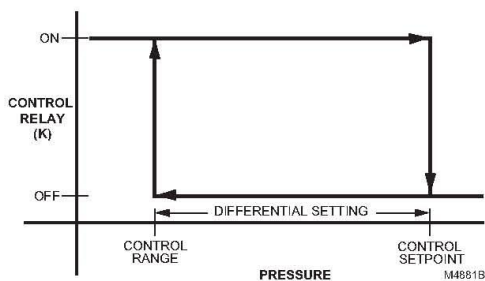

Fig. 10. P7810 on/off control function versus pressure.

### Modulate Control Function

When the pressure decreases to or below the modulation setpoint, the current is 20 mA. The current remains constant at all pressures below the modulation setpoint.

The modulation range is an additive value to the modulation setpoint value.

When the pressure increases above the modulation setpoint, the current decreases linearly until the modulation range point is reached. The output current is 4 mA at and above this pressure. See Fig. 11.

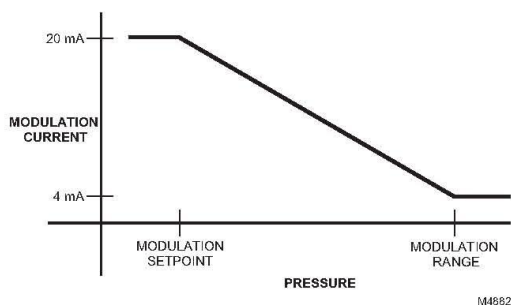

Fig. 11. P7810C modulation current versus pressure.

### Limit Function

The Limit potentiometer has two functions:

- To set the **Maximum Fixed Stop Limit**. This is the maximum pressure setting that the P7810C control can be adjusted to and still perform its intended function (i.e., safety shutdown).

### CAUTION

**Equipment Damage Hazard.**  
Exceeding pressure vessel limits can damage equipment.  
The **Maximum Fixed Stop Limit** pressure setting must not exceed the maximum working pressure rating of the pressure vessel. Adjust the **Maximum Fixed Stop Limit** setting to the maximum working pressure rating that is stamped on the pressure vessel by the manufacturer.

- To set the **High Limit Setpoint**. This is the desired pressure value to which the P7810C control is adjusted at at which it performs its intended function (i.e., safety shutdown).

The High Limit Setpoint can be set lower than the internal stored Maximum Fixed Stop Limit Value and will provide system lockout at the knob setting. For example, the internal stored Maximum Fixed Stop Limit Value is 12 psi and the knob is set at 10 psi. System lockout is at 10 psi. The LED pattern will be green on and yellow blinking slowly.

The High Limit Setpoint can be set above the internal stored Maximum Fixed Stop Limit Value but it will have no functional effect. For example, the internal stored Maximum Fixed Stop Limit Value is 12 psi and knob is set at 14 psi. Lockout will occur at 12 psi. The LED pattern will be green on and yellow blinking fast.

When pressure increases to the high limit setpoint, the relay contacts (1K1, 2K1) open and the P7810C indicates a safety lockout by alternately flashing the yellow and green LED. The P7810C remains in this condition until the manual reset button (see Fig. 1) is pressed. The Alarm relay contacts (3K1) will close, providing a 120 Vac output on the Alarm terminal.

### Reset Switch Functions

The Reset Switch has the functions listed in Table 5.

### P7810C PressureTrol® Controller Setup

For the P7810C PressureTrol® Controllers with more than one function (control, modulate and high limit), adjust setpoints and differentials separately for each function.

### CAUTION

**Equipment Damage Hazard.**  
**IMproper setting of control setpoint and control range knob errors can damage the P7810C.**  
Adjust setpoints and differentials using the knobs on the front of the P7810C PressureTrol® Controller.

Set the knobs to the desired points by aligning the center of the knob arrow with the desired mark on the scale plate. See Fig. 12.

Table 5. Reset Switch Function, P7810C.

Reset Switch Action	P7810C Modes of Operation				
	Lockout	Unconfigured	(Run) Normal Operation	Power-up (Configuration Time Expired)	Power-up (Configuration Time Not Expired)
Press and Continuously Hold.	Blink existing fault code until the reset switch is released.	Both LED turn on after three seconds, indicating the Maximum Fixed Stop Limit Value has been stored. Wait for up to 30 seconds for a release. Enter lockout after 30 seconds.	The green LED turns off and the yellow LED turns on, waiting until the reset switch is released.	Both LED turn on. Wait for up to 30 seconds for a release. Lockout after 30 seconds. If released within 30 seconds, enter normal operation.	Enter unconfigured mode of operation.
Press and release.	Clear the fault code and reset the P7810C.	Press and release of the Reset Switch within three seconds is ignored. If the Reset Switch is pressed for more than three seconds, both LED turn on and the Maximum Fixed Stop Limit Value is stored into non-volatile (NV) memory. Upon release, the device will recycle and enter normal operation.	Resets the control.	Enter normal operation.	Enter unconfigured mode of operation.

Setting Maximum Fixed Stop Limit Value

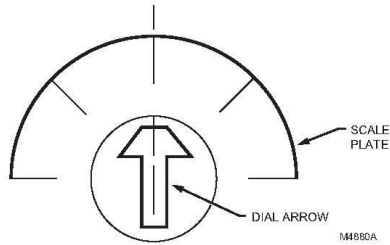

Fig. 12. Setting control setpoint and control range knobs.

**IMPORTANT**

P7810C devices must set Maximum Fixed Stop Limit Value function first.

**CAUTION**

Equipment Damage Hazard. Exceeding pressure vessel limits can damage equipment.

The Maximum Fixed Stop Limit pressure setting **must not** exceed the maximum working pressure rating of the pressure vessel. Adjust the Maximum Fixed Stop Limit setting to maximum working pressure rating that is stamped on the pressure vessel by the manufacturer.

**IMPORTANT**

The Maximum Fixed Stop Limit Value must be programmed first for the P7810C to operate.

1. Initial Startup—Maximum Fixed Stop Limit Value is unprogrammed.
  - a. Green LED (Control LED)—Blinking rapidly (1/2 second on, 1/2 second off).
  - b. Yellow LED (Power LED)—On steady and bright.
2. Setting the Maximum Fixed Stop Limit Value.
  - a. Monitor the 4 to 20 mA output. Long filtering delays cause a lag between the 4 to 20 mA output and the limit setting, i.e., 20 to 25 seconds for a full-scale change.
  - b. Turn the Limit Setpoint knob to the desired setting and confirm by comparing the current noted to the corresponding reading in Table 6. Ensure that the mA output is stable before using the value.
  - c. Press and hold the Reset Switch.

- d. Release the Reset Switch when both LED turn on.
- e. The Maximum Fixed Stop Limit Value is set and the device will recycle and attempt to enter the Run mode.
- f. After an accumulated run time (Call for Heat) of one hour (Series 1 and 2) or eight hours (Series 3 or greater), the Maximum Fixed Stop Limit Value setting will be permanently stored in the P7810C memory. Changing the Maximum Fixed Stop Limit Value setting after this time will then be ineffective.

**Table 6. Setting Maximum Fixed Stop Limit Value—Current Readings.**

15 psi	150 psi	300 psi	4 to 20 mA Output
0	0	0	4.00
1	10	20	5.07
2	20	40	6.13
3	30	60	7.20
4	40	80	8.27
5	50	100	9.33
6	60	120	10.40
7	70	140	11.47
8	80	160	12.53
9	90	180	13.60
10	100	200	14.67
11	110	220	15.73
12	120	240	16.80
13	130	260	17.87
14	140	280	18.93
15	150	300	20.00

**Changing the Maximum Fixed Stop Limit Value Setting (if Run Time is less than one hour [For Series 1 and 2] or less than eight hours [For Series 3 or greater])**

1. Remove power from the P7810C.
2. Press and hold the Reset Switch, then apply power to the P7810C.
3. When the green LED blinks rapidly, release the Reset Switch.
4. Follow the steps in Setting the Maximum Fixed Stop Limit Value, above.

NOTE: If both LED turn on, the configuration timer (one hour) has expired. Release the Reset Switch and continue normal operation. Changing the Maximum Fixed Stop Limit Value Setting is no longer allowed.

**Checking the Maximum Fixed Stop Limit Value (Stored in Memory)**

NOTE: The P7810C must be powered and in the Run mode.

1. Record the original location of the Limit setpoint knob. Make sure that the Limit setpoint knob is set (moved to) a lower value than the Maximum Fixed Stop Limit Value setpoint. The green LED will be reflective of the call for heat status and the yellow LED will blink slowly.

**IMPORTANT**

*Do not decrease the Limit Setpoint knob far enough to cause a lockout.*

2. Very slowly increase the Limit setpoint knob until the yellow LED begins to blink fast. The current position of the Limit setpoint now represents the Maximum Fixed Stop Limit Value setpoint stored in memory.
3. Return the Limit setpoint knob to the original location (step 1).

**Setting High Limit Setpoint**

After the Maximum Fixed Stop Limit Value has been stored into memory, adjust the Limit setpoint knob to the desired pressure value at which safety shutdown (lockout) will occur when the vessel pressure exceeds this setpoint value.

NOTE: The High Limit setpoint value can be less than or equal to the Maximum Fixed Stop Limit Value but cannot be set to a value higher than the Maximum Fixed Stop Limit Value.

**Pressure On/Off Control**

Adjust the setpoint and differential using the potentiometer knobs on the front of the controller. The differential is a subtractive value from the setpoint adjustment. The upper operating point is determined by the control setpoint, while the lower operating point is determined by the control range setting (control setpoint minus the differential setting).

Set the potentiometer knobs to the desired point by aligning the center of the arrow on the potentiometer knob with the desired mark on the scale plate. See Fig. 12.

Yellow LED ON constantly indicates power applied; green LED On indicates closed contact or call for heat.

**Modulate Control**

The P7810C adds 4 to 20 mA modulation output and uses two additional potentiometers. The pressure sensor output is fed to an error and gain amplifier to perform the modulation determined by the control potentiometer settings.

The potentiometer knobs mounted on the P7810C face adjust the current output for a given set of pressures.

The modulation range is an additive value to the modulation setpoint value.

**LED Display (Tables 7 and 8)**

The yellow LED is always lit with power applied to the P7810C PressureTrol® Controller. The microprocessor changes the brightness of the yellow LED to indicate normal operation, turns the green LED on and off to indicate call for heat status and flashes both LED to indicate a fault.

NOTE: The term "flashing" means on/off/on/off for the green LED and bright/dim/bright/dim for the yellow LED.



Press and hold the Reset Switch to access internal diagnostics. The green (right) LED will flash a series of long followed by a series of short flashes. Count the long and short flashes and check the fault code table (Table 8) for information.

For example: four long and three short flashes is code 43. If you miss the code the first time, keep holding the Reset Switch down and the code will repeat. Letting go of the Reset Switch clears the fault information and resets the P7810.

Table 7. P7810 Blink Codes.

Yellow	Green	Control State
Off	Off	Device off.
No LED blinking		Device on, Central Processing Unit (CPU) malfunction.
Slow Blink	Off	Run mode, output off, Limit potentiometer setpoint used.
Slow Blink	On	Run mode, output on, Limit potentiometer setpoint used.
Fast Blink	Off	Run mode, output off, Internal Maximum Fixed Stop Value setting used.
Fast Blink	On	Run mode, output on, Internal Maximum Fixed Stop Value setting used.
Alternating Fast Blinks		Lockout, output off, high limit exceeded, Alarm output engaged.
Simultaneous Fast Blinks		Lockout, output off, internal fault, Alarm output engaged.
On, Bright	Fast Blink	Output off, internal Maximum Fixed Stop Value setting not set.

Table 8. LED Fault Codes and Recommended Troubleshooting.

Fault Code	System Failure	Recommended Troubleshooting
11	High Limit Setpoint Exceeded.	When pressure in vessel returns to normal, P7810C can be reset.
12-32, 71-90, 92	Internal fault.	Reset P7810C; if same fault occurs again, replace P7810C.
51, 54, 61	Internal fault—internal relays welded.	Verify loads do not exceed rating of P7810C contacts, then replace P7810C.
52-69, 91	Relay fault.	Verify that no voltage potential exists on Output terminal. If code repeats after normal operation, look for back feed of voltage greater than 50V (ac or dc) any time during boiler sequence. Replacing P7810C will only result in same lockout on new control.

## CHECKOUT

### WARNING

**Electrical Shock Hazard and Explosion Hazard. Can cause severe injury, death or property damage.**

1. Line voltage is present at the P7810C and all controller circuits. Use extreme care during checkout.
2. This checkout procedure disables the Safety High Limit function.

#### IMPORTANT

1. Do not put the system into service until all applicable tests described in the Checkout section of the instructions for the primary safety control and any additional tests required by the burner or boiler manufacturer are satisfactorily completed.
2. Close all manual fuel shutoff valves when trouble occurs.

After installation and wiring, check out the P7810C PressureTrol® Controller with the system in operation.

#### Checkout

1. Allow the system to stabilize.
2. Observe the operation of the P7810C while raising and lowering the setpoint. Pressure increases when the setpoint is increased and decreases when the setpoint is decreased.

3. Check the make and break points of the P7810C. If they do not agree with a separate, accurately calibrated pressure gauge, make a slight adjustment according to the scale. Use accurate pressure testing equipment when checking out the P7810C. Do not rely on inexpensive gauges. The P7810C is carefully calibrated at the factory.

Test the P7810C PressureTrol® Controller as follows:

NOTE: Make sure the P7810C is operating properly by checking the LED indicators. If the P7810C LED indicate a lockout condition, press the manual Reset Switch.

NOTE: This procedure simulates pressure changes using knob setpoint adjustments. Make knob adjustments very slowly because of filtering delays within the P7810C (20 to 25 seconds for full scale changes). Inaccuracy can result if knob adjustments are not made very slowly. To observe actual P7810C control accuracy, set the knobs to normal operating values. Compare the knob settings to the boiler pressure readings where P7810C actions occur.

To check the control setpoint of the P7810C:

1. Note the boiler pressure by checking the boiler pressure gauge. To properly perform these tests, the boiler pressure should be near the middle of the P7810C pressure range.
2. Turn the P7810C Limit setpoint knob fully clockwise to make sure this limit does not interfere during steps 4 and 5. This setting must be returned to the proper operating position when return the system to normal operation.
3. Check the control setpoint and control differential.
4. Set the control differential knob to the center of its range.
5. Turn the control setpoint knob fully counterclockwise and make sure the P7810C control circuit is open and the green LED is off (no call for heat).
6. Read the boiler pressure gauge and add this number to the control differential setting.
7. Turn the control setpoint knob slowly clockwise and make sure the control circuit closes and the P7810C indicates a call for heat (green LED on) when the P7810C control setpoint passes through the value determined in step 6.
8. Turn the control setpoint knob slowly counterclockwise and make sure the control circuit opens and the P7810C no longer indicates a call for heat (green LED off) when the control setpoint passes through the boiler pressure gauge value.

Check the modulation setpoint and modulation range of the P7810C as follows:

1. Set the P7810C modulation range knob to the center of the range.
2. Turn the modulation setpoint knob fully clockwise and make sure the firing rate motor travels to the fully open position (boiler is firing).
3. Turn the modulation knob slowly counterclockwise and make sure the firing rate motor starts moving toward the closed position when the modulation setpoint passes through the boiler pressure gauge value. (Alternately, make sure the current starts decreasing toward 4 mA.)
4. Determine the pressure point at which minimum modulation output will occur by checking the boiler pressure gauge and subtracting the modulation range knob setting (at midpoint).
5. Turn the modulation setpoint knob slowly counterclockwise and make sure the firing rate motor continues to move to the closed position. Make sure the firing rate motor reaches the lowfire position when the modulation setpoint reaches the pressure point identified in step 4 above. (Alternately, make sure the measured current decreases gradually toward 4 mA.)

Check the limit setpoint as follows (boiler pressure required):

1. Turn the control setpoint knob clockwise until the control circuit closes. Make sure the yellow LED is flashing and the green LED is on, indicating normal operation with a call for heat.
2. Turn the limit setpoint knob slowly counterclockwise and make sure that the P7810C opens the circuit and indicates a safety lockout by alternately flashing the yellow and green LED (see LED Display section) when the limit setpoint passes through the boiler pressure gauge value.
3. Make sure that the Alarm output is energized.

Check for normal system operation as follows:

1. Set all knobs to the required operating position.
2. Press the Reset Switch to clear the safety lockout condition.

3. Start the system and observe the operation through at least one complete cycle to make sure the P7810C functions properly as described in the Operation section.

## TROUBLESHOOTING

### WARNING

**Electrical Shock Hazard.**  
**Can cause severe injury, death or property damage.**  
 Line voltage is present in the P7810C and in all controller circuits. Use extreme care when troubleshooting.

To determine control malfunctions, use checkout procedures as listed in the Checkout section.

### CAUTION

**Equipment Damage Hazard.**  
**Can cause equipment damage or improper operation.**  
 Do not put the system into service until you have satisfactorily completed all applicable tests described in this checkout section, and also all tests in the Checkout section of the applicable instructions for the primary safety control and any other tests the burner and boiler manufacturer require.

## SERVICE INFORMATION

### WARNING

**Electrical Shock Hazard.**  
**Can cause severe injury, death or property damage.**  
 1. Only qualified Flame Safeguard technicians should attempt to service Flame Safeguard controls and burners.  
 2. Line voltage is present in the electrical circuits to the P7810C PressureTrol® Controller. Open the master electrical switch before replacing the device. More than one power supply disconnect may be involved.

## Scheduled Inspection and Maintenance

### Calibration

The P7810C PressureTrol® Controller was carefully calibrated during manufacturing and does not require field calibration.

### Maintenance

Keep the cover of the P7810C PressureTrol® Controller in place at all times to protect the internal components from dust, dirt and physical damage. Routine maintenance consists of occasional inspection and removal of accumulated dirt and dust. Make sure the P7810C PressureTrol® Controller is functioning properly by performing an operation check of the entire system during routine maintenance checks.



**McDonnell & Miller**  
Installation & Maintenance  
Instructions  
MM-213(G)



**Series 750**  
**Low Water Cut-Off**  
**For Use With with Remote Sensors**

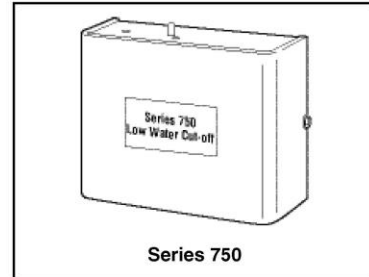

**Applications:**

- Primary conductance type control for commercial or industrial hot water boilers where remote level sensing is required.
- Secondary control for commercial or industrial steam boilers.

<b>⚠ WARNING</b>	
	<ul style="list-style-type: none"><li>• Before using product, read and understand instructions.</li><li>• Save these instructions for future reference.</li></ul>
	<ul style="list-style-type: none"><li>• All work must be performed by qualified personnel trained in the proper application, installation, and maintenance of plumbing and electrical equipment and/or systems in accordance with all applicable codes and ordinances.</li><li>• Boiler manufacturer schematics should always be followed. In the event that the boiler manufacturer's schematic does not exist, or is not available from the boiler manufacturer, refer to the schematics provided in this document.</li></ul>
	<ul style="list-style-type: none"><li>• To prevent serious burns, allow the control and surrounding equipment to cool to 80°F (27°C) and allow pressure to release to 0 psi (0 bar) before servicing.</li><li>• To prevent an electrical fire or equipment damage, electrical wiring insulation must have a rating of 167°F (75°C) if the liquid's temperature exceeds 180°F (82°C).</li></ul>
	<ul style="list-style-type: none"><li>• This low water cut-off must be installed in series with all other limit and operating controls installed on the boiler. After installation, check for proper operation of all the limit and operating controls, before leaving the site.</li><li>• When using mixed voltages, do not jumper from terminal 1 to terminal 3.</li></ul>
	<ul style="list-style-type: none"><li>• To prevent electrocution, when the electrical power is connected to the control, do not touch the terminals, or electrical wires.</li><li>• To prevent electrical shock, turn off the electrical power before making electrical connections.</li></ul>
Failure to follow this warning could cause property damage, personal injury or death.	

## SPECIFICATIONS

The Series 750 control box connected to a remote sensor provides protection against low water conditions for commercial and industrial applications. The Series 750 control box is fully CSD-1 compliant and can be used as the primary LWCO on hot water boilers and as the secondary LWCO (manual reset) on steam boilers.

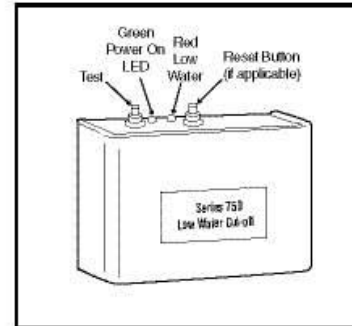

### Automatic Reset Models

Whenever water is below the level of the probe, the control will go into a low water condition. When the water level has been restored, the control will automatically return to a run condition.

### Manual Reset Models

If a low water condition occurs (water off probe), the manual reset button must be pressed once the water level is restored to a level above the probe.

### CSD-1 Code Compliance

On Manual Reset units, if the control is in a low water condition (water off probe) when there is an interruption of power, the control will remain in a low water condition when power is restored. The reset button will need to be pressed when the water level is restored to a level above the probe.

### Control Unit

#### Temperature Ratings:

Storage: -40°F to 135°F (-40°C to 57°C)

Ambient: 32°F to 135°F (0°C to 57°C)

**Humidity:** 85% (non-condensing)

**Electrical Enclosure Rating:** NEMA 1 General Purpose

### Electrical Specifications

Model	Control Voltage	Switch Contact Rating (Pilot Duty)
750-MT-24	24VAC	50VA@24VAC Or 12.5VA@120VAC
750-T-24		
750-MT-120	120VAC	
750-T-120		

**Hz:** 50/60

**Control Power Consumption:** 3 VA (max.)

**Probe Sensitivity:** 20,000 ohm

(water/glycol mixtures up to 50% concentration may be used)

## STEP 1 - Where to Install the Remote Sensors

Determine where to install the remote sensor based on the following requirements:

- The tip of the probe or extension **must be installed above the minimum safe water level**, as determined by the boiler manufacturer.
- Probes must be installed vertically if they are more than 5" (127mm) long.
- There must be a minimum 1/4" (6.4mm) clearance between the probe and any grounding surface inside the boiler.

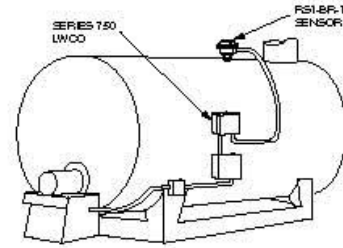
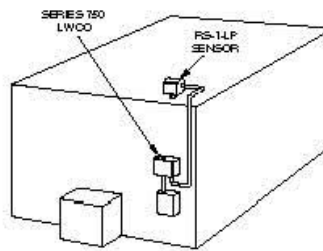

**IMPORTANT:** Remote sensors **MUST** be installed in a tapping on the boiler.

Table 2. Remote Sensors

Catalog No.	Part No.	Sensor Boiler Tapping	Sensor Housing	Sensor Pressure Rating (psig)	Sensor Temp. Rating °F
RS-1-LP	176203	3/4" NPT	NEMA 1	160 (water)/15 (steam)	250°
RS-1-BR-1*	179524	1" NPT	NEMA 4X	250 (water & steam)	406°

\* Requires probe extension (See table 3).

Table 3. Stainless Steel Probe Extensions\*

Catalog No.	Part No.	Length, Inches
RS-1/3-SS	176208	4-1/2
PS-1-SS	179530	12
G-2-SS	179156	24
G-3-SS	179157	36

\* To be used with remote sensor (RS-1-BR-1) mounted in vertical position only.

### REMOTE SENSORS

RS-1-LP  
(15 psi Steam or  
160 Psi Hot Water, Max.)

RS-1-BR-1  
(250 Psi Steam or  
Hot Water, Max.)



STAINLESS STEEL  
PROBE EXTENSION  
(4-1/2" THROUGH 36")

## STEP 2 - Installing the Remote Sensor

For the Model RS-1-BR-1 sensors, only:

- a. Cut the probe to desired length. Screw, clockwise, the threaded stainless steel probe extension (A) into the remote sensor (B). Carefully tighten the locking nut to approximately 1 ft•lb (1.7 N•m). Do not cut the clear plastic protective tube.

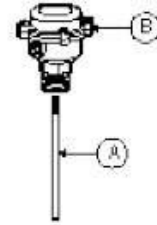

For All Remote Sensors

- b. Apply a small amount of pipe dope to the first threads (L) of the remote sensor.

**IMPORTANT:** Do not use Teflon® tape or thread sealant.

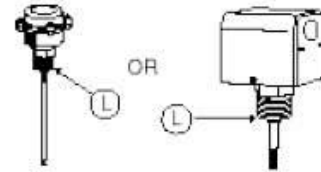

- c. Insert the remote sensor (B) into the boiler tapping (M) as determined in Step 1.

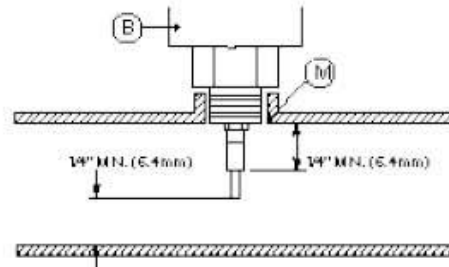

- d. Using the adjustable wrench (N), tighten the brass hex adapter (P) on the remote sensor (B) to approximately 63 ft•lb (85 N•m). DO NOT TIGHTEN BY TURNING THE SENSOR HOUSING.

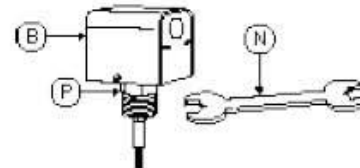

- a. Remove the sensor housing cover (Q).

1. **For Model RS-1-BR-1**, using a flathead screwdriver (R), remove the four (4) screws and separate the housing cover (Q) from the sensor (B).
2. **For Model RS-1-LP**, using a flathead screwdriver or nut driver (R), loosen the two (2) screws and separate the housing cover (Q) from the sensor (B).

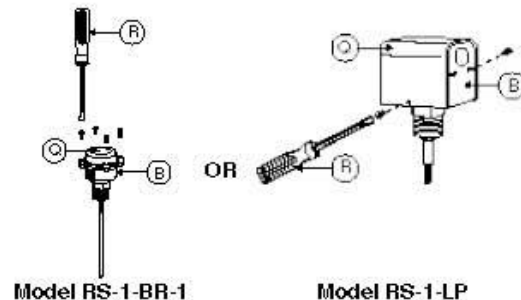

### STEP 3 - Installing the Control Box

- Mount **Control Box** in a suitable location near the boiler's main electrical panel.

NOTE
When installed as secondary LWCO on steam boilers, the boiler sight glass must be visible from the location of the control box.

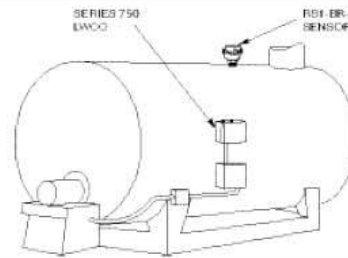

- Using the flatblade screwdriver or nut driver (C), loosen the two (2) screws (D) and remove cover (E).

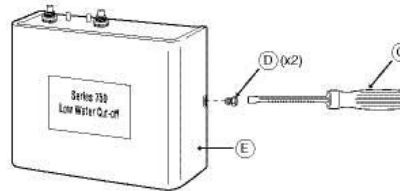

- Using the four (4) 3/16" (4.8mm) mounting holes (F), attach the control (G) to the boiler jacket, entry plate, or other suitable location.  
NOTE: Mounting hardware is not included.

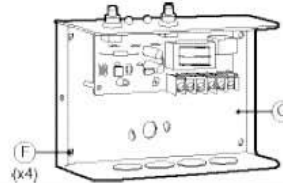

- Install an electrical conduit (H) to the conduit knockouts (J). Wire-ways should be able to accommodate the 120VAC supply circuit, the remote probe circuit, alarm feeder circuit, and burner circuit.

NOTE
Refer to and follow local codes and standards when selecting conduit and electrical fittings. Wires from Probe Housing and Control Box must be in their own conduit. If they are run in conduit with other wires, there may be interference that can affect the performance of the control.

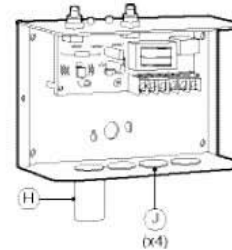

- Install electrical conduit between **Probe Housing** and **Control Box**.

NOTE
Wire must be 18 AWG stranded with glass braided silicone jacket (UL 3071) suitable for high temperature (200 °C) service.

NOTE
Refer to and follow local codes and standards when selecting conduit and electrical fittings. Wires from Probe Housing and Control Box must be in their own conduit. If they are run in conduit with other wires, there may be interference that can affect the performance of the control.

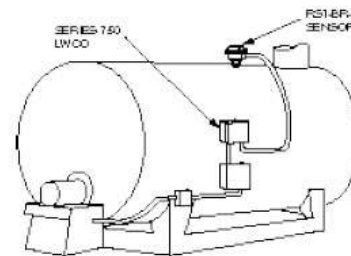

## STEP 4 - Electrical Wiring

	<b>WARNING</b>
	To prevent electrical fire or equipment damage, electrical wiring must have a rating of 167°F (75°C) if the liquid's temperature exceeds 180°F (82°C). Failure to follow this warning could cause property damage, personal injury or death.

	<b>IMPORTANT</b>
Boiler manufacturer schematics should always be followed. In the event that the boiler manufacturer's schematic does not exist, or is not available from the boiler manufacturer, refer to the schematics provided in this document.	

<b>NOTE</b>
Probe wires should be minimum 18 AWG stranded with glass braided Silicone jacket (UL 3071) suitable for high temperature (200°C) service.

<p><b>Wiring Diagram Legends</b></p> <ol style="list-style-type: none"> <li>1. Bold lines indicate action to be taken in Step shown.</li> <li>2. Dotted black lines indicate internal wiring.</li> </ol>
--

**Remote Sensor Wiring:**

- Connect wire from probe end to Terminal 'P'.
- Connect wire from remote sensor green ground screw to chassis green ground screw

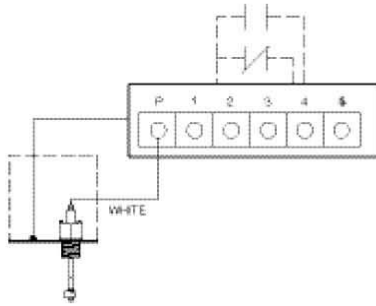

**Control Wiring: Same voltage for control and burner circuit**

- Connect hot wire to terminal 1
- Connect neutral wire to terminal 2
- Connect jumper wire from Terminal 1 to Terminal 3
- Connect wire from beginning of Burner circuit (thermostat, gas valve, limits, etc.) to terminal 5
- Connect wire from end of Burner circuit to terminal 2

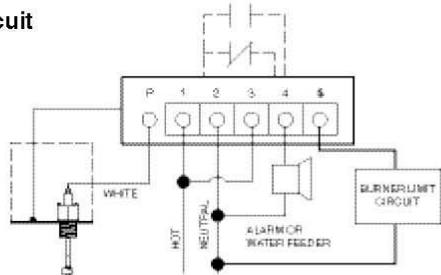

**Control Wiring: Different voltage for control and burner circuit**

- Connect hot wire to terminal 1
- Connect neutral wire to terminal 2
- Locate Boiler Burner Safety Circuit and connect wires to Terminals 3 & 5 as shown to interrupt circuit

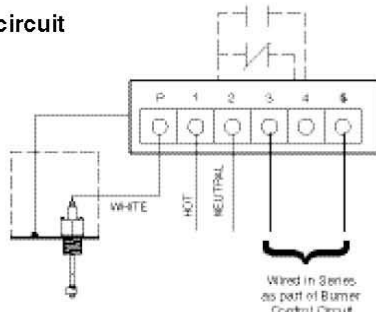



## STEP 5 - Testing and Diagnostic Procedures

### Series 750 LWCO with Green Power On LED and Red Low Water LED

#### Start-Up

**a. Before filling the system**, turn on the electric power to the boiler.

1. Upon initial power up, the Green and Red lights will flash simultaneously 4 times.
2. The Green and Red lights will turn "ON".
3. The burner will never turn "ON" during power up, if water is off the probe.

**b. Now fill the boiler with water.**

**(auto reset units only)**

1. When water touches the probe, the Green light will remain "ON".
2. The Red light will turn "OFF" and the burner will turn "ON" as long as there is water on the probe.

**(manual reset units only)**

*(When water returns to the probe, nothing will happen until the manual reset button is depressed.)*

1. After depressing manual reset button, the Green and Red lights will flash simultaneously 4 times.
2. Then the Green light will turn "ON" and the Red light will turn "OFF".
3. The burner will turn "ON" as long as there is water in the probe.

#### Manually Testing Control

**c. Slowly drain the boiler of water.**

**(both auto and manual reset units)**

1. When the water drops off the probe, the Green light will remain "ON".
2. The Red light will turn "ON" and the burner will turn "OFF", if water is off the probe.

#### Testing Control Using "Test Button"

**d. Depressing the test button with "water on probe" (auto reset units only):**

*(Must depress and hold test button to activate test cycle.)*

1. When test cycle is activated the Red and Green lights will flash simultaneously 3 times.
  2. The Red light will turn "ON".
  3. The burner will turn "OFF".
  4. The Green light will continue flashing as long as the test button is depressed.
- (Release test button, if water is still on probe.)*
5. The Green lights will stop flashing and turn "ON".
  6. Then Red light will turn "OFF".
  7. The burner will turn "ON" as long as there is water in the probe.

**e. Depressing the test button with "water on probe" (manual resets units only):**

*(Must depress and hold test button to activate test cycle.)*

1. When test cycle is activated the Red and Green lights will flash simultaneously 3 times.
  2. The Red light will turn "ON".
  3. The burner will turn "OFF".
  4. The Green light will continue flashing as long as the test button is depressed.
- (Release test button. You must depress the manual reset button to unlock the low water cut-off.)*
5. After depressing manual reset button, the Green and Red lights will flash simultaneously 4 times.
  6. Then the Green light will turn "ON" and the Red light will turn "OFF".
  7. The burner will turn "ON" as long as there is water in the probe.

**f. Depressing the test button with "water off probe" (both auto and manual reset units):**

*(Since control is in "low water" the Green light will flash and the Red light will remain "ON". The burner will remain "OFF".*

#### CSD-1 Compliance

On manual Reset units, if the control is in a low water condition (water off probe) when there is an interruption of power, the control will remain in a low water condition when power is restored. The reset button will need to be pressed when the water level is restored to a level above the probe.

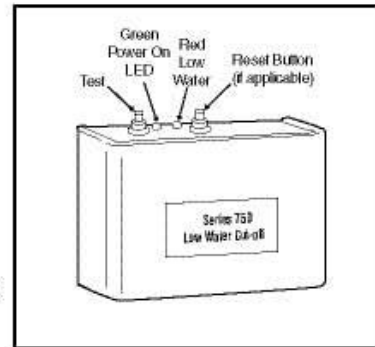



**If control fails to operate, perform the following diagnostic checks.**

1. Check to be sure the water level in the boiler is at or above the level of the probe.
2. Re-check all wiring to ensure proper connections as specified in boiler manufacturers wiring diagrams or these instructions.
3. Check to ensure that Teflon® tape has not been used on the threaded connection of the electrode to the boiler.
4. Re-check the electrical ground connection for the remote sensor and control unit.
5. Check the quality of the boiler water to ensure adequate conductance.

## MAINTENANCE

### SCHEDULE:

- **Inspect probe annually or more frequently for scale build-up and clean or replace if necessary.**  
Make certain there is no scale or build-up on the probe or it's white Teflon® insulator. Be careful not to damage the Teflon® insulator.
- **Test the low water cut-off annually or more frequently, if required by code.**

### CAUTION

**Replace Probe if:**

- Teflon® insulator is cracked or worn.
- Probe is loose.

**Failure to follow this caution could cause property damage, personal injury or death.**

- **Replace probe every 10 years.** More frequent replacement of the probe is required if it is used in locales where significant water treatment is required, or in applications with high make-up water requirements
- **Replace the low water cut-off every 15 years.**

### NOTE

**Clean probe by wiping with non-abrasive cloth and rinsing with clean water. DO NOT use sharp instruments to remove any accumulations of rust or scale.**

ITT  
8200 N. Austin Ave.  
Morton Grove, IL 60053  
tel: 847-966-3700  
fax: 847-966-9052  
www.mcdonnellmiller.com



©2010 ITT Corporation  
Printed in U.S.A. 3-10 210210

# TRIAD BOILER SYSTEMS, Inc.

## Section VII

### GENERAL MAINTENANCE



**CAUTION:** Start with a review of the warnings, cautions, notes and NBBI recommendations found in Section I of this manual.

Maintain a clean boiler room. Provide “clean” water to the boiler. Maintain a planned program of proactive preventive maintenance.



**WARNING: NEVER** “dry fire” the boiler - operate the boiler and burner without the boiler being completely filled with water.

**NEVER** operate the boiler without a functional Low Water Cut Off control.



**NEVER** operate the boiler without a functional High Pressure Limit control.



**NEVER** reset a “tripped” manual shut-off without first removing the boiler from service, determining the cause of the problem and correcting the cause.

**WARNING: NEVER** operate the boiler without an ASME approved, steam rated safety relief valve matched for both BTU/hr and pressure relief values.

Test and inspect the relief valve at least annually. Replace defective valves immediately or as required by code. See Safety Relief Valve manufacturer's tag.

**NEVER** operate a boiler if the safety relief valve has discharged. If the safety relief valve has discharged, something is wrong. Immediately remove the boiler from service and have a trained service technician investigate and correct the problem.



**Warning:** “Blow-down” – flush – the Low Water Cut Off controls at least daily during service periods. Failure to thoroughly flush the controls can render them inoperative.

If the burner continues to operate during a blow-down, the boiler needs to be removed from service and the controls inspected immediately.

**NEVER** add water to an overheated boiler. This can cause an immediate conversion of the water to steam with an explosive increase in volume. Turn OFF the burner and allow the boiler to cool slowly.

**NEVER** fire a boiler without the turbulators installed in the fire tubes.

**NEVER** fire the boiler if the firebox or tubes have excessive buildup or there appears to be signs of water leakage in the combustion chamber. .

**NEVER** bypass any of the controls on the boiler, fuel train or burner. If a control is considered defective, replace it before using the boiler/burner again.

**NEVER** fire a boiler above its rated input.

**NEVER** allow a boiler to be exposed to freezing conditions. If used outdoors, properly protect the system from the weather.

All TRIAD boilers are built to meet or exceed the Section IV ASME standard and are registered with the National Board to perform at a maximum of 15 psi (low-pressure steam) or a maximum of 150 psi (high-pressure steam). The boilers and their controls are designed only for heating water.

**NEVER** expose a boiler to thermal shock. Thermally induced stress cycling can result in metal fatigue or failure. Maintain a minimum temperature differential between boiler feed water and vessel water. **NEVER** introduce “cold” water into a hot boiler. Boiler feed water should be a nominal 160°F before entering a hot boiler. Thermal shock voids the boiler warranty.

In a steam system, good water quality and treatment are very important. The introduction of new water into a steam system also introduces oxygen (possibly with other dissolved gasses, minerals, particulates and organic material). This can cause internal corrosion, scaling and fouling material to

build up in the boiler and system. Establish a suitable boiler water treatment program to reduce oxygen, scale, sludge buildup, corrosion and to control ph.

Regularly verify that all ventilation, combustion air openings and louvers are clean and free of debris.

### OPERATORS & TRAINING

Operators should be trained in and develop a thorough familiarity of the system and its controls.

Operators should be trained in the use of fire prevention equipment.

Operators should review and become familiar with all manuals, diagrams and warnings related to the system, the boiler and the burner.

Written site procedures should be developed and be readily accessible to all operators.

A permanent logbook should be maintained in the boiler room to record maintenance work, inspections, tests and other pertinent data.

Only a qualified service technician should make burner or system adjustments and perform heating season start up.

The boiler should normally operate on its own controls once it receives the "Call For Heat" signal. If the burner should fail to light after a "Call For Heat", a system malfunction has probably occurred. A qualified service technician should determine the problem and correct it before putting the boiler back into service.

### PREVENTIVE MAINTENANCE – SUMMARY

NOTE: Read the tag attached to the Safety Relief Valve -- FOLLOW THE MANUFACTURER'S INSTRUCTIONS COVERING INSPECTION, TESTING, AND REPLACEMENT.

WARNING: Protect yourself when testing Safety Relief Valves and performing blow-down of Low Water Cut-Off valves – hot water and steam will flow from the drainpipes. If the burner does not shut-off during blow-down procedure, remove the boiler from service, determine the cause and correct it before returning this boiler to service. .

Safety relief valves should be inspected and tested at the start of each service period and monthly during the service period.

## MAINTENANCE

During the annual boiler inspection and cleaning, remove the valve and check for deposits in the valve and plumbing. If the valve has buildup, fails to operate or leaks, replace the valve only with an ASME approved steam relief valve of both the same pressure and BTU/hr rating. **NEVER** operate a boiler without a functional safety relief valve.

Under normal service conditions, replace the valve every three to five years

Blow-down valves should be inspected and tested at the beginning of each service period. Blow-downs should be performed at least daily during service period. See manufacturer's tag.

The boiler room area should be kept as clean as possible and free of all debris. The boiler room should be thoroughly washed down at least weekly to eliminate all dust and dirt, which will help extend the intervals between boiler fireside cleanings. .

### WATER

Properly treated vessel water is highly important, and critical for normal boiler service life and correct operation. Automatic feeding is highly recommended over periodic or "slug" / "shot" feeding. This is water free of excessive minerals and gases with a nominal pH of  $7.8 \pm 0.5$ . A pH reading of around 10.0 or higher can result in priming and surging, which can cause wet steam and/or flooding of the steam supply and steam header. A pH level only a single digit away from these recommendations can make a dramatic difference. This is because each increasing level of pH is ten times greater than the prior level. So for example, a pH of 8 is ten times more acidic than a pH of 9, and one hundred times more acidic that a pH of 10. Conversely, a pH of 8 is ten times more basic (alkaline) than pH of 7.

Water Items	Levels
pH	7.5 to 9.5
TDS	<2000 ppm
Hardness CaCO <sub>3</sub> (Calcium Carbonate)	<10 ppm
Alkalinity	<300 ppm
Organic Carbon	No sheen or Foam (1)
Iron	Colorless Liquid (2)
Suspended Solids	No visual turbidity (3)

(1) Organic Carbon – After a water sample sits for 10 minutes there should be no visible solids.

(2) Iron – Hold a water sample against a white background and there should be no visible yellow, red, or orange tinge.

(3) Suspended solids – Vigorously shake a water sample for 30 seconds. There should be no visible sheen or foam.

## SECTION VII

Water samples should be taken from the lower part of the boiler, not from an area higher up such as the gauge glass.

Raw makeup water (feedwater) contains dissolved oxygen, suspended solids such as dirt, minerals and organic materials that can cause corrosive failure and a buildup of scale inside the boiler. One way to lower the amount of dissolved oxygen in feedwater is use a sparge tube. This injects steam into the feedwater to increase the temperature to 180°F to remove oxygen.

Scale is a very effective insulator that will cause a loss of heat transfer efficiency and eventually tube sheet failure. Hard water results in a high amount of suspended solids. This condition is not covered under the boiler warranty.

Water that is too soft can be even more aggressive, so a minimum hardness is usually recommended. And both soft and hard water conditions can result in boiler surging, which can produce wet steam.

Too much oil present in the water will also cause foaming and surging. Other items that also are harmful to the boilers include silica, iron, chlorides, and phosphates.

#### **Following are several water treatment terminology items:**

Alkalinity – Levels of this determine the ability of acids to be neutralized in water. Alkalinities can form carbon dioxide in steam, which is the primary culprit in corrosion in condensate lines. High alkalinity also causes foaming and carryover in boilers. High levels can be from infrequent blowdowns, or an overdose of alkaline water treatment chemical.

Chlorides – The higher the levels, the more corrosive the water. These can be controlled by increasing the amount of corrosion inhibitor or changing the type of inhibitor used.

Dissolved Oxygen – High levels in the feedwater and boiler can cause pitting. It is very difficult to stop pitting once it has started, and can proceed very quickly. Preheating feedwater can help prevent this. Iron (Oxides) – Iron can start in the raw feedwater, condensate return water, or from directly in the boiler due to corrosion. It can be a major culprit in developing of scale.

Oil - Oil can get into boiler water from various sources, including high levels in a new boiler, or from the condensate. It can contribute to scale formation and cause foaming.

pH – This is a measure of the level of acid or base of water. If too low (acidic) corrosion will increase, if too high then scale can develop. It can also cause water carryover. It is very important to continuously monitor pH levels.

Phosphates – High levels can cause scale formation. It usually comes from some type of pollution in the groundwater.

Sodium Sulfite – This is used to remove dissolved oxygen from the feedwater before it gets to the boiler. It reacts with oxygen to produce sodium sulfate (versus sulfite). Feedwater at all times should have slightly more than enough sodium sulfite to consume all the dissolved oxygen. If not fed continuously, the boiler may not be protected from oxygen corrosion. This is a very important aspect of water treatment.

TDS – Total Dissolved Solids are undissolved organic matter such as dirt and silt in the water. This can cause high hardness in feedwater, and result in foaming or carryover.

**A thorough review by a qualified water treatment system specialist should be done, and their recommendations followed.**

#### **DAILY/WEEKLY PROCEDURES – Verify:**

- Boiler operation on “Call For Heat”.
- Normal burner light off.
- Pump and boiler feed solenoid operations.
- Fuel supply is not restricted. .
- Feed water temperature to a nominal 160°F.
- Water treatment and expansion tank operations.
- Damper operations.
- Combustion air supply.
- Gauge glass is clear.

#### **WEEKLY/MONTHLY PROCEDURES**

- A thorough wash down of the boiler room.
- **Check the safety relief and blow-down valves.**
- Check and lubricate all system motors.
- Check and clean any strainers.
- Check all venting and breaching.
- Review burner combustion readings.
- Verify that the air separation, water treatment and makeup/feed/condensate systems are operating per manufacturer's instructions.

## **ANNUALLY or during a lay-up period:**

Shut down the boiler by following the procedure in “REMOVING A BOILER FROM SERVICE” below in this section.

The waterside and fireside of the boiler should be inspected to determine their condition. Boilers out of service for extended periods (more than seasonal) should be properly laid-up dry. Ensure that idle boilers are protected from freezing conditions if laid-up wet.

The frequency of cleaning will depend on the effectiveness of the water treatment program, the fuel type, efficiency of the burner, characteristics of the site combustion air supply and breeching effectiveness.

A coating of 1/8" of scale on the lower tube sheet can cause a loss of 13 percent of BTU/hr transfer and may lead to tube failure from thermal shock.

Inspection of the boiler vessel should occur at least annually or whenever a 1/8 inch of scale has built up in the vessel. Initial 30 and 90-day inspections are recommended.

## **WATERSIDE CLEANING**

**SURFACE SKIMMING:** After the first several days of operations, a new boiler needs the water level surface to be skimmed. Anytime there is evidence of moisture above the water line in the gauge glass, surging (“priming”), frothing, or violent changes in the water line, or carry over into the top of the gauge glass, the boiler should be skimmed. Since this requires some plumbing and operating the boiler under controlled and monitored conditions, it is covered in the technical support section of this manual – see Section VIII.

**ANNUAL INSPECTION:** Drain and flush the vessel. Remove all inspection clean-out caps. Inspect interior surfaces for signs of corrosion or pitting. If advanced corrosion is evident, remove all supply/return lines and arrange for boiler pressure testing or replacement.

A light coating of scale is acceptable, but deposits or evidence of sludge must be cleaned and water treatment procedures set up/improved immediately. High pressure water spray should be directed at any deposits. Deposits are typically easier to remove while still warm and wet as long as the boiler has drained and cooled enough for maintenance. Chemical agents may be used, but follow the chemical agents manufacturer's instructions.

## **MAINTENANCE**

Inspect the safety relief valve.

If the boiler is not to be returned to service soon, dry the inside with forced warm air and minimize exposure to humidity and moisture.

If the boiler is to be laid-up wet, then run through at least one full cycle after filling before isolating it from the system to drive off excess oxygen. This will help limit corrosion exposure.

## **FIRESIDE CLEANING**

Fireside cleaning is critical because a 1/16” coating of soot, which is essentially unburned fuel, may present a fire hazard and can cause a 25 percent loss of efficiency of the boiler.

A qualified service technician should perform the following maintenance items:

Remove the burner, the burner adapter, the boiler jacket top, insulation disk and smoke hood. Inspect surfaces including turbulators, interior of fire tubes, and firebox for evidence of soot. Brush clean each fire tube; wipe clean each turbulator, vacuum the entire firebox of soot.

Replace turbulators that are worn or damaged or that have their lower portion burned off.

Burned-off turbulators and excessive sooting indicates problems with the fuel supply, burner settings, combustion air supply, and/or breeching.

Clean, check and adjust the burner. .

Inspect firebox refractory for cracks or deterioration. Repair with suitable refractory material if required, following the manufacturer's instructions.

Inspect all sealing gaskets and rope and replace as required.

Re-install the burner, burner adapter, smoke hood, insulation disk and jacket top

## **AFTER CLEANING**

Leak test the fuel train.

Verify the operation of all boiler mounted controls and gauges. Replace as necessary. Lubricate all mechanical equipment such as fans and pumps and verify motor rotation.

Check all plumbing for leaks or missing insulation.

## **SECTION VII**

Check all venting and breeching for leaks.

Have the water retested and the water treatment system serviced.

If required, have the boiler inspected by an authorized inspector. Local/state codes may apply.

## RESTARTING THE BOILER



**WARNING: NEVER** "dry fire" the boiler – operate the burner without the boiler completely filled with water.

Do not operate the boiler without a functional Low Water Cut Off control.

Do not operate the boiler without a functional High Pressure Limit control.

Follow the initial startup procedures as outlined in Section V above and in particular refilling the boiler with water, properly re-connecting the fuel source and properly re-connecting the electric wiring.

Follow the burner manufacturer's startup instructions.

Monitor the boiler through several complete cycles to confirm proper operation. Check burner for normal light-offs and complete shutdown

Record combustion product readings and compare with initial values. Investigate significant changes.

Return the boiler to service.

Update all maintenance information in the log book.

## REMOVING A BOILER FROM SERVICE



**WARNING:** Verify that the burner has completed its cycle and that it has turned itself OFF.

1. Turn the power switch on the burner to OFF.
2. Turn the ON/OFF switch on the boiler to OFF.
3. Turn off the control signal to the boiler (thermostat).
4. Allow the boiler to cool slowly and then relieve any residual pressure (check the

gauge and carefully open the safety relief valve) before performing maintenance.

5. Disconnect the fuel supply from the burner and the power to the boiler and all its accessories.
6. Isolate the boiler by cutting off the make-up water to the vessel and closing the gate valve to the steam header.

If the boiler has been taken out of service due to an operational problem, ensure that the necessary repairs/services have been completed before putting it back into service. If required, arrange to have the boiler inspected. Follow the initial startup procedures as outlined in Section V above.

**TRIAD Boiler Systems, Inc.**  
**Limited Standard Warranty for Hot Water and Steam Boilers**

The Manufacturer warrants the pressure vessel against leaks due to pressure vessel or coil failure under normal use and service for a period of Ten (10) full years for hot water boilers and Two (2) full years for steam boilers from date of original manufacture.

The Manufacturer warrants its other manufactured parts to be free of defects in material or workmanship under normal use and service for a period of One (1) full year from the date of original manufacture.

All original equipment manufacturer (OEM) components are only covered by their respective warranties.

The Manufacturer's obligation under this warranty shall be limited solely to repairing or replacing the vessel or part, which upon the Manufacturer's examination shall prove to be defective. The Manufacturer shall not be liable for freight, handling, installation and labor costs, or any other costs involved with the replacement of the defective components, parts, vessel, or shell/coil assembly. This warranty is contingent upon proper evidence that the installation is recorded at the factory; is consistent with Manufacturer's design and maintenance recommendations, and meets local codes. Claim notification/requests must be documented to, and accepted by, TRIAD Boiler Systems, Inc. before a claim would be validated. The Manufacturer reserves the right, at its expense, to require qualified third party inspection.

This warranty is voided if the boiler water quality, and feed water for steam boilers, is not regularly checked and properly treated as per the recommendations of Triad Boiler Systems, Inc. in the operations and maintenance manual shipped with the boiler. This warranty is voided if the vessel is subjected to heating fluids other than water; or excessive and/or untreated makeup water causing internal corrosion, scaling or fouling material buildup. This warranty is voided if the pressure vessel is exposed to excessive temperature differentials; cycling stress resulting in metal fatigue or failure; low loop return temperatures that cause condensation; operations without the spirals or turbulators in place; dry firing; defective low water cutoff or high limit temperature controls; excessive buildup in the fire tubes or breeching; or firing rates exceeding the rated input. This warranty is voided if the coil is exposed to electrochemical or chemical corrosion; electrolysis or galvanic action; water flow rates exceeding 6 feet per second; fouling of the coil; or aggressive water.

It is the owner's responsibility to operate the boiler safely and to follow procedures to ensure proper care and maintenance as per the operations and maintenance manual. Chlorines and acids in the atmosphere are damaging to steel boilers. It is the owner's responsibility to periodically test for the presence of these chemicals.

This warranty is in lieu of all other warranties expressed or implied, including but not limited to implied warranties of merchantability and fitness for a particular purpose, and of all other obligations or liabilities on the part of the Manufacturer. TRIAD Boiler Systems, Inc. neither assumes nor authorizes any other person(s) to assume for it any obligations or liability in connection with the sale of said equipment or any part thereof. This warranty will not apply to the boiler, or any part thereof, which has been subjected to any accident, negligence, misapplication, abuse or misuse. It is agreed that TRIAD shall have no liability, whether under this warranty, or in contract, tort, negligence, or otherwise, for any special, consequential, or incidental damage, including damage from water leakage. This warranty is void where prohibited and does not apply outside of the Continental United States

Model number \_\_\_\_\_

Serial Number \_\_\_\_\_

Owner \_\_\_\_\_

Date Installed \_\_\_\_\_

Installation Address \_\_\_\_\_

City and State \_\_\_\_\_

**Triad Boiler Systems, Inc.**  
1099 Atlantic Drive, Unit 2  
West Chicago, Illinois 60185  
Telephone: 630-562-2700 Fax: 630-562-2800



# TRIAD BOILER SYSTEMS, INC.

## Section VIII

### TROUBLESHOOTING



**CAUTION:** Start with a review of the OEM equipment information found in Section VI of this manual and the burner manufacturer's manual -- note all WARNINGS.



**WARNING:** BEFORE ATTEMPTING ANY ELECTRICAL CIRCUIT ANALYSIS REMOVE BOILER FROM NORMAL SERVICE AND REMOVE POWER FROM THE BOILER. Failure to use the required care and caution can result in electrical shock, injury, and extensive property damage.



**WARNING:** Make sure the burner is rendered inoperative before cutting off the waterside of a boiler -- never dry fire a boiler.

NOTE: ASME's CSD-1 requires that only listed controls be used on boilers. Rebuilt controls do not comply with this standard and are never recommended.

These suggested guidelines are for general troubleshooting only by qualified individuals such as a licensed electrician or HVAC technician with both the appropriate technical training and the necessary experience to work on powered systems. See warnings in Section I.



If you are not a professional repairperson qualified to work on HVAC equipment stop here and call for service.

#### IF BOILER WON'T FIRE:

Please follow these steps in the order presented.

##### A. CHECK POWER TO BOILER and BURNER

Check to see if the power switch on the boiler's electrical junction box is in the ON position. If not, then switch it ON! If this does not correct the problem then turn OFF the ON/OFF power switch and remove the screw on cover. Verify that service power to the boiler is present. Check the fuse(s)!

Turn ON the power.

Check to see if the power switch on the burner's panel is in the ON position. If not, then switch it ON

##### B. IF - NO "CALL FOR HEAT" - CHECK THE R845A CONTROL CENTER

Terminals 1 & 2 should have line voltage present. If there is no power to the control, check the source of the neutral and line voltage. Correct the problem.

If there is power to the Control Center, then check the "Call For Heat" terminals -T-T for 24VAC. If T-T are without power, possibly this control is defective.

If there is low voltage power at T-T, then check the circuit between T-T in the Control Center and the actuating device that completes this connection - a thermostat; a control panel; a temperature control; or an on/off switch. Correct the problem.

**\*\* For boilers with L404 Pressuretrol Controls,** check for line voltage at terminals 4 and 2. The "Call For Heat" light should be "ON". If not, it may be burned out. If not possibly the jumper between terminals 1 and 3 is not properly connected. Verify that terminals 5 and 6 are "closed" and "dry". If not, possibly this control is defective.

**\*\* For boilers with an R7810C Pressuretrol Control,** you must check the "Call For Heat" light on the control itself. There is not a "Call For Heat" light on the Control Center in this case. Check terminal 6 for line voltage. If none, check terminal 5 for line voltage. If line voltage is present on terminal 5 but not 6, the relay connecting the load between terminals 5 and 6 is not functioning properly. The Control Center may be defective. If terminal 5 has no voltage, there is a power problem further upstream of the Control Center.

If the Control Center is operating correctly, proceed to the next step. .

### **C. IF - NO “CALL FOR HEAT” – WITH AN P7810C PRESSURETROL**

The R7810C control requires line voltage power to operate. Power is provided by a limit circuit that connects through both low water cut off controls.

#### **FIRST - CHECK FOR LOW WATER CONDITION**

Check the water level in the gauge glass mounted on the front of the boiler. If the water level appears to be correct, verify that both low water controls are functioning correctly.

If the manual reset circuit of the 67M LWCO has “tripped” this indicates a serious Low Water condition for the boiler. Immediately take the boiler out of service until the cause of the problem is identified and corrected

#### **CHECK FOR A HIGH PRESSURE CONDITION**

Check the pressure gauge mounted on the front of the boiler. If the pressure gauge reading appears to be correct, verify that the P7810C Pressuretrol is operating correctly.

The P7810C is a dual function control that provides the Operating Pressure On/Off control and the Safety Pressure High Limit control - each with separate electronic sensors

Verify that the vessel pressure has not exceeded the Safety Pressure High Limit of the P7810C control. If the manual reset circuit of the P7810C has “tripped” this indicates a serious High Pressure condition for the boiler. Immediately take the boiler out of service until the cause of the problem is identified and corrected

The Operating Pressure side of the control should have stopped the boiler operation before the High limit side of the control with manual reset was tripped. Verify that the set point for the Operating Pressure limit is set lower than the Safety Pressure High Limit. If so, then possibly the Operating Pressure electronic sensor may be defective

If the vessel steam pressure is not above the operating high limit **and** a low water condition does not exist, there may be a problem with the P7810C control.

To diagnose this control, refer to the OEM Components section of this manual for this specific control. Refer to the heading “checkout” for trouble shooting assistance.

### **D. THERE IS A “CALL FOR HEAT” BUT THE BURNER WON’T FIRE**

If the vessel steam pressure is not above the operating pressure limit **and** a low water condition does not exist **and** there is no service power problems:

#### **CHECK THE FUEL**

There could be a fuel sufficiency problem. Ensure that there are no interruptions in the burner fuel source such as low gas pressure, inadequate gallons per hour of #2 oil, etc. Resolve as necessary.

### **E. THERE IS A “CALL FOR HEAT” BUT THE BURNER WON’T FIRE (L404 CONTROLS):**

#### **FIRST - CHECK FOR LOW WATER CONDITION**

Check the water level in the gauge glass mounted on the front of the boiler. If the water level appears to be correct, verify that both low water controls are functioning correctly.

If the manual reset circuit of the 67M LWCO has “tripped” this indicates a serious Low Water condition for the boiler. Immediately take the boiler out of service until the cause of the problem is identified and corrected

#### **CHECK FOR A HIGH PRESSURE CONDITION**

Check the pressure gauge mounted on the front of the boiler. If the pressure gauge reading appears to be correct, verify that the L404 Pressuretrols are operating correctly.

Verify that the vessel pressure has not exceeded the Safety Pressure High Limit of the L4079B1033 control. If the pressure exceeds this limit setting and has tripped the manual reset, do not reset the control but immediately take the boiler out of service until the cause of the problem is identified and corrected.

The L404F1060 control should have stopped the boiler operation before the L4079B1033 – manual reset was tripped. Verify that the set point for the Operating Pressure limit is set lower than the Safety Pressure High Limit. If so, the L404F1060 control may be defective and should be replaced.

## TROUBLESHOOTING THE CONTROLS

If you have reached this point in your troubleshooting, then probably one of the controls on the boiler has failed. Refer to the wiring diagrams in Section II and the OEM Component Product Data information in section VI for specifics about testing each control.

**LWCO - 150BMD** - test for line voltage to terminal 2 and neutral. If there is power here, then check for continuity in the burner control limit circuit (gray wires) at each point. This circuit must be "on" in order for the burner to fire.

**750-MT-120** – check to be sure that the water level in the boiler is at or above the level of the probe. Re-check all wiring to ensure proper connections. Check to ensure Teflon tape was not used on the threaded connections to the boiler. Check the quality of the boiler water to ensure adequate conductance and inspect the probe to ensure it isn't loose or dirty.

**67M, L404F1060, L4079B1033** - these controls are switches only and do not require any power. If the circuit is not complete through them, then one of these controls may be malfunctioning or defective.

The boiler should not be put back into service until the problem has been identified and corrected.

If the functions of the all the controls have been verified as working properly, then check the burner for the following items:

- power switch is ON
- power light is ON
- that there is line voltage to terminals 1-2 in the control panel
- that the circuit to terminals 3-4 in the control panel is complete

If all of the controls seem to be operating properly and there is power to the burner and the burner control circuit (gray wire system), then there is probably a malfunction with the burner itself. Consult the manufacturer's burner manual for assistance.

### BOILER "SHORT CYCLING:

Modular boilers are designed to provide a balanced response to the existing heat load. At some point in any cycle, the load will be matched or exceeded by the boiler(s) response. It is normal for burners under such situations to shut down temporarily and cycle on the limit controls, similar to a household

furnace.

Excessive cycling is usually indicative of a primary circulation system that is unable to carry away the BTU/hr output of the boilers. The causes can range from improperly adjusted controls to sensor location. Excessive cycling will inevitably occur if the boiler output has been oversized. Interconnection lengths between primary and secondary loops should be kept to a minimum so that loops can act as independent circuits.

Staging works best with boilers of approximately the same size. In the event that major differences in size exist, adjustments to cycle length times, and staging "null" (boiler stages that do not have boilers) positions can sometimes help. Contact the system design engineer.

## OVERHEATING



**WARNING:** boilers heat water under pressure. When water is heated above its boiling point it can flash to steam if the pressure is removed -- maintain 2 psig minimum.

Should the manual high pressure limit control, low water cutoff, or safety relief valve activate, the boiler should immediately be removed from service. It is very important that the cause of the situation be identified as soon as possible and corrective actions be taken immediately.

Several malfunctions must usually occur before the safety relief valve is triggered. Should a boiler overheat, the response procedures should optimize the safety to people, and of the boiler and building. A readily accessible power disconnect and fuel cut off valve are recommended.

When a boiler has a severe pressure or over-heating condition causing large volumes of water, or any amount of steam, to blow out the pressure relief valve, DO NOT assume the operating and safety controls have control of the boiler.

The response to a severely over heating boiler should be to shut off the power and fuel supply and allow the boiler to cool slowly. **NEVER** introduce cold water into an overheated boiler. Adding water to an overheated boiler can produce explosive expansion as the water converts to steam.

The boiler should be thoroughly inspected for damage. Once the situation is corrected it should be restarted by a qualified technician. Its operation

must be fully monitored to confirm that the problem has been corrected before the boiler is returned to normal service.

## **BURNERS**

**WARNING: Review the burner manufacturer's instruction manual for specific warnings and for technical and service information.**

TRIAD boilers and burners are matched for optimum performance. Difficulty in setting the burner or in achieving smooth operation is usually indicative of a site problem - particularly if affecting more than one unit. Contact the system design engineer. Then, begin by checking the combustion air and breeching.

## **BOILER RUMBLES**

Venting and breeching have very significant effects on boiler and burner operations. Check draft with a gauge. Draft should be between  $-.01''$  to  $-.05''$  WC when operating. A barometric damper might have to be installed to correct this.

Check that the fuel supply system is within the burner manufacturer's specification. Also check for proper combustion airflow, faulty breeching and loose venting. It may be worthwhile to extend the distances between the gas train components: regulators and controls. This lengthening allows a longer run that may help dampen supply pressure fluctuations. Condensation in the venting suggests a burner adjustment, combustion air, or breeching problem.

## **BOILER IS SURGING**

Check these items:

Too high pH (too much water softener) or too many dissolved solids (TDS), or some other water component – so have the water tested by a treatment professional.

Too much cleaning solvent in the boiler – clean the vessel with washing soda.

Too much water treatment compound in the system – flush the system and dump the return tank and have the water tested.

Steam traps are blowing through – check the traps to see if they are clean or need replacing. A symptom of this is if live steam is coming back into the boiler room in the condensate return lines.

Boiler might be undersized, or if it is a multiple boiler installation, the controller might be having one boiler come on first to try and meet pressure, then another boiler etc. Instead, have all boilers come on at once, in low fire, and gradually bring them all up to full fire if needed, than drop ones off as required. Burner might be over firing, thus over firing the boiler. Check gas pressure and all burner settings.

The stack pressure may be too low of a negative, below  $-0.05''$ wc, thus “pulling” the burner flame up into the tubes, effectively over firing the boiler.

## **BOILER IS FLOODING**

Pump may not be shutting off due to dirty probes or a failed relay. A vacuum may be occurring when the boiler turns off. As the boiler cools it pulls water away from the system piping. Add a check valve that will close under pressure but opens under a vacuum.

Check to see if the installation is a gravity return system with motorized zone valves. When a zone valve closes and the boiler is under pressure, water will back into the return line of the closed zone which will then bring on the automatic water feeder. So the next time the valve opens the condensate returns from the system and floods the boiler. Consider installing quarter-inch bleed lines around the tops of the zone valves to let through enough pressure to keep the water from backing out of the boiler, but won't allow enough steam by to overheat the zone.

## **CONDENSATE SLOW TO RETURN TO BOILER/LOW WATER CONDITIONS OCCUR**

The slow return of condensate can be caused by an old system with piping issues. But an important question to ask – was the old system a Vacuum System that was turned into a gravity return system? This can cause problems – many things can come into play - one of which is the piping diameter will be smaller than normal, hence the reason for vacuum systems. A vacuum pump was used to pull the condensate back to the boiler room, allowing the use of smaller diameter piping, saving money. But if it has been turned into a gravity return system, the condensate will take much longer to return because it takes longer for the water to build up to the point that gravity can return to it the boiler room. This can cause low water conditions, and then flooding when condensate finally rushes back. Make sure you consult a steam engineer to assist.

## **PUMP RUNS BUT WATER NOT ENTERING BOILER**

Possible Vapor Lock – let system cool down and check steam traps, make sure return lines not insulated. Check return tank temperature, if it is above 180 degrees then vapor lock of pump will occur. Inspect the check valves and clean or replace if needed.

## **BOILER LEAKS**



**WARNING:** if the pressure vessel should develop a leak, only an ASME certified shop should make repairs. Only a qualified individual such as a licensed plumber or HVAC technician should service plumbing.

In the event that water is found around a boiler, a thorough investigation is warranted. There are typically two sources of leaks: fitting leaks and pressure vessel failure. .

Fitting leaks are typically evidenced by released steam or water accumulation around the outer perimeter of the vessel below the jacket. Because it can be difficult to determine which fitting is leaking, removal of the jacket may be required.

## **FITTING REPAIR**

After removing the boiler from service, do not simply try to tighten the fitting. Instead, remove the fitting; thoroughly clean the threads; apply new sealant (pipe dope) and re-tighten the connection. This also is the typical procedure required for a control replacement. Welded joints that develop a leak will need to be drained and re-welded.

## **PRESSURE VESSEL REPAIR**

In the rare instance of a leak of the pressure vessel such as a crack in the material or a failed weld, only an NBBI registered "R" (repair) stamp technician should attempt to repair the shell. The repaired shell must be pressure checked and inspected before the boiler is returned to service. Local and state code may also apply.

Any such repairs must only be made according to the ASME Code and within the requirements of the NBBI as authorized and approved by a commissioned inspector.

The inspector must pre-approve the method for repair and the materials to be used and establish the

inspection stages before repair work begins

A leak involving the fire tubes is usually the result of thermal shock that may have been caused through the introduction of water at an excessive temperature differential, or as the result of the accumulation of scale or sludge from untreated water.

Such damage is not covered under the warranty.

It is possible to re-expand the tubes in place, but this should only be attempted by a NBBI registered "R" (repair) stamp technician. The repaired shell must be pressure checked and reinspected before the boiler is returned to service. Welding of the tubes to the tube sheet is not acceptable.

Problems with leaks, etc. will continue to develop unless the cause of the initial problem is identified and permanently corrected.

**TRIAD Boiler Systems, Inc. – Steam Systems Check Sheet (Daily check of gauge glass and blow-down recommended)**

<b>Site/System:</b>		<b>Boiler Model:</b>		<b>Date:</b> - to -	
<b>Week 1:</b>		<b>Week 3:</b>		<b>Monthly:</b>	
	Boiler operation.		Boiler operation.		Boiler operation.
	Normal burner light-off.		Normal burner light-off.		Normal burner light-off.
	Pump & makeup solenoid.		Pump & makeup solenoid.		Pump & makeup solenoid.
	Check the fuel supply.		Check the fuel supply.		Check the fuel supply.
	Feed water and temperature.		Feed water and temperature.		Feed water and temperature.
	Water treatment system.		Water treatment system.		Water treatment system.
	Damper operations.		Damper operations.		Damper operations.
	Combustion air supply.		Combustion air supply.		Combustion air supply.
	Visual check of gauge glass.		Visual check of gauge glass.		Visual check of gauge glass.
	Perform manual blow-down		Perform manual blow-down		Perform manual blow-down
	Check:		Check:		Wash down boiler room.
<b>Week 2:</b>		<b>Week 4:</b>			
	Boiler operation.		Boiler operation.		Check (lubricate) all motors and pumps.
	Normal burner light-off.		Normal burner light-off.		Check and lever test safety relief valve.
	Pump & makeup solenoid.		Pump & makeup solenoid.		Check and clean strainers.
	Check the fuel supply.		Check the fuel supply.		Check all venting and breeching.
	Feed water and temperature.		Feed water and temperature.		Check burner combustion readings.
	Water treatment system.		Water treatment system.		Check water treatment system.
	Damper operations.		Damper operations.		Check condensate return system.
	Combustion air supply.		Combustion air supply.		Check:
	Visual check of gauge glass.		Visual check of gauge glass.		Check:
	Perform manual blow-down		Perform manual blow-down		Check:
	Check:		Check:		Check:

## IMPORTANT THINGS TO REMEMBER:

Follow the near boiler piping suggestions.

The steam header **MUST** be at least 24” above the boiler.

Connection to the supply header should be through the top of the header.

Do not alter the steam tap at the rear of the boiler.

Skim the surface multiple times before placing boiler into normal service.

Skim the surface whenever there is surging, priming or carryover into the gauge glass.

Blow-down the LWCO’s daily – which helps eliminate solids buildup.

Use proper water treatment – too much or too little can be harmful.

Avoid sudden or surge loads due to quick opening steam valves.

Avoid consistent boiler overloading – balance the staging of multiple boilers.

## AND REMEMBER TO:

- A. Follow the recommendations on preventive maintenance.
- B. Keep a clean boiler room.
- C. Low pressure steam travels **FASTER** than high pressure steam.
- D. Operators: Review the operating manual at least **ANNUALLY!**